

LIMON in Taiwan

Add: No. 409, Section 3, Meigao Road, Xinwu District, Taoyuan City, Taiwan.
Tel / :02-82853888

LIMON in P.R. China

Add: Floor 15 Building 5, Zone A, R&D Park, NO.587
Juxian Road, Hi-tech Zone, Ningbo, Zhejiang, China/
Tel:0086-0574-87515352

LIMON in Singapore

Add / :No.1 Kaki Bukit Avenue 3 (KB-1)#06-12
Singapore 416087
Tel / :0065 6286 7707

LIMON in Japan

Add:ROOM 205,GRANDEUR IMAZATO BLDG.-
NO.1-4,4-CHOME,IMAZATO,NAGAOKAKYO-CITY,617-0814,-
KYOTO,JAPAN Tel:0081-759590221

LIMON in India

Add-11:303-308, Krishna Bhuvan Annex, 22-B,
Govandi Station Road, Deonar, Mumbai - 400088
Maharashtra INDIA
Tel:0091-22-61464444 / 61464445

Add-22:D-12 LAJPAT NAGAR-3,2ND FLOOR,NEW
DELHI-110024 INDIA
Tel:0091 11 23951438

LIMON in Germany

Add:Stattmannstr. 23 D-72644 Oberboihingen
Tel:0049 7022 2629384

LIMON in Hungary

Add:1194Budapest, Hofherr Albert u. 38/B,HUN-
GARY
Tel:0036 1/455-2079

LIMON in Brasil

Add :AV. MARECHAL RONDON, 2122,CAMPINAS
-SP,BRASIL
Tel:0055 19 32 434316

LIMON in Turkey

Add:Esensehir mahallesi, kurkculer caddesi,Eryil-
maz sokak no 31Dudullu-ümraniye-Istanbul-turkey
Tel:0090 216 527 30 30

LIMON in Israel

Add:32 Amal st Petach-Tikva 49513 Israel
Tel:00972 3 9288888



LinkedIn



Website

LIMON AUTO TECH CO., LTD.

www.limonrobot.com

LIMON
PRECISION&SPEED

LIMON[®]
PRECISION&SPEED

LIMON AUTO TECH CO., LTD.

LINEAR PRECISION / LINEAR SPEED

LINEAR MOTION

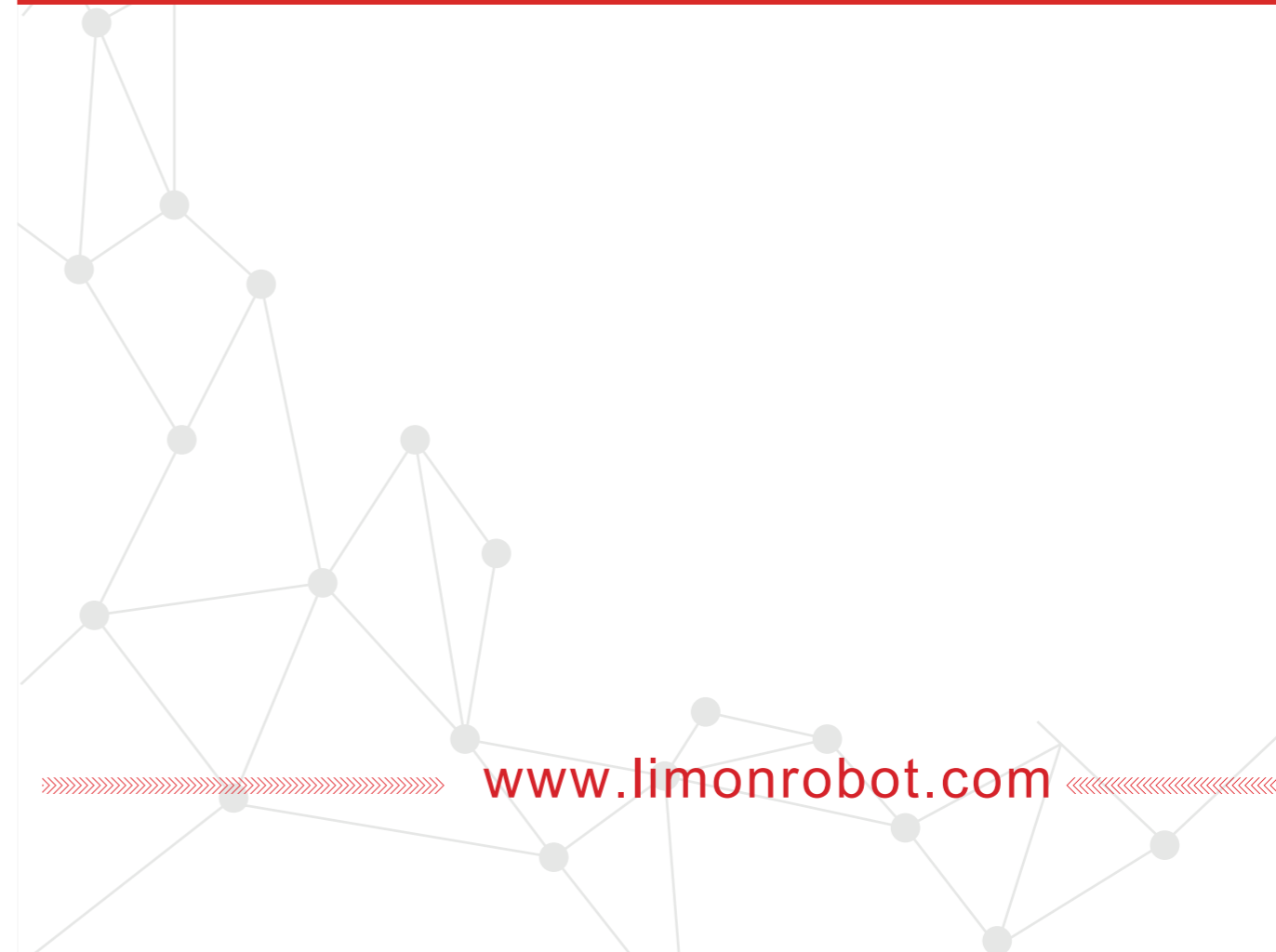

www.limonrobot.com

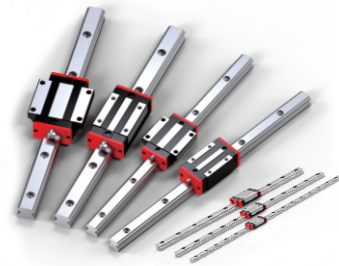

LIMON Linear Guideways:
H/E/QH/QE/R/M Series



LIMON Ball Screw:
SFA/SFS/DFS/SFU...Series



LIMON Support:
BK/BF/EK/EF... Series



LIMON Linear Bushing:
LM/LME/LML/LMEL... Series

Our Company:

LIMON was founded in 2002. We concentrate on customizing automation products and providing professional solutions for our global customers. Our company mainly focus on linear guideway, ball screw, linear unit, hollow rotary actuator, linear motor and other linear motion components, all of which have been widely used in major industrial fields like LCD panel industry, electronic industry, photovoltaic industry, automation industry, auto industry and so on.

Ever since our establishment, we have been concentrating and innovating in the automation and related industries. At present, we have set up offices in many cities in China to quickly respond to customer needs. Up to now, our business has covered more than 30 countries/regions around the world and competes with major international famous brands. Every year, we participate in more than 10 large-scale global exhibitions to keep abreast of the latest trends of the industry, providing more than 1400 solutions for customers. We sincerely pursue customized services to achieve a win-win situation with customers.

Corporate philosophy:

Mission: To be the leader of intelligence manufacturer and concentrate to improve automation industry in the region .

Vision: To be the best partners in the global automation industry.

Corporate Values: Efficiency, Concentration, Innovation ,Partnership.

Linear Guideways

- 1 General Information1
- 1-1 Advantages and Features of Linear Guideways1
- 1-2 Selecting Linear Guideways2
- 1-3 Basic Load Ratings of Linear Guideways3
- 1-4 Mounting Configurations4
- 1-5 Mounting Procedures5
- 2 LIMON Linear Guideways Classification.....9
- 2-1 H Series- Heavy Load Ball Type Linear Guideway10
- 2-2 E Series - Low Profile Ball Type Linear Guideway28
- 2-3 QH Series - Quiet Linear Guideway45
- 2-4 QE Series - Low Profile Quiet Linear Guideway58
- 2-5 R Series - High Rigidity Roller Type Linear Guideway68
- 2-6 M Series - Miniature Type Linear Guideway81

Ball Screw

- 1 General Information.....87
- 1-1 Features of LIMON Ball Screw87
- 1-2 Ball Screw Selection Procedure88
- 1-3 Selection of Nut89
- 1-4 Nut Design89
- 1-5 Accuracy91
- 1-6 Screw Shaft Design93
- 1-7 Positioning Accuracy93
- 1-8 Cautions About Use of Ball Screw.....96
- 1-9 Lubrication96
- 1-10 Dust Proof/Prevention97
- 1-11 Offset Load97
- 1-12 Assembling the Ball Screw98
- 1-13 Nominal Model Code of LIMON Ball Screw99
- 2 LIMON Ball Screw Classification102
- 2-1 SFA Series102
- 2-2 SFS Series103
- 2-3 SFNU Series104
- 2-4 DFNU Series105
- 2-5 OFNU Series106
- 2-6 SFK Series107
- 2-7 SFY Series108
- 2-8 SFNI Series109
- 2-9 OFNI Series110

Support

- 1 LIMON Support Classification.....111
- 1-1 BK/BF Series112
- 1-2 EK/EF Series113
- 1-3 FK/FF Series114
- 1-4 AK/AF Series115
- 1-5 Recommended Ball Screw End Machining Size117
- 1-6 WBK High Load Support118
- 1-7 DSG Ball Screw Nut Support121

Linear Bushing

- 1 General Information122
- 2 Linear Motion Ball Bearing128
- 2-1 KH Series128
- 2-2 LM Series129
- 2-3 LME Series131
- 2-4 LML Series132
- 2-5 LMEL Series134
- 3 Flanged Linear Motion Ball Bearing135
- 3-1 LMF/K/H Series135
- 3-2 LMEF/K/H Series137
- 3-3 LMF/K/H_L Series139
- 3-4 LMEF/K_L Series141
- 3-5 LMF/K/HP Series143
- 3-6 LMF/K/HP_L Series145
- 3-7 LMF/KC Series147
- 3-8 LMHC Series148
- 4 Slide Unit149
- 4-1 SC Series149
- 4-2 TBR Series152
- 4-3 SME Series153
- 4-4 KBA Series155
- 4-5 KBE Series158
- 5 Shaft Support159
- 5-1 SK Series.....159
- 5-2 SHF Series160

Preface

A linear guideway allows a type of linear motion that utilizes rolling elements such as balls or rollers. By using recirculating rolling elements between the rail and the block, a linear guideway can achieve high precision linear motion. Compared to a traditional slide, the coefficient of friction for a linear guideway is only 1/50. Because of the restraint effect between the rails and the blocks, linear guideways can take up loads in both the up/down and the left/right directions. With these features, linear guideways can greatly enhance moving accuracy, especially, when accompanied with precise ball screws.

1. General Information

1-1 Advantages and Features of Linear Guideways

(1) High positional accuracy

When a load is driven by a linear motion guideway, the frictional contact between the load and the bed desk is rolling contact. The coefficient of friction is only 1/50 of traditional contact, and the difference between the dynamic and the static coefficient of friction is small. Therefore, there would be no slippage while the load is moving.

(2) Long life with high motion accuracy

With a traditional slide, errors in accuracy are caused by the counter flow of the oil film. Insufficient lubrication causes wear between the contact surfaces, which become increasingly inaccurate. In contrast, rolling contact has little wear; therefore, machines can achieve a long life with highly accurate motion.

(3) High speed motion is possible with a low driving force

Because linear guideways have little friction resistance, only a small driving force is needed to move a load. This results in greater power savings, especially in the moving parts of a system. This is especially true for the reciprocating parts.

(4) Equal loading capacity in all directions

With this special design, these linear guideways can take loads in either the vertical or horizontal directions. Conventional linear slides can only take small loads in the direction parallel to the contact surface. They are also more likely to become inaccurate when they are subjected to these loads.

(5) Easy installation

Installing a linear guideway is fairly easy. Grinding or milling the machine surface, following the recommended installation procedure, and tightening the bolts to their specified torque can achieve highly accurate linear motion.

(6) Easy lubrication

With a traditional sliding system, insufficient lubrication causes wear on the contact surfaces. Also, it can be quite difficult to supply sufficient lubrication to the contact surfaces because finding an appropriate lubrication point is not very easy. With a linear motion guideway, grease can be easily supplied through the grease nipple on the linear guideway block. It is also possible to utilize a centralized oil lubrication system by piping the lubrication oil to the piping joint.

(7) Interchangeability

Compared with traditional boxways or v-groove slides, linear guideways can be easily replaced should any damage occur. For high precision grades consider ordering a matched, non-interchangeable, assembly of a block and rail.

1-2 Selecting Linear Guideways

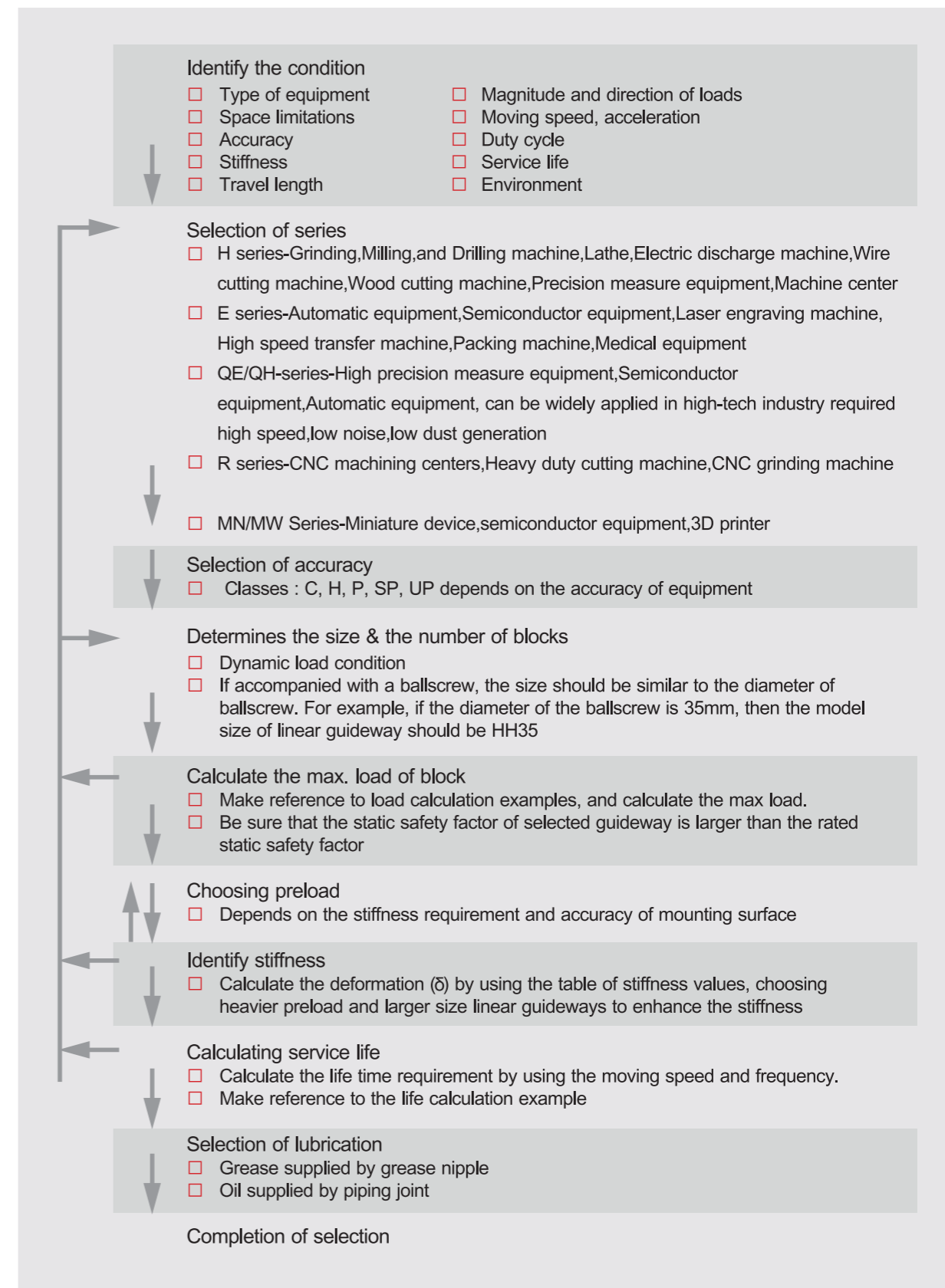

1-3 Basic Load Ratings of Linear Guideways

1-3-1 Basic Static Load

(1) Static load rating (C₀)

Localized permanent deformation will be caused between the raceway surface and the rolling elements when a linear guideway is subjected to an excessively large load or an impact load while either at rest or in motion. If the amount of this permanent deformation exceeds a certain limit, it becomes an obstacle to the smooth operation of the linear guideway. Generally, the definition of the basic static load rating is a static load of constant magnitude and direction resulting in a total permanent deformation of 0.0001 times the diameter of the rolling element and the raceway at the contact point subjected to the largest stress. The value is described in the dimension tables for each linear guideway. A designer can select a suitable linear guideway by referring to these tables. The maximum static load applied to a linear guideway must not exceed the basic static load rating.

(2) Static permissible moment (M₀)

The static permissible moment refers to a moment in a given direction and magnitude when the largest stress of the rolling elements in an applied system equals the stress induced by the Static Load Rating. The static permissible moment in linear motion systems is defined for three directions: M_R, M_P and M_Y.

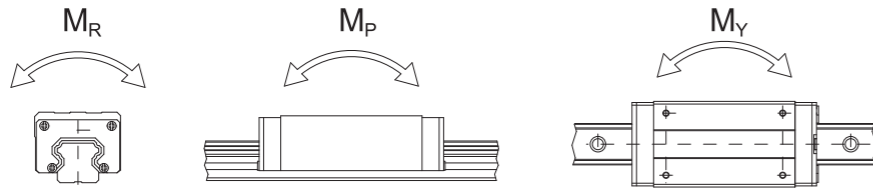

(3) Static safety factor

This condition applies when the guideway system is static or under low speed motion. The static safety factor, which depends on environmental and operating conditions, must be taken into consideration. A larger safety factor is especially important for guideways subject to impact loads (See Table 1-1). The static load can be obtained by using Eq. 1.1

Table 1-1 Static Safety Factor

Load Condition	f _{SL} , f _{SM} (Min.)
Normal Load	1.0~3.0
With impacts/vibrations	3.0~5.0

$$f_{SL} = \frac{C_0}{P} \text{ or } f_{SM} = \frac{M_0}{M} \quad \text{Eq.1.1}$$

- f_{SL} : Static safety factor for simple load
- f_{SM} : Static safety factor for moment
- C₀ : Static load rating (kN)
- M₀ : Static permissible moment (kN · mm)
- P : Calculated working load (kN)
- M : Calculated applying moment (kN · mm)

1-3-2 Basic Dynamic Load

(1) Dynamic load rating (C)

The basic dynamic load rating is an important factor used for calculation of service life of linear guideway. It is defined as the maximum load when the load that does not change in direction or magnitude and results in a nominal life of 50km of operation for a ball type linear guideway and 100km for a roller type linear guideway. The values for the basic dynamic load rating of each guideway are shown in dimension tables. They can be used to predict the service life for a selected linear guideway.

1-4 Mounting Conigurations

Linear guideways have equal load ratings in the radial, reverse radial and lateral directions. The application depends on the machine requirements and load directions. Typical layouts for linear guideways are shown below:

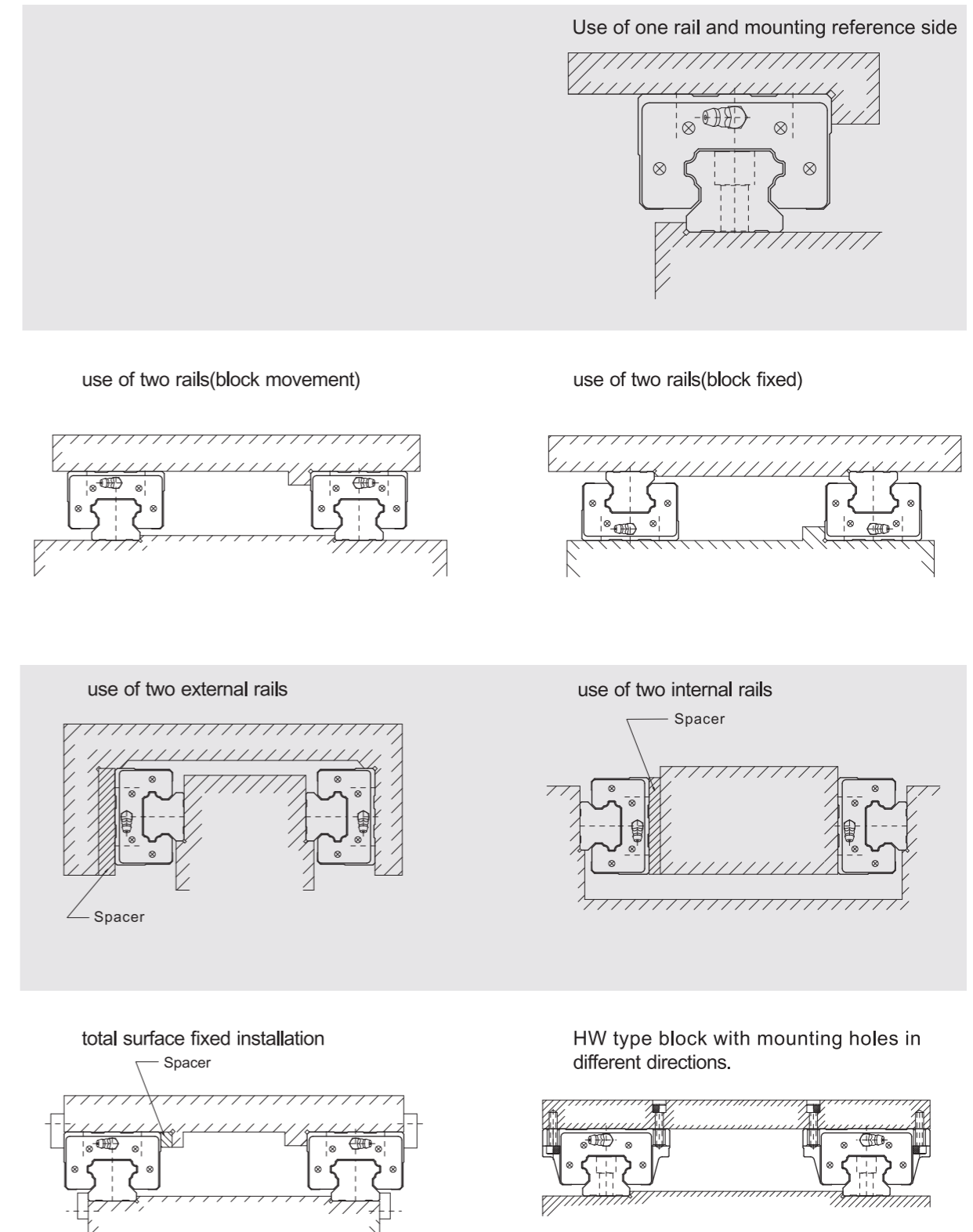

1-5 Mounting Procedures

Three installation methods are recommended based on the required running accuracy and the degree of impacts and vibrations.

1-5-1 Master and Subsidiary Guide

For non-interchangeable type Linear Guideways, there are some differences between the master guide and subsidiary guide. The accuracy of the master guide's datum plane is better than the subsidiary's and it can be a reference side for installation. There is a mark "MA" printed on the rail, as shown in the figure below.



1-5-2 Installation to Achieve High Accuracy and Rigidity

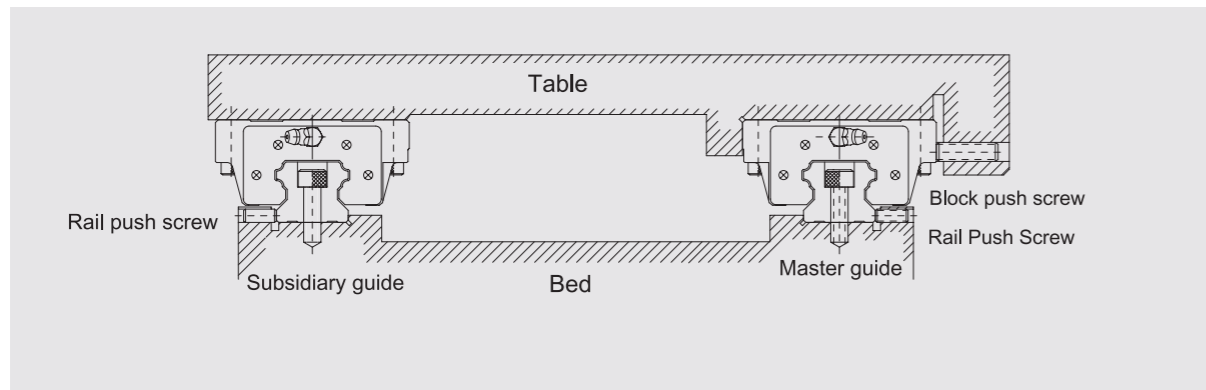

(1) Mounting methods

It is possible that the rails and the blocks will be displaced when the machine is subjected to vibrations and impacts. To eliminate these difficulties and achieve high running accuracy, the following four methods are recommended for fixing.

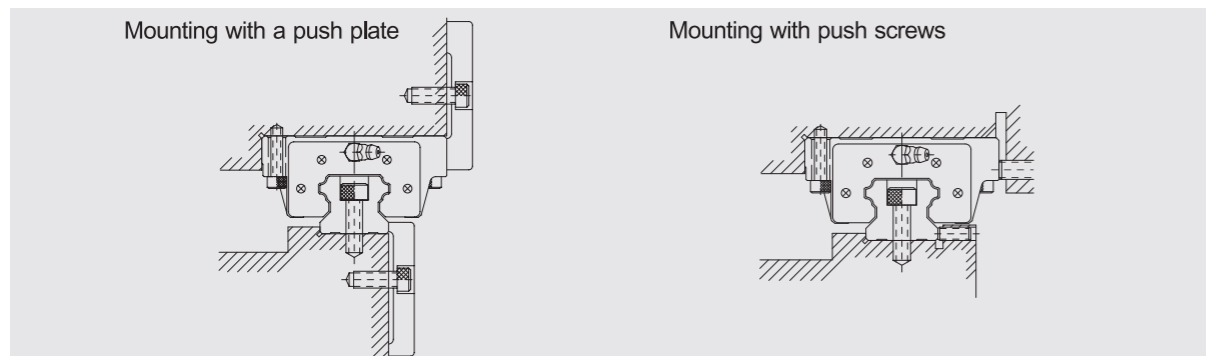

Mounting with taper gib

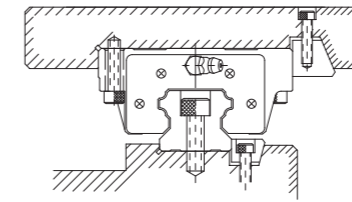

Mounting with needle roller

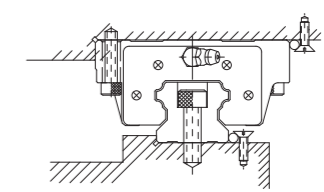

(2) Procedure of rail installation

- 1 Before starting, remove all dirt from the mounting surface of the machine.
- 2 Place the linear guideway gently on the bed. Bring the guideway into close contact with the datum plane of the bed.
- 3 Check for correct thread engagement when inserting a bolt into the mounting hole while the rail is being placed on the mounting surface of the bed.
- 4 Tighten the push screws sequentially to ensure close contact between the rail and the side datum plane.

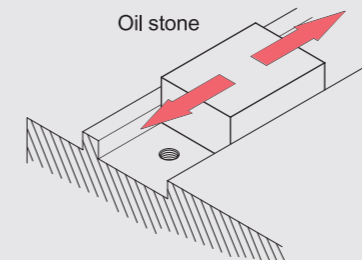

- 5 Tighten the mounting bolts with a torque wrench to the specified torque.
- 6 Install the remaining linear guideway in the same way.

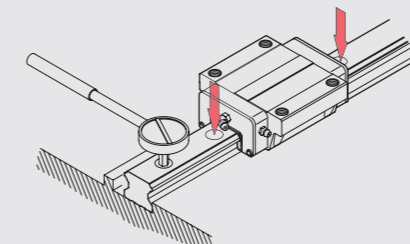
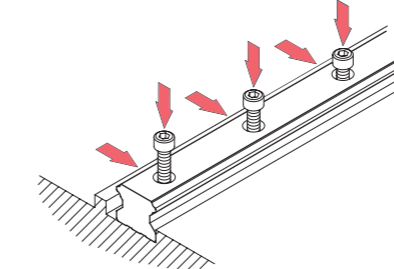

(3) Procedure of block installation

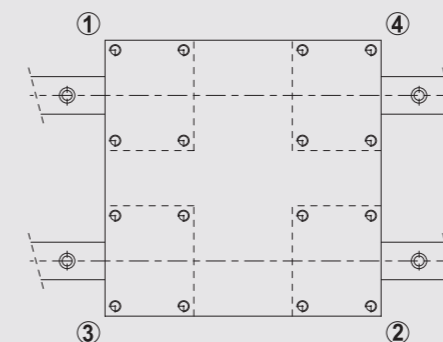

- Place the table gently on the blocks. Next, tighten the block mounting bolts temporarily.
- Push the blocks against the datum plane of the table and position the table by tightening the push screws.
- The table can be fixed uniformly by tightening the mounting bolts on master guide side and subsidiary side in 1 to 4 sequences.

1-5-3 Installation of the Master Guide without Push Screws

To ensure parallelism between the subsidiary guide and the master guide without push screws, the following rail installation methods are recommended. The block installation is the same as mentioned previously.

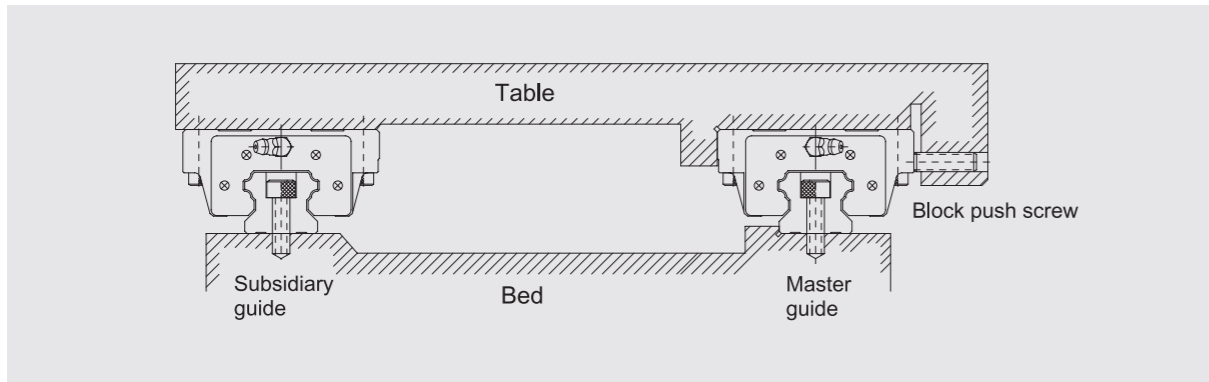

(1) Installation of the rail on the subsidiary guide side

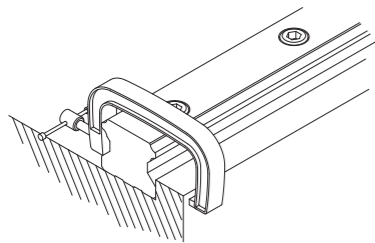

- Using a vice
Place the rail into the mounting plane of the bed. Tighten the mounting bolts temporarily; then use a vice to push the rail against the side datum plane of the bed. Tighten the mounting bolts in sequence to the specified torque.

(2) Installation of the rail on the subsidiary guide side

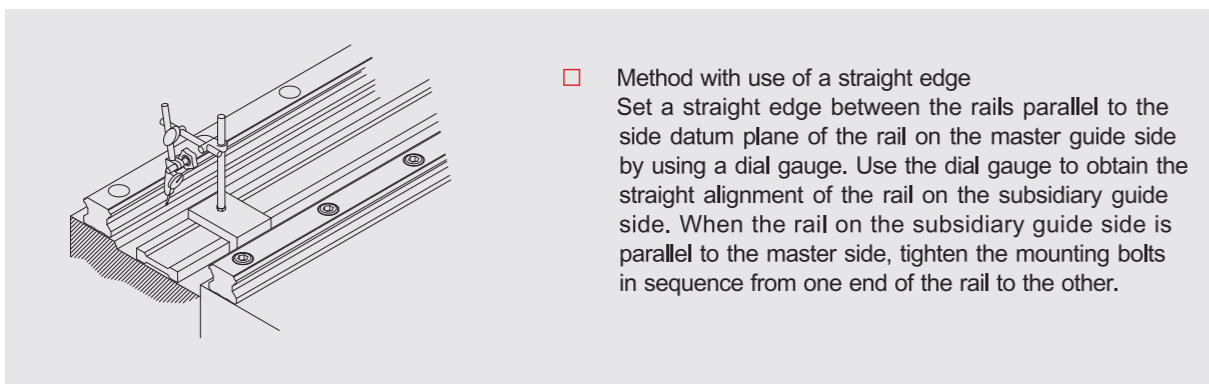

- Method with use of a straight edge
Set a straight edge between the rails parallel to the side datum plane of the rail on the master guide side by using a dial gauge. Use the dial gauge to obtain the straight alignment of the rail on the subsidiary guide side. When the rail on the subsidiary guide side is parallel to the master side, tighten the mounting bolts in sequence from one end of the rail to the other.

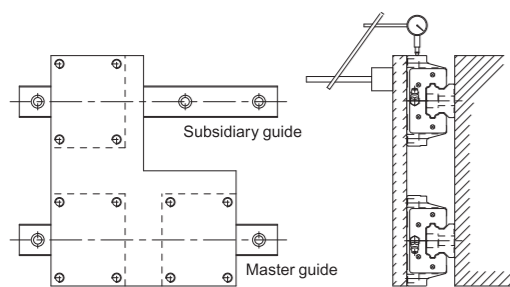

- Method with use of a table
Fix two blocks on the master guide side to the table. Temporarily fix the rail and one block on the subsidiary guide side to the bed and the table. Fix a dial gauge stand on the table surface and bring it into contact with the side of the block on the subsidiary guide side. Move the table from one end of the rail to the other. While aligning the rail on the subsidiary side parallel to the rail on the master guide side, tighten the bolts in sequence.

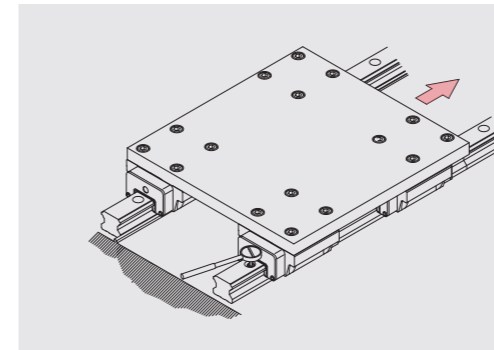

- Method following the master guide side
When a rail on the master guide side is correctly tightened, fix both blocks on the master guide side and one of the two blocks on the subsidiary guide side completely to the table. When moving the table from one end of the rail, tighten the mounting bolts on the subsidiary guide side completely.

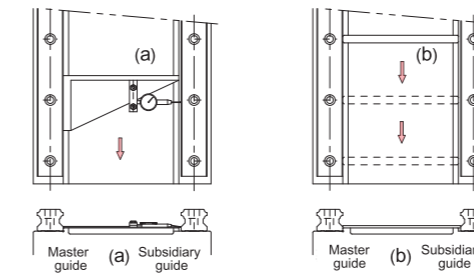

- Method with use of a jig
Use a special jig to ensure the rail position on the subsidiary guide side. Tighten the mounting bolts to the specified torque in sequence.

1-5-4 When there is no Side Surface of the Bed on the Master Guide Side

To ensure parallelism between the subsidiary guide and the master guide when there is no side surface, the following rail installation method is recommended. The installation of the blocks is the same as mentioned previously.

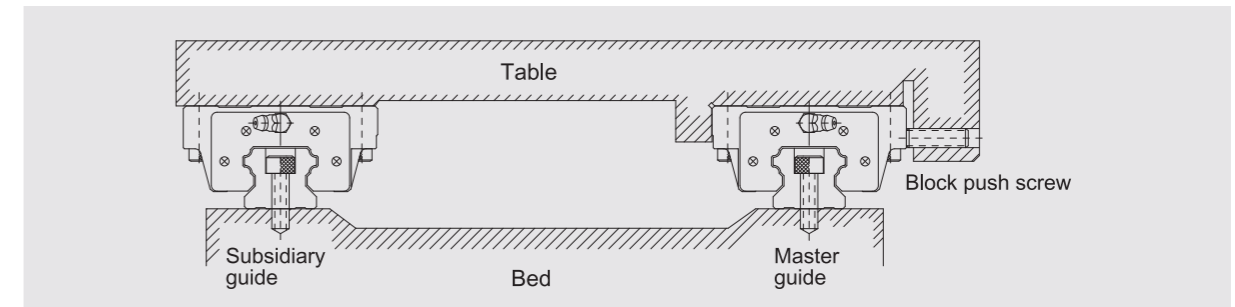

(1) Installation of the rail on the master guide side

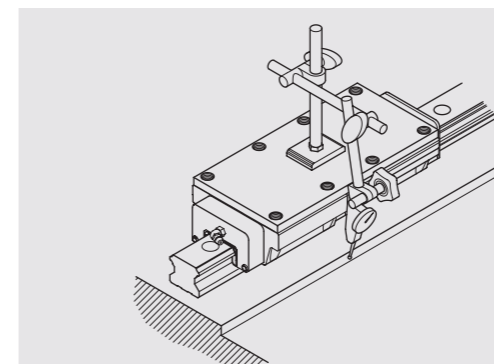

- Using a provisional datum plane
Two blocks are fixed in close contact by the measuring plate. A datum plane provided on the bed is used for straight alignment of the rail from one end to the other. Move the blocks and tighten the mounting bolts to the specified torque in sequence.

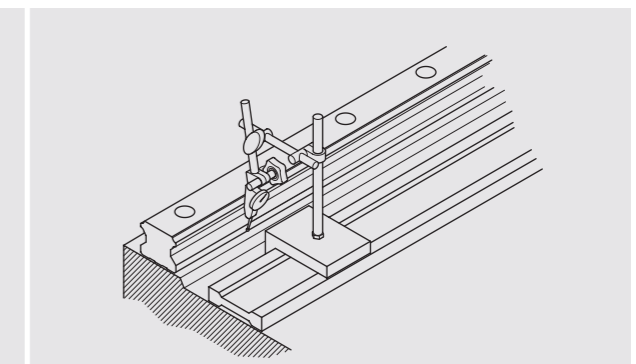

- Method with use of a straight edge
Use a dial gauge and a straight edge to confirm the straightness of the side datum plane of the rail from one end to the other. Make sure the mounting bolts are tightened securely in sequence.

(2) Installation of the rail on the subsidiary guide side

The method of installation for the rail on the subsidiary guide side is the same as the case without push screws.

2. LIMON Linear Guideway Classification

In an effort to meet customer's requirement and service needs LIMON offers several different types of guides. We supply the H series which is suitable for CNC machineries, the E series for automation industries, the R series for high rigidity applications, and the miniature series MN/MW for medical devices and semiconductor equipment, also for high technology industries, LIMON has developed the H and E series with high speed and quiet characteristics.

(1) Types & series

Table 2-1 Types & Series

Series	Assembly Height	Load	Square	Flange	Drilled hole	Combination
			Tap hole	Tap hole		
H	High	Heavy Load	HH-CA	-	-	-
		Super Heavy Load	HH-HA	-	-	-
	Low	Heavy Load	HL-CA	HW-CA	HW-CB	HW-CC
		Super Heavy Load	HL-HA	HW-HA	HW-HB	HW-HC
E	Low	Medium Load	EH-SA	EW-SA	EW-SB	EW-SC
		Heavy Load	EH-CA	EW-CA	EW-CB	EW-CC
MN	-	Standard	MN-M-C-O	-	-	-
		Long	MN-M-H-O	-	-	-
MW	-	Standard	MW-M-C-O	-	-	-
		Long	MW-M-H-O	-	-	-
QH	High	Heavy Load	HH-CA	-	-	-
		Super Heavy Load	HH-HA	-	-	-
	Low	Heavy Load	-	QHW-CA	QHW-CB	QHW-CC
		Super Heavy Load	-	QHW-HA	QHW-HB	QHW-HC
QE	Low	Medium Load	QEH-SA	QEW-SA	QEW-SB	-
		Heavy Load	QEH-CA	QEW-CA	QEW-CB	-
R	High	Heavy Load	RH-CA	-	-	-
		Super Heavy Load	RH-HA	-	-	-
	Low	Heavy Load	RL-CA	-	-	RW-CC
		Super Heavy Load	RL-HA	-	-	RW-HC

2-1 H Series - Heavy Load Ball Type Linear Guideway

H series linear guideways are designed with load capacity and rigidity higher than other similar products with circular-arc groove and structure optimization. It features equal load ratings in the radial, reverse radial and lateral directions, and self-aligning to absorb installation-error. Thus, LIMON H series linear guideways can achieve a long life with high speed, high accuracy and smooth linear motion.

2-1-1 Features of H Series

(1) Self-aligning capability

By design, the circular-arc groove has contact points at 45 degrees. H series can absorb most installation errors due to surface irregularities and provide smooth linear motion through the elastic deformation of rolling elements and the shift of contact points. Self-aligning capability, high accuracy and smooth operation can be obtained with an easy installation.

(2) Interchangeability

Because of precision dimensional control, the dimensional tolerance of H series can be kept in a reasonable range, which means that any blocks and any rails in a specific series can be used together while maintaining dimensional tolerance. And a retainer is added to prevent the balls from falling out when the blocks are removed from the rail.

(3) High rigidity in all four directions

Because of the four-row design, the H series linear guideway has equal load ratings in the radial, reverse radial and lateral directions. Furthermore, the circular-arc groove provides a wide-contact width between the balls and the groove raceway allowing large permissible loads and high rigidity.

2-1-2 Construction of H Series

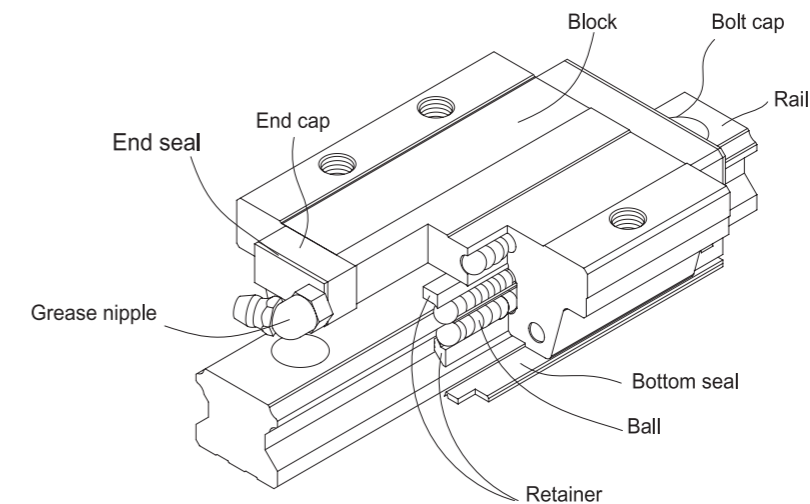

- Rolling circulation system: Block, Rail, End Cap and Retainer
- Lubrication system: Grease Nipple and Piping Joint
- Dust protection system: End seal, Bottom Seal, Bolt Cap, Double Seals and Scraper

2-1-3 Model Number of H Series

H series guideways can be classified into non-interchangeable and interchangeable types. The sizes are identical. The only difference between the two types is that the interchangeable type of blocks and rails can be freely exchanged, and their accuracy can reach up to P class. The model number of H series contains the size, type, accuracy class, preload class, etc..

(1) Non-interchangeable type

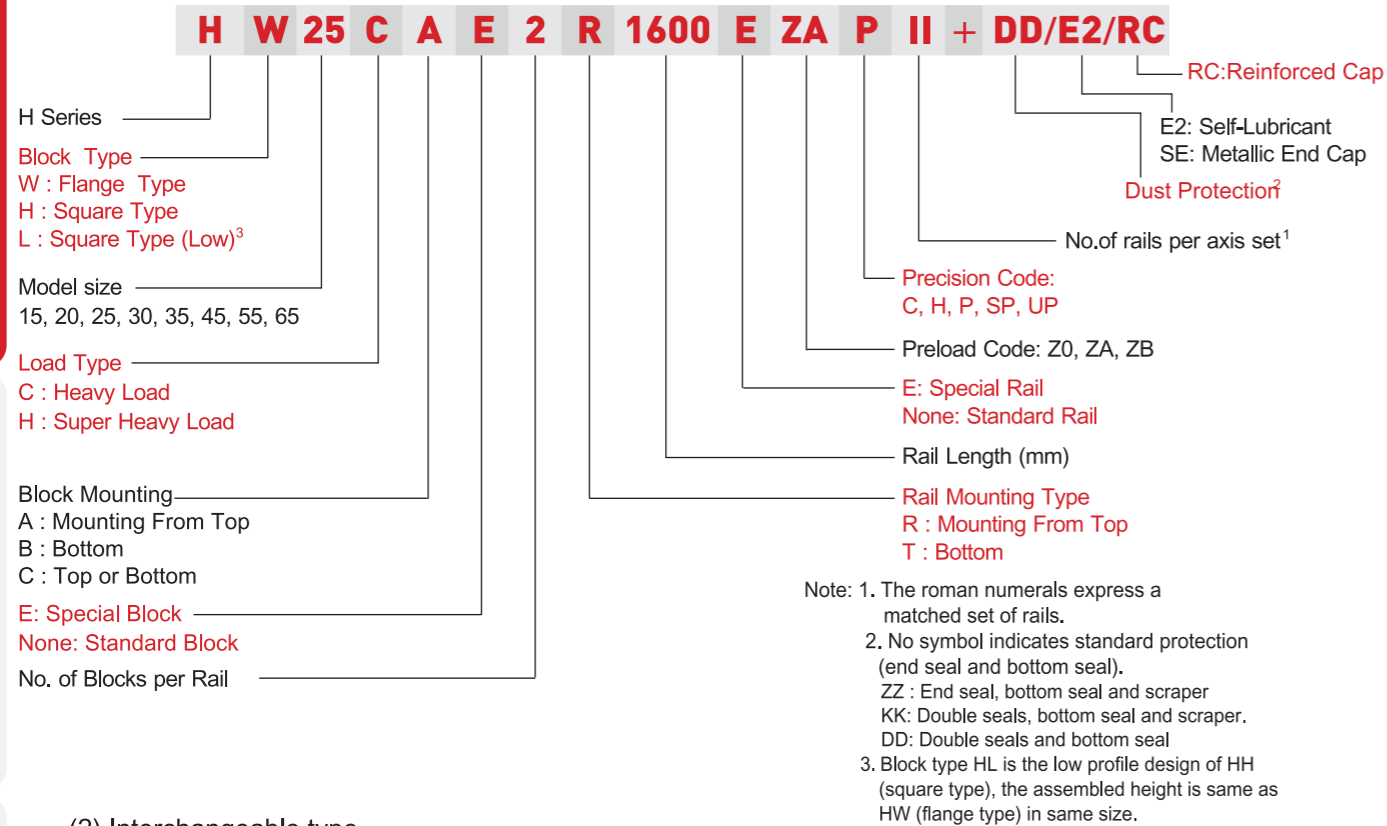

(2) Interchangeable type

□ Model Number of H Block

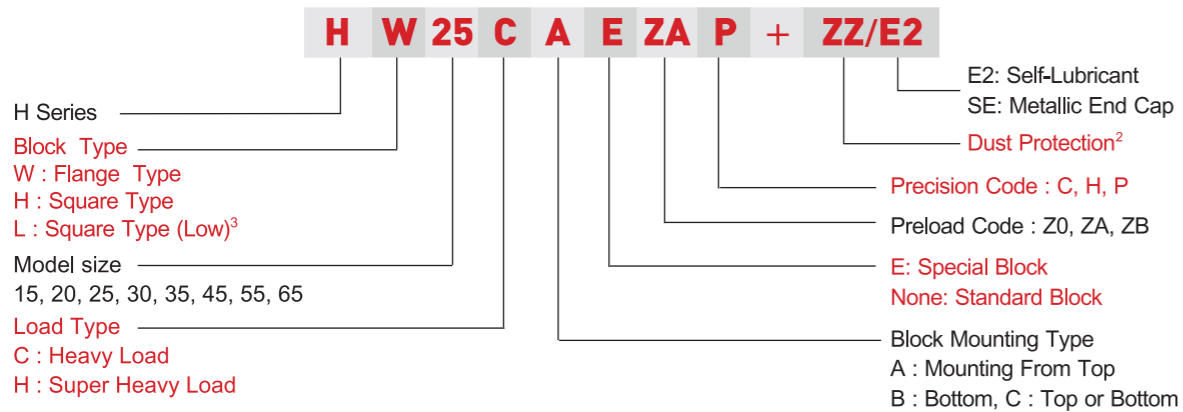

□ Model Number of H Rail

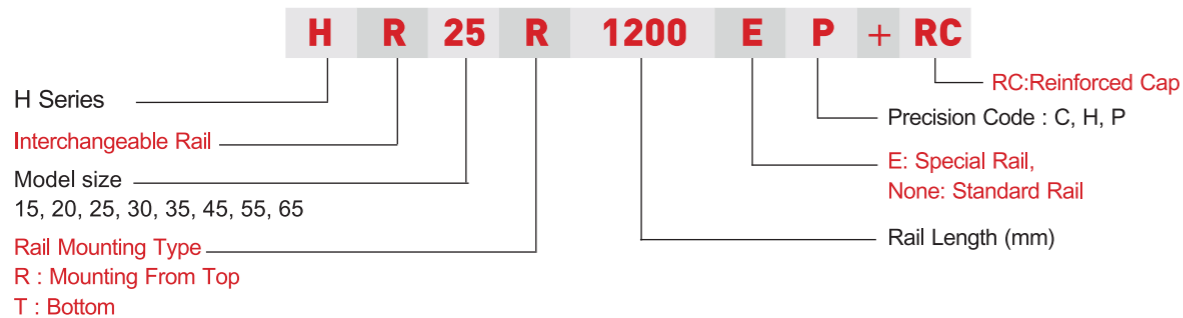

2-1-4 Types

(1) Block types

There're two types of blocks: flange and square. The flange type is suitable for heavy moment load application because of the lower assembly height and wider mounting surface.

Table 2-1-1 Block Types

Type	Model	Shape	Height (mm)	Rail Length (mm)	Main Application
Square	HH-CA HH-HA		28	100	<input type="checkbox"/> Machine Centers <input type="checkbox"/> NC Lathes <input type="checkbox"/> Grinding Machines <input type="checkbox"/> Precision Machining Machines <input type="checkbox"/> Heavy Cutting Machines <input type="checkbox"/> Automation Devices <input type="checkbox"/> Transportation Equipment <input type="checkbox"/> Measuring Equipment <input type="checkbox"/> Devices Requiring High Positional Accuracy
			90	4000	
Square	HL-CA HL-HA		24	100	<input type="checkbox"/> Machine Centers <input type="checkbox"/> NC Lathes <input type="checkbox"/> Grinding Machines <input type="checkbox"/> Precision Machining Machines <input type="checkbox"/> Heavy Cutting Machines <input type="checkbox"/> Automation Devices <input type="checkbox"/> Transportation Equipment <input type="checkbox"/> Measuring Equipment <input type="checkbox"/> Devices Requiring High Positional Accuracy
			70	4000	
Flange	HW-CA HW-HA		24	100	<input type="checkbox"/> Machine Centers <input type="checkbox"/> NC Lathes <input type="checkbox"/> Grinding Machines <input type="checkbox"/> Precision Machining Machines <input type="checkbox"/> Heavy Cutting Machines <input type="checkbox"/> Automation Devices <input type="checkbox"/> Transportation Equipment <input type="checkbox"/> Measuring Equipment <input type="checkbox"/> Devices Requiring High Positional Accuracy
			90	4000	
Flange	HW-CB HW-HB		24	100	<input type="checkbox"/> Machine Centers <input type="checkbox"/> NC Lathes <input type="checkbox"/> Grinding Machines <input type="checkbox"/> Precision Machining Machines <input type="checkbox"/> Heavy Cutting Machines <input type="checkbox"/> Automation Devices <input type="checkbox"/> Transportation Equipment <input type="checkbox"/> Measuring Equipment <input type="checkbox"/> Devices Requiring High Positional Accuracy
			90	4000	
Flange	HW-CC HW-HC		24	100	<input type="checkbox"/> Machine Centers <input type="checkbox"/> NC Lathes <input type="checkbox"/> Grinding Machines <input type="checkbox"/> Precision Machining Machines <input type="checkbox"/> Heavy Cutting Machines <input type="checkbox"/> Automation Devices <input type="checkbox"/> Transportation Equipment <input type="checkbox"/> Measuring Equipment <input type="checkbox"/> Devices Requiring High Positional Accuracy
			90	4000	

(2) Rail types

Besides the standard top mounting type, the bottom mounting type is also available.

Table 2-1-2 Rail Types



2-1-5 Accuracy

The accuracy of H series can be classified into normal (C), high (H), precision (P), super precision (SP), ultra precision (UP), five classes. Please choose the class by referring the accuracy of applied equipment.

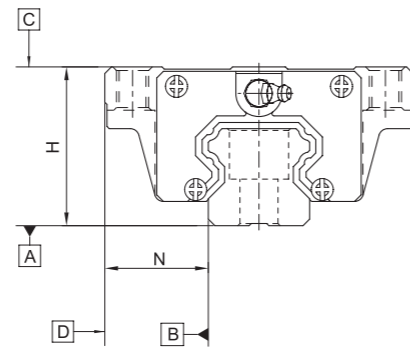

(1) Accuracy of non-interchangeable guideways

Table 2-1-3 Accuracy Standards

Item	H - 15, 20				
	Normal (C)	High (H)	Precision (P)	Super Precision (SP)	Ultra Precision (UP)
Dimensional tolerance of height H	± 0.1	± 0.03	0 -0.03	0 -0.015	0 -0.008
Dimensional tolerance of width N	± 0.1	± 0.03	0 -0.03	0 -0.015	0 -0.008
Variation of height H	0.02	0.01	0.006	0.004	0.003
Variation of width N	0.02	0.01	0.006	0.004	0.003
Running parallelism of block surface C to surface A	See Table 2-1-7				
Running parallelism of block surface D to surface B	See Table 2-1-7				

Table 2-1-4 Accuracy Standards

Item	H - 25, 30, 35				
	Normal (C)	High (H)	Precision (P)	Super Precision (SP)	Ultra Precision (UP)
Dimensional tolerance of height H	± 0.1	± 0.04	0 -0.04	0 -0.02	0 -0.01
Dimensional tolerance of width N	± 0.1	± 0.04	0 -0.04	0 -0.02	0 -0.01
Variation of height H	0.02	0.015	0.007	0.005	0.003
Variation of width N	0.03	0.015	0.007	0.005	0.003
Running parallelism of block surface C to surface A	See Table 2-1-7				
Running parallelism of block surface D to surface B	See Table 2-1-7				

Table 2-1-5 Accuracy Standards

Item	H - 45, 55		
	Normal (C)	High (H)	Precision (P)
Dimensional tolerance of height H	± 0.1	± 0.05	± 0.025
Dimensional tolerance of width N	± 0.1	± 0.05	± 0.025
Variation of height H	0.03	0.015	0.007
Variation of width N	0.03	0.02	0.01
Running parallelism of block surface C to surface A	See Table 2-1-7		
Running parallelism of block surface D to surface B	See Table 2-1-7		

Table 2-1-6 Accuracy Standards

Item	H - 65		
	Normal (C)	High (H)	Precision (P)
Dimensional tolerance of height H	± 0.1	± 0.07	± 0.035
Dimensional tolerance of width N	± 0.1	± 0.07	± 0.035
Variation of height H	0.03	0.02	0.01
Variation of width N	0.03	0.025	0.015
Running parallelism of block surface C to surface A	See Table 2-1-7		
Running parallelism of block surface D to surface B	See Table 2-1-7		

(2) Accuracy of running parallelism

Table 2-1-7 Accuracy of Running Parallelism

Rail Length (mm)	Accuracy (μm)				
	C	H	P	SP	UP
~ 100	12	7	3	2	2
100 ~ 200	14	9	4	2	2
200 ~ 300	15	10	5	3	2
300 ~ 500	17	12	6	3	2
500 ~ 700	20	13	7	4	2
700 ~ 900	22	15	8	5	3
900 ~ 1,100	24	16	9	6	3
1,100 ~ 1,500	26	18	11	7	4
1,500 ~ 1,900	28	20	13	8	4
1,900 ~ 2,500	31	22	15	10	5
2,500 ~ 3,100	33	25	18	11	6
3,100 ~ 3,600	36	27	20	14	7
3,600 ~ 4,000	37	28	21	15	7

2-1-6 Preload

(1) Definition

A preload can be applied to each guideway. Oversized balls are used. Generally, a linear motion guideway has a negative clearance between groove and balls in order to improve stiffness and maintain high precision. The figure shows the load is multiplied by the preload, the rigidity is doubled and the deflection is reduced by one half. The preload no larger than ZA would be recommended for the model size under H20 to avoid an over-preload affecting the guideway's life.

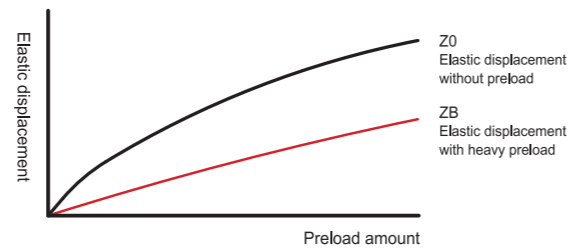

(2) Preload classes

LIMON offers three classes of standard preload for various applications and conditions.

Table 2-1-8 Preload Classes

Class	Code	Preload	Condition	Examples of Application
Light Preload	Z0	0~ 0.02C	Certain load direction, low impact, low precision required	Transportation devices, auto-packing machines, X-Y axis for general industrial machines, welding machines, welders
Medium Preload	ZA	0.05C~0.07C	High precision required	Machining centers, Z axis for general industrial machines, EDM, NC lathes, Precision X-Y tables, measuring equipment
Heavy Preload	ZB	0.10C~ 0.12C	High rigidity required, with vibration and impact	Machining centers, grinding machines, NC lathes, horizontal and vertical milling machines, Z axis of machine tools, Heavy cutting machines

Class	Interchangeable Guideway	Non-Interchangeable Guideway
Preload classes	Z0, ZA	Z0, ZA, ZB

Note: The "C" in the preload column denotes basic dynamic load rating.

2-1-7 Lubrication

(1) Grease

- Grease nipple

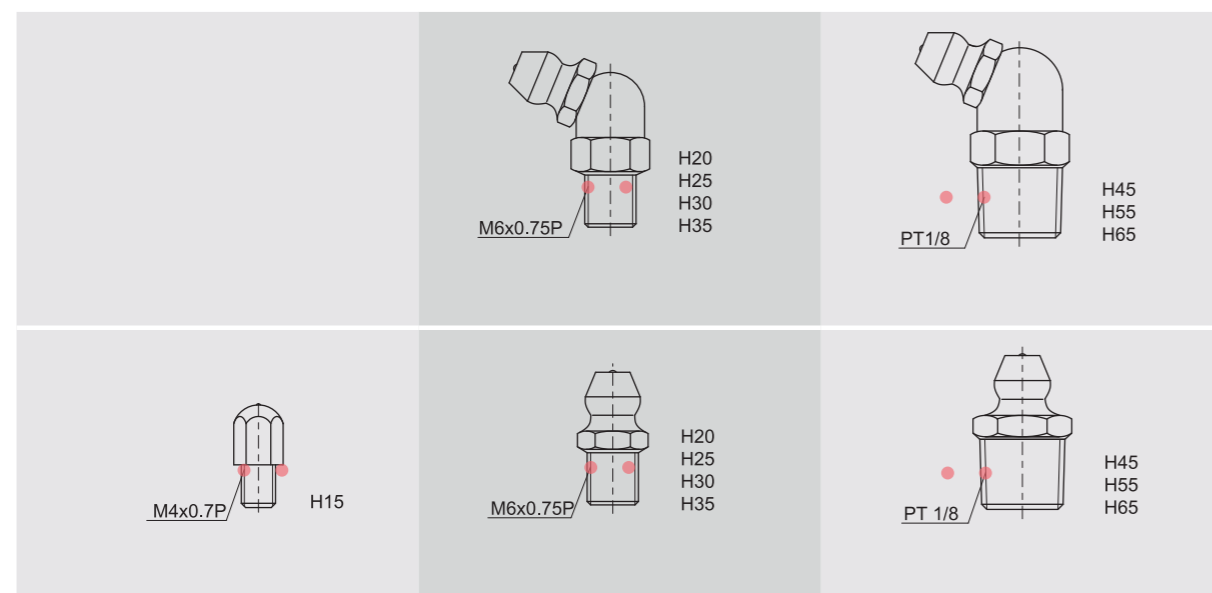

- Mounting location

The standard location of the grease fitting is at both ends of the block, but the nipple can be mounted at each side of block. For lateral installation, we recommend that the nipple be mounted at the non-reference side, otherwise please contact us. It is possible to perform lubrication by using the oil-piping joint.

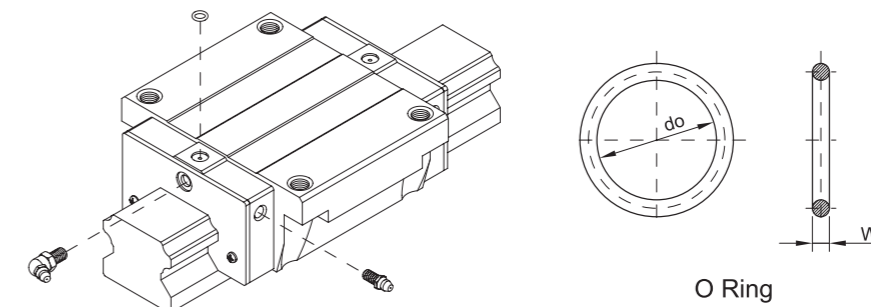
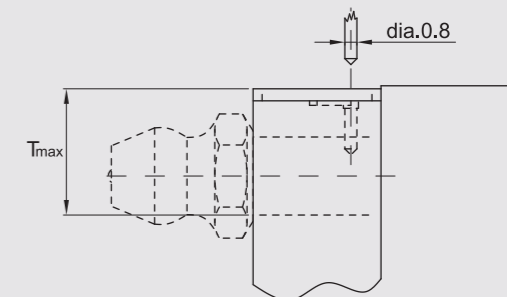

Table 2-1-9 O-Ring size and max. permissible depth for piercing

Size	O-Ring		Lube hole at top: max. permissible depth for piercing
	do (mm)	W (mm)	T _{max} (mm)
H15	2.5±0.15	1.5±0.15	3.75
H20	4.5±0.15	1.5±0.15	5.7
H25	4.5±0.15	1.5±0.15	5.8
H30	4.5±0.15	1.5±0.15	6.3
H35	4.5±0.15	1.5±0.15	8.8
H45	4.5±0.15	1.5±0.15	8.2
H55	4.5±0.15	1.5±0.15	11.8
H65	4.5±0.15	1.5±0.15	10.8



- The lubricant amount for a block filled with grease

Table 2-1-10 The lubricant Amount for a Block Filled with Grease

Size	Heavy load (cm ³)	Super heavy load (cm ³)	Size	Heavy load (cm ³)	Super heavy load (cm ³)
H15	1	-	H35	10	12
H20	2	3	H45	17	21
H25	5	6	H55	26	33
H30	7	8	H65	50	61

- Frequency of replenishment

Check the grease every 100 km, or every 3-6 months.

Oil refilling rate
Table 2-1-11

Size	Refilling rate (cm ³ /hr)	Size	Refilling rate (cm ³ /hr)
H15	0.2	H35	0.3
H20	0.2	H45	0.4
H25	0.3	H55	0.5
H30	0.3	H65	0.6

2-1-8 Dust Proof Accessories

(1) Codes of standard dust proof accessories

If the following accessories are needed, please add the code followed by the model number.

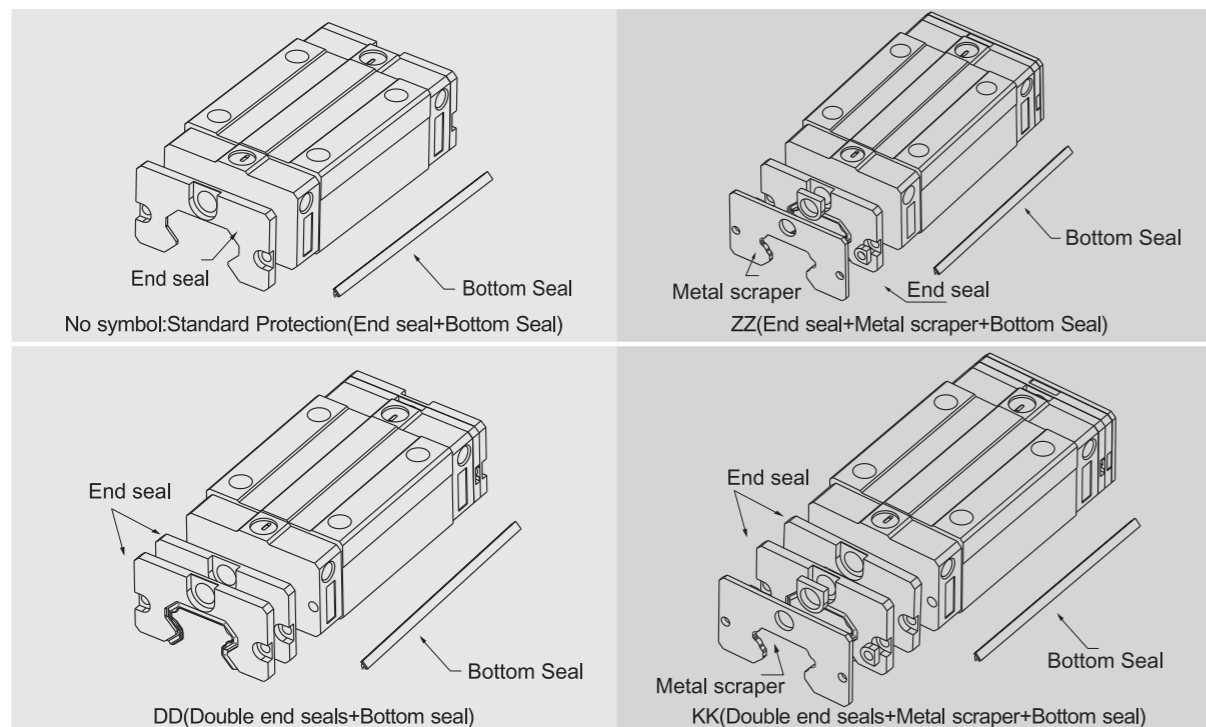

Table 2-1-12 unit:mm

Size	Overall block length (L)			
	SS	ZZ	DD	KK
H15C	60.5	64.1	65.5	69.1
H20C	76.7	80.3	82.5	86.1
H20H	91.4	95	97.2	100.8
H25C	84	87.6	90	93.6
H25H	104.6	108.2	110.6	114.2
H30C	98.4	102	104.6	108.2
H30H	121.4	125	127.6	131.2
H35C	112.4	116	118.8	122.4
H35H	138.2	141.8	144.6	148.2
H45C	137.4	141	145.4	149
H45H	169.2	172.8	177.2	180.8

(4) Function of dust proof accessories

End seal and bottom seal

To prevent life reduction caused by iron chips or dust entering the block.

Double seals

Enhances the wiping effect, foreign matter can be completely wiped off.

Table 2-1-13 Dimensions of end seal

Size	Thickness (t1) (mm)	Size	Thickness (t1) (mm)
H15 ES	3	H35 ES	3.2
H20 ES	3.5	H45 ES	4.5
H25 ES	3.5	H55 ES	4.5
H30 ES	3.2	H65 ES	6

Scraper

The scraper removes high-temperature iron chips and larger foreign objects.

Table 2-1-14 Dimensions of scraper

Size	Thickness (t2) (mm)	Size	Thickness (t2) (mm)
H15 SC	1.5	H35 SC	1.5
H20 SC	1.5	H45 SC	1.5
H25 SC	1.5	H55 SC	1.5
H30 SC	1.5	H65 SC	1.5

Top Seal

Top seal can efficiently avoid dust from the surface of rail or tapping hole getting inside the block.

Bolt caps for rail mounting holes

Caps are used to cover the mounting holes to prevent chips or other foreign objects from collecting in the holes. The caps will be enclosed in each rail package.

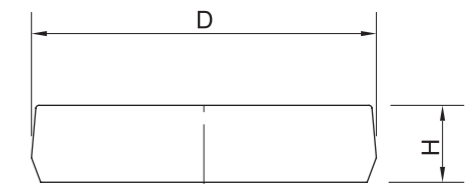
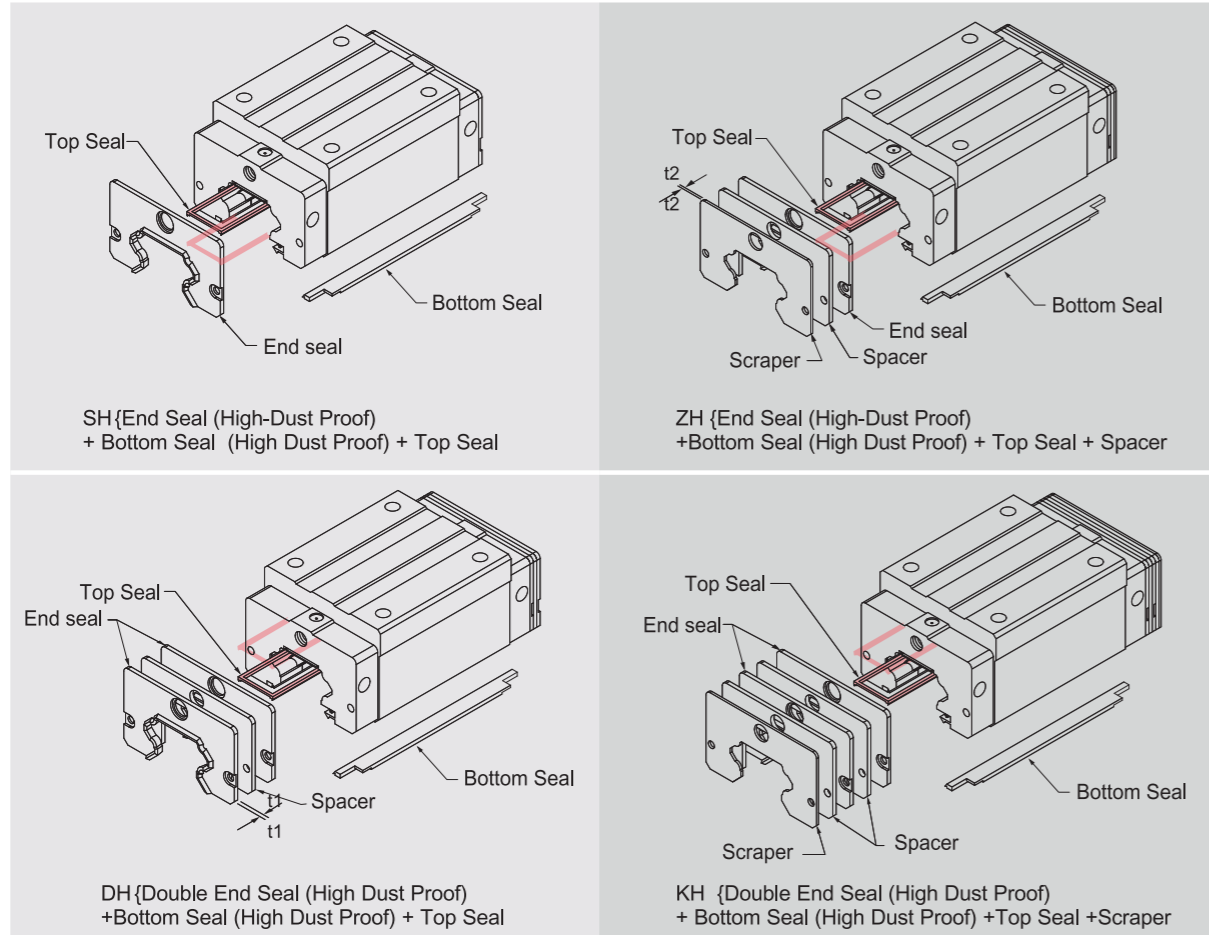

Table 2-1-15 Dimensions of Bolt Caps for Rail Mounting Holes

Rail size	Bolt size	Diameter(D) (mm)	Thickness(H) (mm)	Rail size	Bolt size	Diameter(D) (mm)	Thickness(H) (mm)
HR15	M4	7.65	1.1	HR35	M8	14.25	3.3
HR20	M5	9.65	2.2	HR45	M12	20.25	4.6
HR25	M6	11.2	2.5	HR55	M14	23.5	5.5
HR30	M8	14.25	3.3	HR65	M16	26.6	5.5

(2) Codes of high-dust proof accessories

LIMON develops many kinds of dust proof accessories for different application and working environment to avoid dust or debris. If the following accessories are needed, please add the code followed by the model number.



Note: 1. The available size for high dust proof accessories are HH20(C/H), 25(C/H), 30(C/H), 35(C/H) and 45C.
 2. The value of friction force will increase 0.6~1.2 kgf.

2-1-9 Friction

The maximum value of resistance per end seal are as shown in the table.

Table 2-1-16 Seal Resistance

Size	Resistance N (kgf)	Size	Resistance N (kgf)
H15	1 (0.1)	H35	3 (0.31)
H20	1.7 (0.1)	H45	4 (0.41)
H25	2 (0.2)	H55	5 (0.51)
H30	2.6 (0.27)	H65	6 (0.61)

Note: 1kgf=9.81N

2-1-10 The Accuracy Tolerance of Mounting Surface

(1) The accuracy tolerance of rail-mounting surface
 Because of the Circular-arc contact design, the H linear guideway can compensate for some surface-error on installation and still maintain smooth linear motion. As long as the accuracy requirements for the mounting surface are followed, high accuracy and rigidity of linear motion of the guideway can be obtained without any difficulty. In order to satisfy the needs of fast installation and smooth movement, LIMON offers the normal clearance type of preload to customers of its high absorption ability of the deviation in mounting surface accuracy.

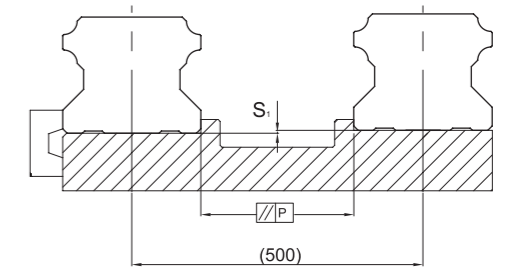

(2) The parallelism tolerance of reference surface (P)

Table 2-1-17 Max. Parallelism Tolerance (P)

unit: μm

Size	Preload classes		
	Z0	ZA	ZB
H15	25	18	13
H20	25	20	18
H25	30	22	20
H30	40	30	27
H35	50	35	30
H45	60	40	35
H55	70	50	45
H65	80	60	55

(3) The accuracy tolerance of reference surface height

Table 2-1-18 Max. Tolerance of Reference Surface Height (S_1)

unit: μm

Size	Preload classes		
	Z0	ZA	ZB
H15	130	85	35
H20	130	85	50
H25	130	85	70
H30	170	110	90
H35	210	150	120
H45	250	170	140
H55	300	210	170
H65	350	250	200

2-1-11 Cautions for Installation

(1) Shoulder heights and fillets

Improper shoulder heights and fillets of mounting surfaces will cause a deviation in accuracy and the interference with the chamfered part of the rail or block. As long as the recommended shoulder heights and fillets are followed, installation inaccuracies should be eliminated.

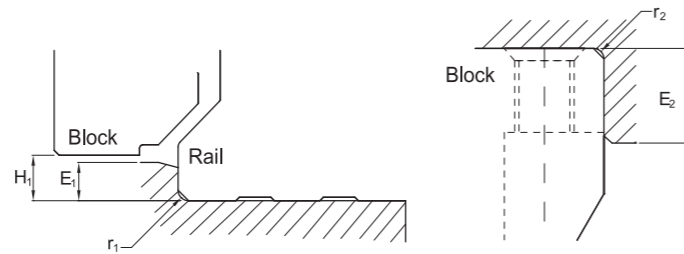

Table 2-1-19 Shoulder Heights and Fillets

Size	Max. radius of fillets r_1 (mm)	Max. radius of fillets r_2 (mm)	Shoulder height of the rail E_1 (mm)	Shoulder height of the block E_2 (mm)	Clearance under block H_1 (mm)
H15	0.5	0.5	3	4	4.3
H20	0.5	0.5	3.5	5	4.6
H25	1.0	1	5	5	5.5
H30	1.0	1	5	5	6
H35	1.0	1	6	6	7.5
H45	1.0	1	8	8	9.5
H55	1.5	1.5	10	10	13
H65	1.5	1.5	10	10	15

(2) Tightening Torque of Bolts for Installation

Improper tightening of bolts will seriously influence the accuracy of Linear Guideway installation. The following tightening torques for different sizes of bolts are recommended.

Table 2-1-20 Mounting Torque

Size	Bolt size	Torque N-cm (kgf-cm)		
		Iron	Casting	Aluminum
H15	M4×0.7P×16L	392 (40)	274 (28)	206 (21)
H20	M5×0.8P×16L	883 (90)	588 (60)	441 (45)
H25	M6×1P×20L	1373 (140)	921 (94)	686 (70)
H30	M8×1.25P×25L	3041 (310)	2010 (205)	1470 (150)
H35	M8×1.25P×25L	3041 (310)	2010 (205)	1470 (150)
H45	M12×1.75P×35L	11772 (1200)	7840 (800)	5880 (600)
H55	M14×2P×45L	15696 (1600)	10500 (1100)	7840 (800)
H65	M16×2P×50L	19620 (2000)	13100 (1350)	9800 (1000)

2-1-12 Dimensions for H Series

(1) HH-CA / HH-HA

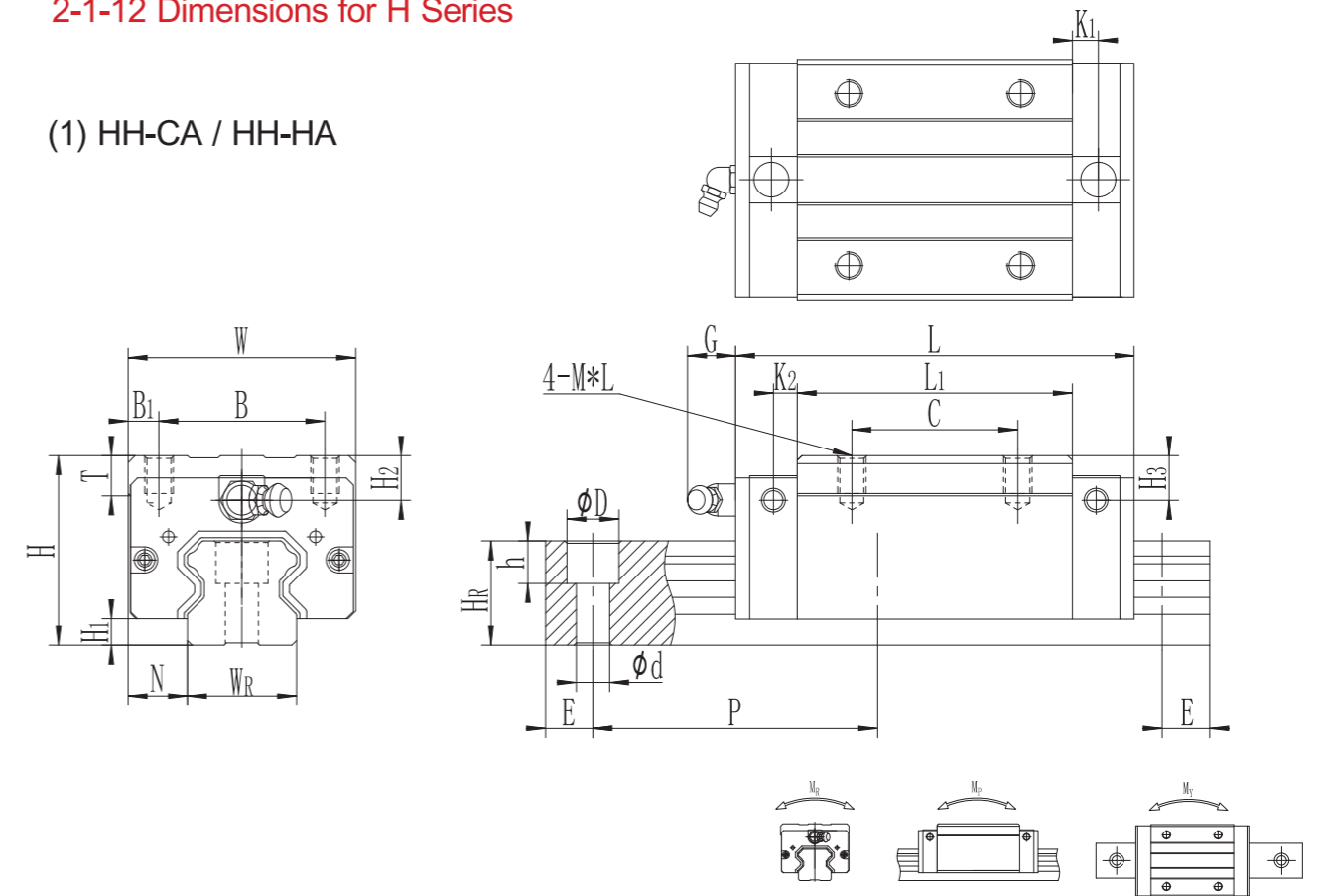

Model No.	Dimensions of Assembly (mm)		Dimensions of Block(mm)														Dimensions of Rail (mm)						Mounting Bolt for Rail (mm)	Basic Dynamic Load Rating C(KN)	Basic Static Load Rating CO (KN)	Static Rated Moment			Weight				
	H	H1	N	W	B	B1	C	L1	L	K1	K2	G	M*1	T	H2	H3	WR	HR	D	h	d	P				E	MR (KN-m)	MP (KN-m)	MY (KN-m)	Block kg	Rail kg/m		
HH15CA	28	4.4	9.5	34	26	4	26	39.5	61.1	3.35	4.75	5.5	M4×5	6	8	8	15	15	7.5	5.3	4.5	60	20	M4×16	10.59	16.19	0.11	0.09	0.09	0.20	1.42		
HH20CA	30	4.3	12	44	32	6	36	50.5	76.5	5	6	12	M5×6	8	6	6	20	17.5	9.5	8.5	6	60	20	M5×16	17.2	25.6	0.25	0.18	0.18	0.33	2.2		
HH20HA							50	65.2	91.2																								
HH25CA	40	5.6	12.5	48	35	6.5	35	58	82	5	6	12	M6×8	8	10	9.5	23	22	11	9	7	60	20	M6×20	25.11	36.42	0.41	0.32	0.32	0.53	3.25		
HH25HA							50	78.6	102.6																								
HH30CA	45	6	16	60	40	10	40	70	98	6.5	5.5	12	M8×10	8.5	10	9	28	26	14	12	9	80	20	M8×25	34.93	49.58	0.58	0.5	0.5	0.90	4.49		
HH30HA							60	93	121																								
HH35CA	55	7.4	18	70	50	10	50	80	112	5.5	6.5	12	M8×12	10.2	16	15	34	29	14	12	9	80	20	M8×25	48.5	57.6	1.08	0.78	0.78	1.50	6.36		
HH35HA							72	105.8	137.8																								
HH45CA	70	9.5	20.5	86	60	13	60	97	137	4.8	8	13	M10×17	16	21	20	45	38	20	17	14	105	22.5	M12×35	75.26	100.2	1.8	1.35	1.35	2.75	10.45		
HH45HA							80	128.8	168.8																								
HH55CA	80	13	23.5	100	75	12.5	75	117.7	161.7	6	11	13	M12×18	17.5	22	29	53	44	23	20	16	120	30	M14×45	112.33	145.64	3.59	2.5	2.5	4.20	15.12		
HH55HA							95	155.8	199.8																								
HH65CA	90	15	31.5	126	76	25	70	144.2	194.2	6	14	13	M16×20	25	15	15	63	53	26	22	18	150	35	M16×50	160.22	210.37	6.45	4.18	4.18	9.25	21.25		
HH65HA							120	203.6	253.6																								

Note : 1 kgf = 9.81 N

(2) HL-CA / HL-HA

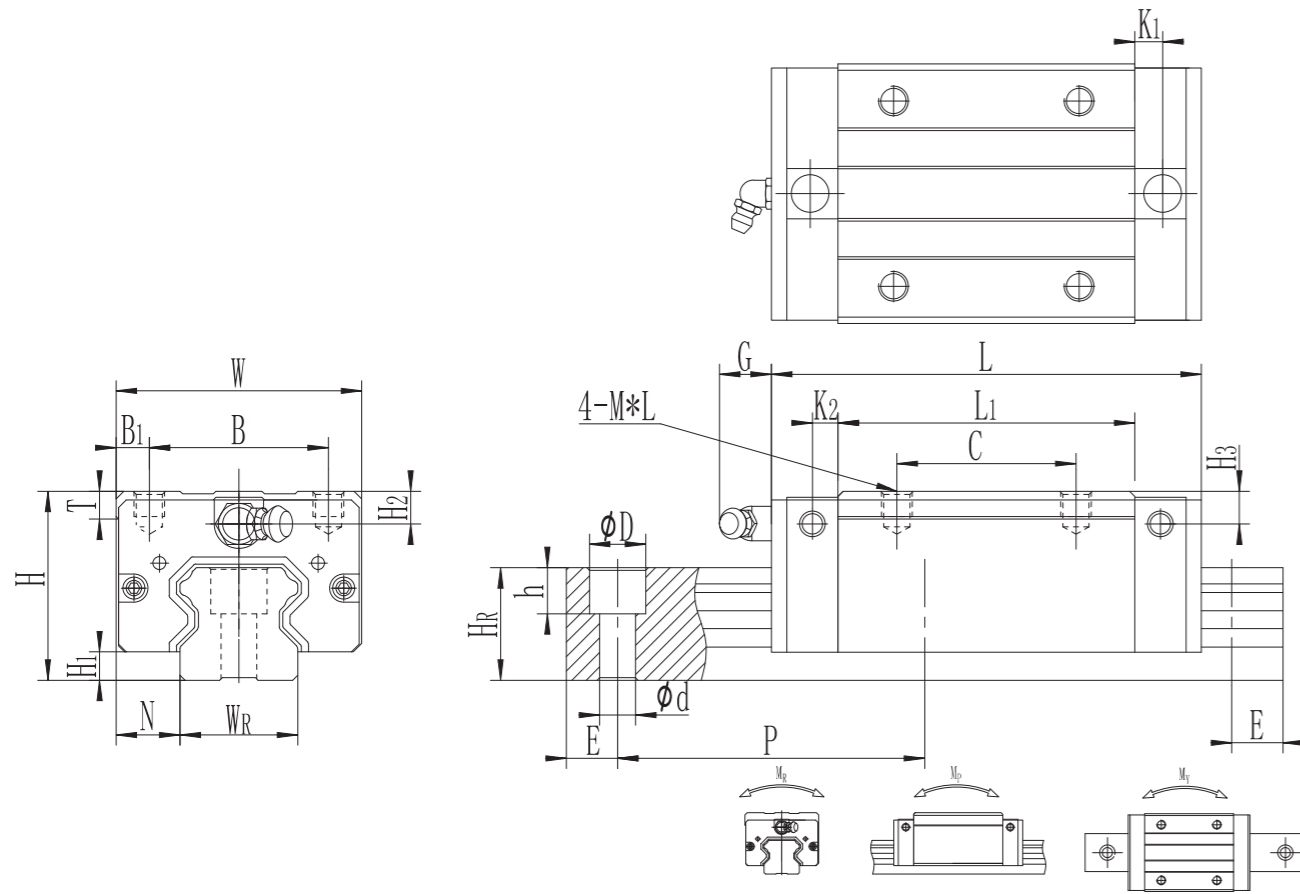

(3) HW-CA / HW-HA

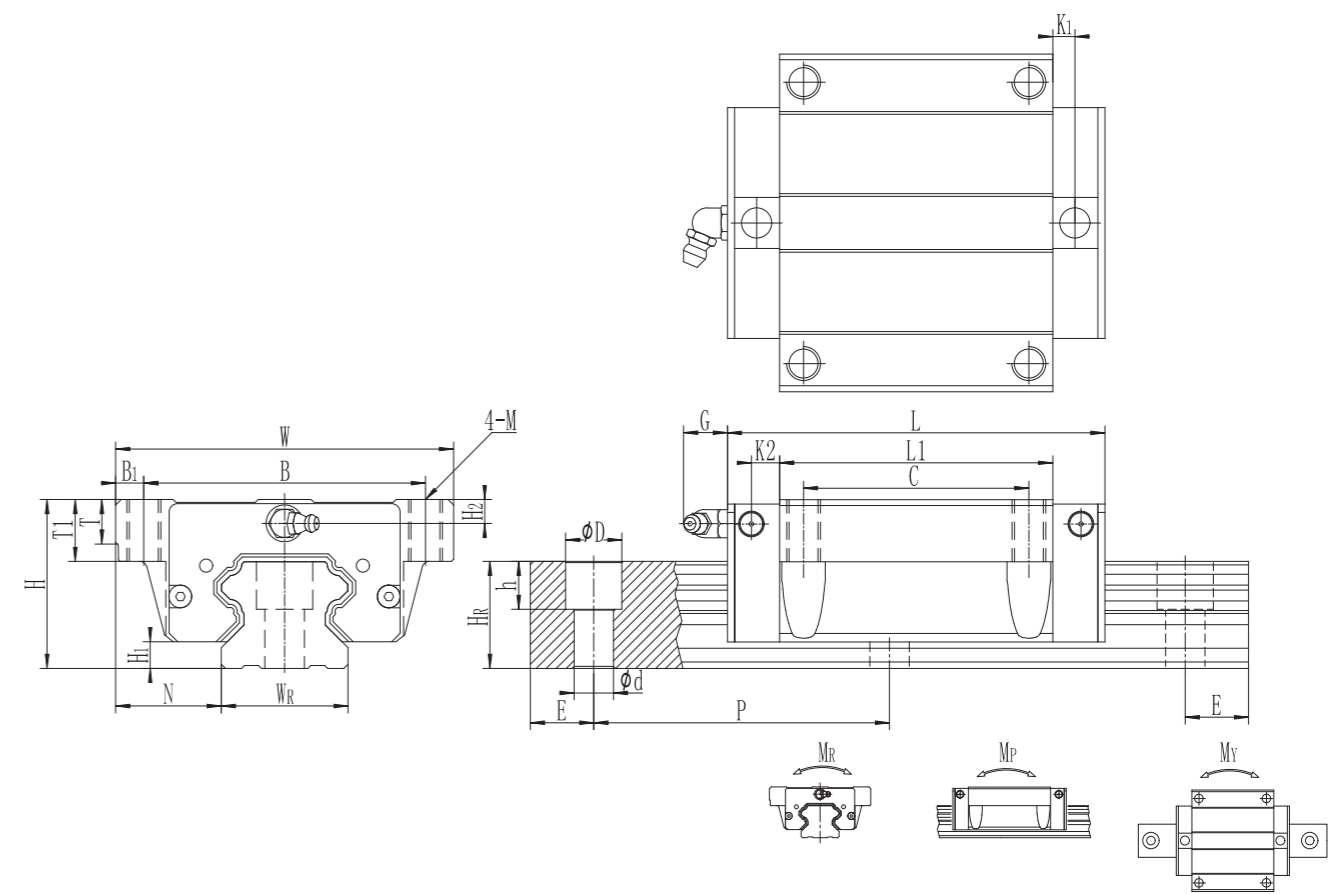

Model No.	Dimensions of Assembly (mm)			Dimensions of Block (mm)										Dimensions of Rail (mm)						Mounting Bolt for Rail (mm)	Basic Dynamic Load Rating C(KN)	Basic Static Load Rating C0(KN)	Static Rated Moment			Weight																	
	H	H1	N	W	B	B1	C	L1	L	K1	K2	G	M	T	H2	H3	WR	HR	D				h	d	P	E	MR	Mp	My	Block kg	Rail kg/m												
HL15CA	24	4.4	9.5	34	26	4	26	39.5	61.1	3.35	4.75	5.5	M4x4	6	4	4	15	15	7.5	5.3	4.5	60	20	M4x16	10.59	16.19	0.11	0.09	0.09	0.20	1.42												
HL25CA	36	5.6	12.5	48	35	6.5	35	58	82		5	6	12	M6x6	8	6	5.5	23	22	11	9	7	60	20	M6x20	25.11	36.42	0.41	0.32	0.32	0.53						3.25						
HL25HA							50	78.6	102.6																																		
HL30CA	42	6	16	60	40	10	40	70	98		6.5	5.5	12	M8x10	8.5	7	6	28	26	14	12	9	80	20	M8x25	34.93	49.58	0.58	0.5	0.5	0.90							4.49					
HL30HA							60	93	121																																		
HL35CA	48	7.4	18	70	50	10	50	80	112		5.5	6.5	12	M8x9	10.2	9	8	34	29	14	12	9	80	20	M8x25	48.5	57.6	1.08	0.78	0.78	1.50							6.36					
HL35HA							72	105.8	137.8																																		
HL45CA	60	9.5	20.5	86	60	13	60	97	137		4.8	8	13	M10x13	16	11	10	45	38	20	17	14	105	22.5	M12x35	75.26	100.2	1.8	1.35	1.35	2.75							10.45					
HL45HA							80	128.8	168.8																																		
HL55CA	70	13	23.5	100	75	12.5	75	117.7	161.7		6	11	13	M12x18	17.5	12	19	53	44	23	20	16	120	30	M14x45	112.33	145.64	3.59	2.5	2.5	4.20							15.12					
HL55HA							95	155.8	199.8																																		

Note : 1 kgf = 9.81 N

Model No.	Dimensions of Assembly (mm)			Dimensions of Block(mm)										Dimensions of Rail (mm)						Mounting Bolt for Rail (mm)	Basic Dynamic Load Rating C(KN)	Basic Static Load Rating C0(KN)	Static Rated Moment			Weight															
	H	H1	N	W	B	B1	C	L1	L	K1	K2	G	M	T	T1	H2	H3	WR	HR				D	h	d	P	E	MR	Mp	My	Block kg	Rail kg/m									
HW15CA	24	4.4	16	47	38	4.5	30	39.5	61.1	3.35	4.75	5.5	M5	6	8.9	4	4	15	15	7.5	5.3	4.5	60	20	M4x16	10.59	16.19	0.11	0.09	0.09	0.20	1.42									
HW20CA	30	4.3	21.5	63	53	5	40	50.5	76.5		5	6	12	M6	8	10	6	6	20	17.5	9.5	8.5	6	60	20	M5x16	17.2	25.6	0.25	0.18	0.18	0.33						2.2			
HW20HA							65.2	91.2																																	
HW25CA	36	5.6	23.5	70	57	6.5	45	58	82		5	6	12	M8	8	14	6	5.5	23	22	11	9	7	60	20	M6x20	25.11	36.42	0.41	0.32	0.32	0.53						3.25			
HW25HA							78.6	102.6																																	
HW30CA	42	6	31	90	72	9	52	70	98		6.5	5.5	12	M10	8.5	16	7	6	28	26	14	12	9	80	20	M8x25	34.93	49.58	0.58	0.5	0.5	0.90						4.49			
HW30HA							93	121																																	
HW35CA	48	7.4	33	100	82	9	62	80	112		5.5	6.5	12	M10	10	18	9	8	34	29	14	12	9	80	20	M8x25	48.5	57.6	1.08	0.78	0.78	1.50						6.36			
HW35HA							105.8	137.8																																	
HW45CA	60	9.5	37.5	120	100	10	80	97	137		4.8	8	13	M12	15	22	11	10	45	38	20	17	14	105	22.5	M12x35	75.26	100.2	1.8	1.35	1.35	2.75						10.45			
HW45HA							128.8	168.8																																	
HW55CA	70	13	43.5	140	116	12	95	117.7	161.7		6	11	13	M14	17.5	26.5	12	19	53	44	23	20	16	120	30	M14x45	112.33	145.64	3.59	2.5	2.5	4.20						15.12			
HW55HA							155.8	199.8																																	
HW65CA	90	15	53.5	170	142	14	110	144.2	194.2		6	14	13	M16	25	37.5	15	15	63	53	26	22	18	150	35	M16x50	160.22	210.37	6.45	4.18	4.18	9.25						21.25			
HW65HA							203.6	253.6																																	

Note : 1 kgf = 9.81 N

(4) HW-CB / HW-HB

(5) HW-CC / HW-HC

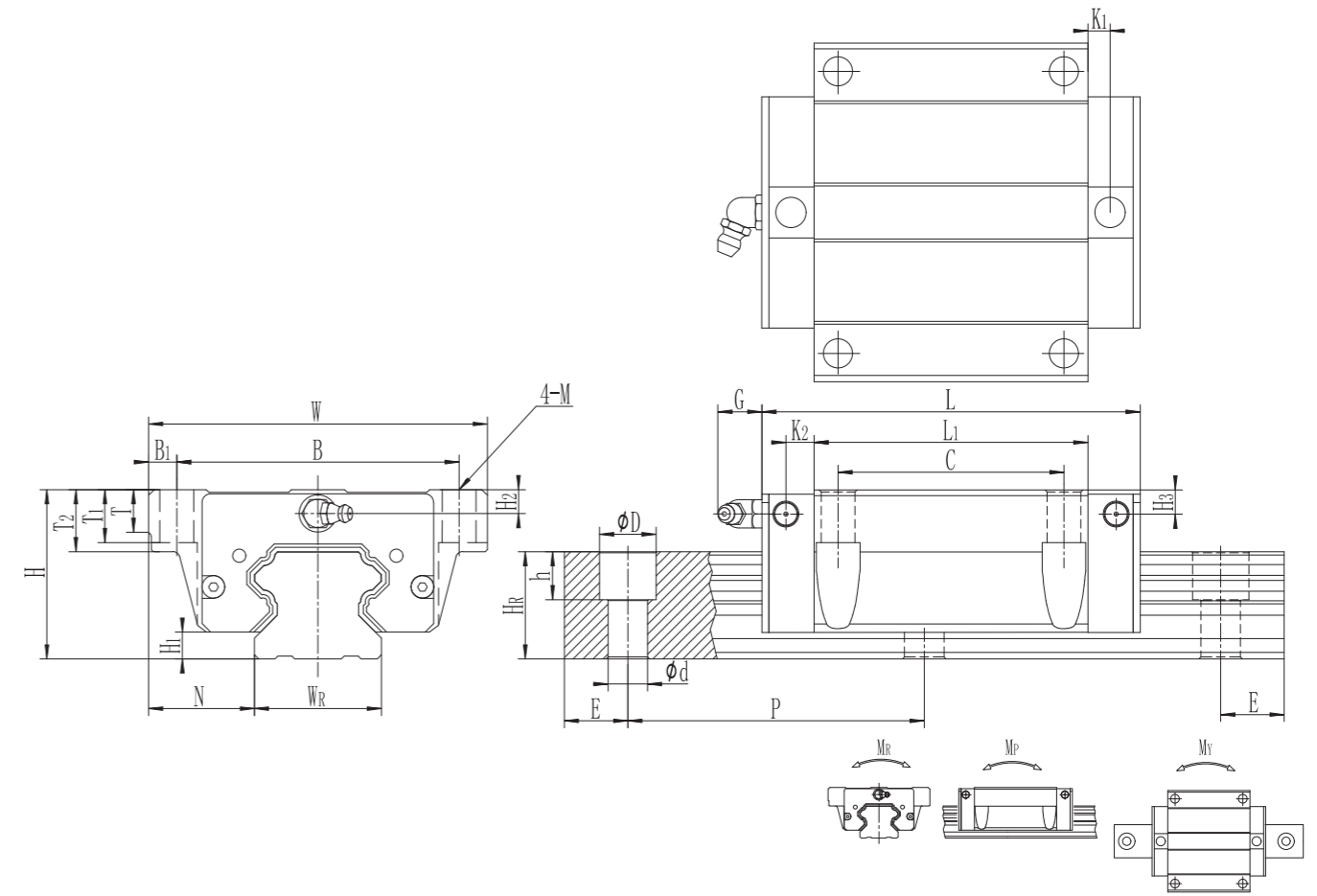
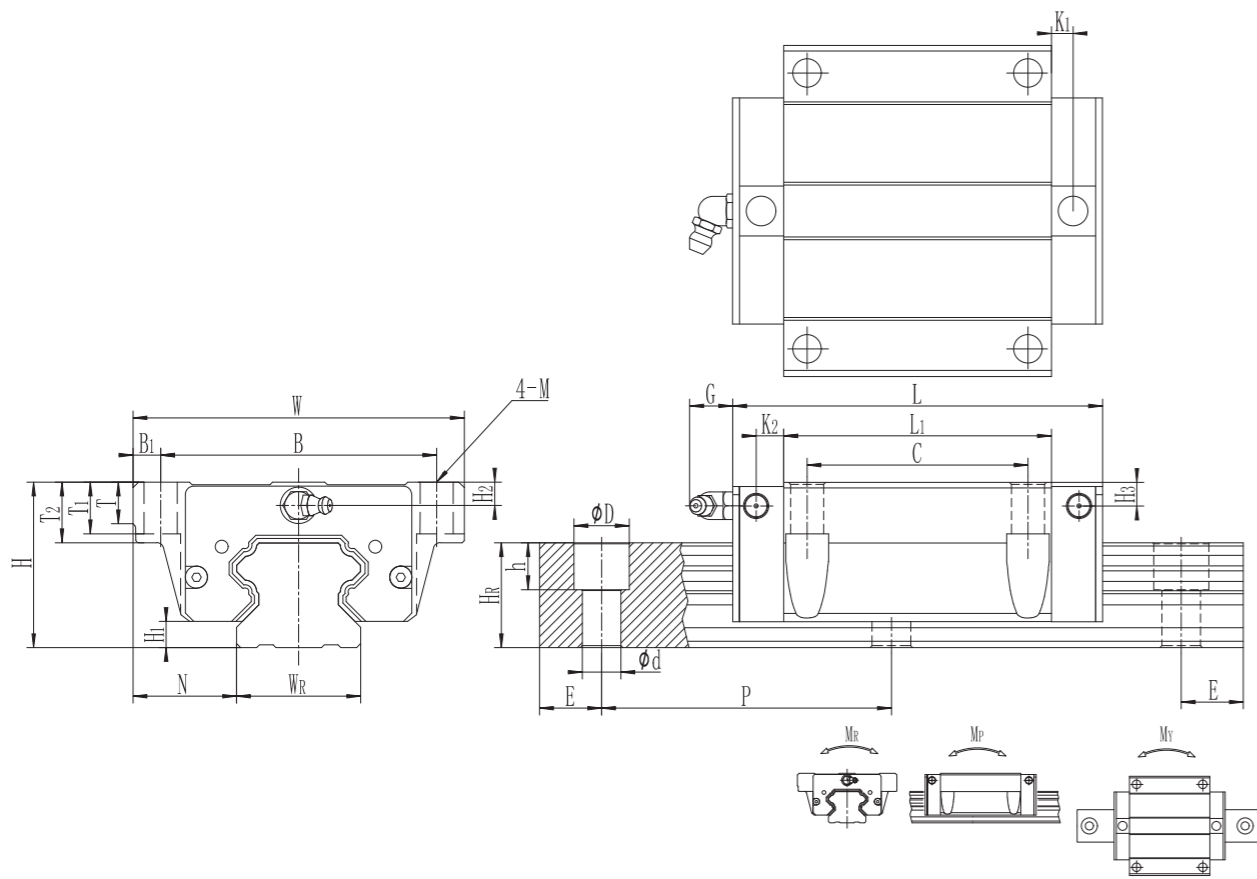

Model No.	Dimensions of Assembly (mm)			Dimensions of Block(mm)														Dimensions of Rail (mm)					Mounting Bolt for Rail (mm)	Basic Dynamic Load Rating C(KN)	Basic Static Load Rating C0(KN)	Static Rated Moment			Weight							
	H	H1	N	W	B	B1	C	L1	L	K1	K2	G	M	T	T1	T2	H2	H3	WR	Hr	D	h				d	P	E	MR	MP	MY	Block kg	Rail kg/m			
	HW15CB	24	4.4	16	47	38	4.5	30	39.5	61.1	3.35	4.75	5.5	φ4.5	6	8.9	7	4	4	15	15	7.5				5.3	4.5	60	20	M4×16	10.59	16.19	0.11	0.09	0.09	0.20
HW20CB	30	4.3	21.5	63	53	5	40	50.5	76.5	5	6	12	φ6	8	10	9	6	6	20	17.5	9.5	8.5	6	60	20	M5×16	17.2	25.6	0.25	0.18	0.18	0.33	2.2			
HW20HB								65.2	91.2																											
HW25CB	36	5.6	23.5	70	57	6.5	45	58	82	5	6	12	φ7	8	14	10	6	5.5	23	22	11	9	7	60	20	M6×20	25.11	36.42	0.41	0.32	0.32	0.53	3.25			
HW25HB								78.6	102.6																											
HW30CB	42	6	31	90	72	9	52	70	98	6.5	5.5	12	φ9	8.5	16	10	7	6	28	26	14	12	9	80	20	M8×25	34.93	49.58	0.58	0.5	0.5	0.90	4.49			
HW30HB								93	121																											
HW35CB	48	7.4	33	100	82	9	62	80	112	5.5	6.5	12	φ9	10	18	13	9	8	34	29	14	12	9	80	20	M8×25	48.5	57.6	1.08	0.78	0.78	1.50	6.36			
HW35HB								105.8	137.8																											
HW45CB	60	9.5	37.5	120	100	10	80	97	137	4.8	8	13	φ11	15	22	15	11	10	45	38	20	17	14	105	22.5	M12×35	75.26	100.2	1.8	1.35	1.35	2.75	10.45			
HW45HB								128.8	168.8																											
HW55CB	70	13	43.5	140	116	12	95	117.7	161.7	6	11	13	φ14	17.5	26.5	17	12	19	53	44	23	20	16	120	30	M14×45	112.33	145.64	3.59	2.5	2.5	4.20	15.12			
HW55HB								155.8	199.8																											
HW65CB	90	15	53.5	170	142	14	110	144.2	194.2	6	14	13	φ16	25	37.5	23	15	15	63	53	26	22	18	150	35	M16×50	160.22	210.37	6.45	4.18	4.18	9.25	21.25			
HW65HB								203.6	253.6																											

Note : 1 kgf = 9.81 N

Model No.	Dimensions of Assembly (mm)			Dimensions of Block(mm)														Dimensions of Rail (mm)					Mounting Bolt for Rail (mm)	Basic Dynamic Load Rating C(KN)	Basic Static Load Rating C0(KN)	Static Rated Moment			Weight								
	H	H1	N	W	B	B1	C	L1	L	K1	K2	G	M	T	T1	T2	H2	H3	WR	Hr	D	h				d	P	E	MR	MP	MY	Block kg	Rail kg/m				
	HW15CC	24	4.4	16	47	38	4.5	30	39.5	61.1	3.35	4.75	5	M5	6	7	8.9	4	4	15	15	7.5				5.3	4.5	60	20	M4×16	10.59	16.19	0.11	0.09	0.09	0.20	1.42
HW20CC	30	4.3	21.5	63	53	5	40	50.5	76.5	5	6	12	M6	8	9	10	6	6	20	17.5	9.5	8.5	6	60	20	M5×16	17.2	25.6	0.25	0.18	0.18	0.33	2.2				
HW20HC								65.2	91.2																												
HW25CC	36	5.6	23.5	70	57	6.5	45	58	82	5	6	12	M8	8	10	14	6	5.5	23	22	11	9	7	60	20	M6×20	25.11	36.42	0.41	0.32	0.32	0.53	3.25				
HW25HC								78.6	102.6																												
HW30CC	42	6	31	90	72	9	52	70	98	6.5	5.5	12	M10	8.5	10	16	7	6	28	26	14	12	9	80	20	M8×25	34.93	49.58	0.58	0.5	0.5	0.90	4.49				
HW30HC								93	121																												
HW35CC	48	7.4	33	100	82	9	62	80	112	5.5	6.5	12	M10	10	13	18	9	8	34	29	14	12	9	80	20	M8×25	48.5	57.6	1.08	0.78	0.78	1.50	6.36				
HW35HC								105.8	137.8																												
HW45CC	60	9.5	37.5	120	100	10	80	97	137	4.8	8	13	M12	15	15	22	11	10	45	38	20	17	14	105	22.5	M12×35	75.26	100.2	1.8	1.35	1.35	2.75	10.45				
HW45HC								128.8	168.8																												
HW55CC	70	13	43.5	140	116	12	95	117.7	161.7	6	11	13	M14	17.5	17	26.5	12	19	53	44	23	20	16	120	30	M14×45	112.33	145.64	3.59	2.5	2.5	4.20	15.12				
HW55HC								155.8	199.8																												
HW65CC	90	15	53.5	170	142	14	110	144.2	194.2	6	14	13	M16	25	23	37.5	15	15	63	53	26	22	18	150	35	M16×50	160.22	210.37	6.45	4.18	4.18	9.25	21.25				
HW65HC								203.6	253.6																												

Note : 1 kgf = 9.81 N

(6) Dimensions for HR-T (Rail Mounting from Bottom)

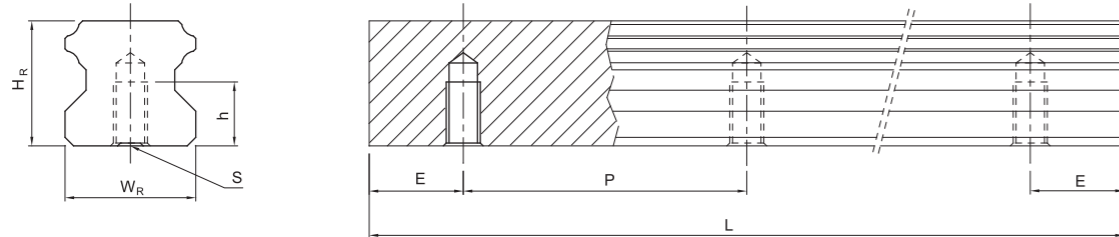

Model No.	Dimensions of Rail (mm)						Weight (kg/m)
	W _R	H _R	S	h	P	E	
HR15T	15	15	M5 x 0.8P	8	60	20	1.48
HR20T	20	17.5	M6 x 1P	10	60	20	2.29
HR25T	23	22	M6 x 1P	12	60	20	3.35
HR30T	28	26	M8 x 1.25P	15	80	20	4.67
HR35T	34	29	M8x1.25P	17	80	20	6.51
HR45T	45	38	M12 x 1.75P	24	105	22.5	10.87
HR55T	53	44	M14 x 2P	24	120	30	15.67
HR65T	63	53	M20 x 2.5P	30	150	35	21.73

2-2 E Series – Low Profile Ball Type Linear Guideway

2-2-1 Features of E Series

The design of the E series offers a low profile, high load capacity, and high rigidity. It also features an equal load rating in all four directions and self-aligning capability to absorb installation-error, allowing for higher accuracies. Additionally, the lower assembly height and the shorter length make the E series more suitable for high-speed, automation machines and applications where space is limited. The retainer is designed to hold the balls in the block even when it is removed from the rail.

2-2-2 Construction of E Series

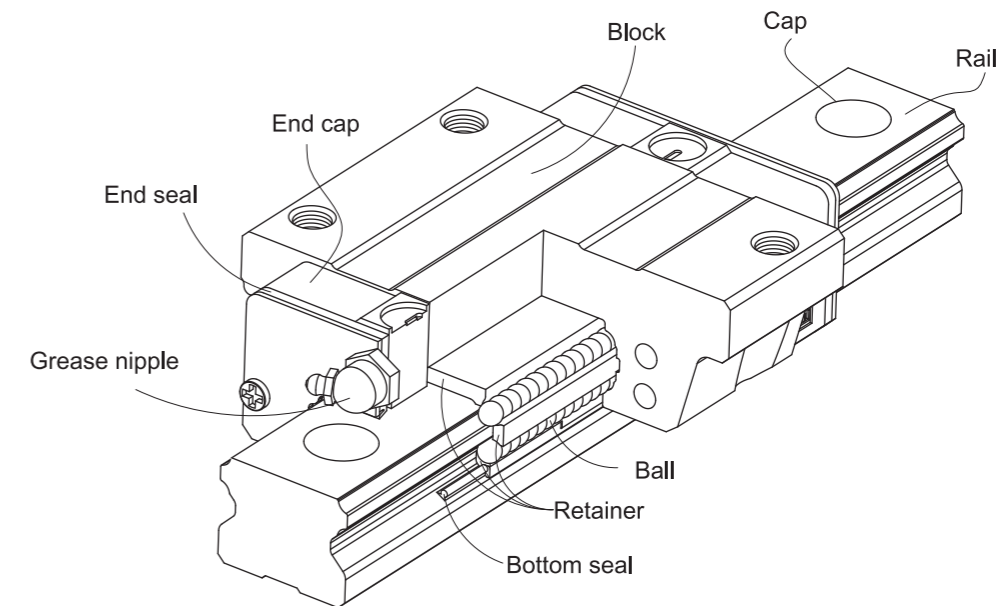

- Rolling circulation system: Block, rail, end cap and retainer
- Lubrication system: Grease nipple and piping Joint
- Dust protection system: End seal, bottom seal, cap and scraper

2-2-3 Model Number of E Series

E series linear guideways are classified into non-interchangeable and interchangeable types. The sizes of these two types are the same as one another. The main difference is that the interchangeable type of blocks and rails can be freely exchanged and they can maintain P-class accuracy. Because of strict dimensional control, the interchangeable type linear guideways are a wise choice for customers when rails do not need to be matched for an axis. The model number of the E series identifies the size, type, accuracy class, preload class, etc.

(1) Non-interchangeable type

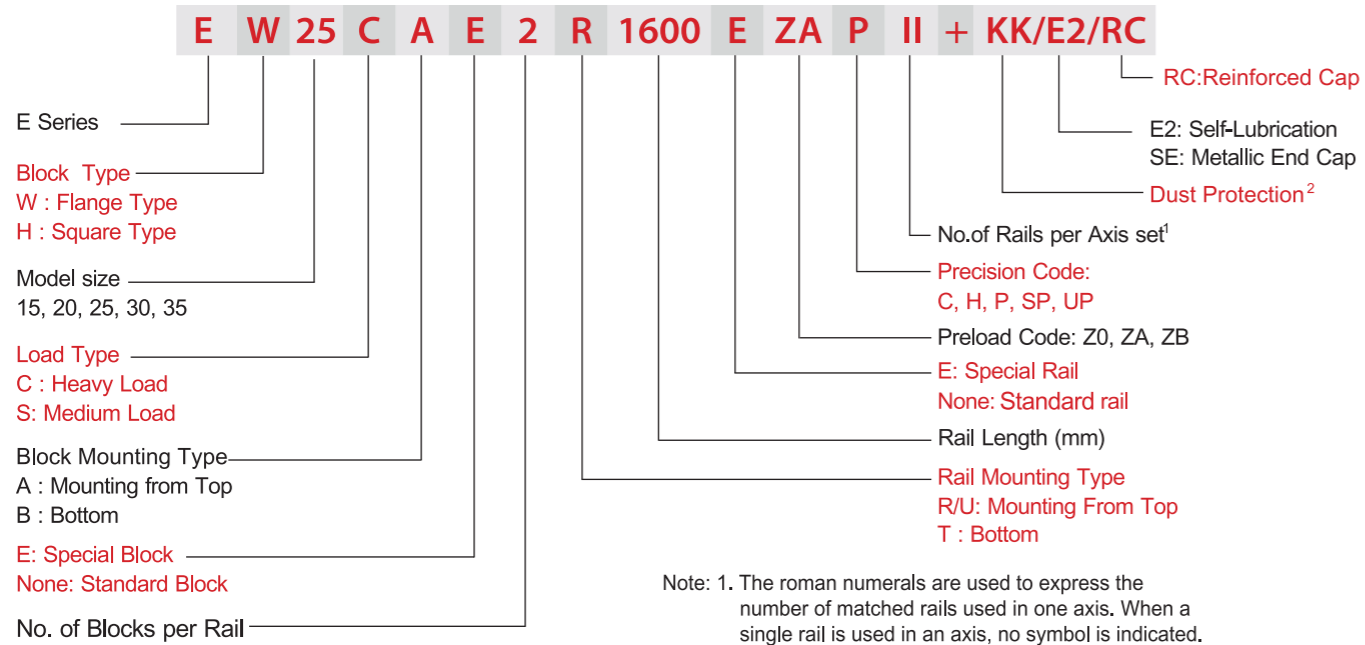

(2) Interchangeable type

□ Model Number of E Block

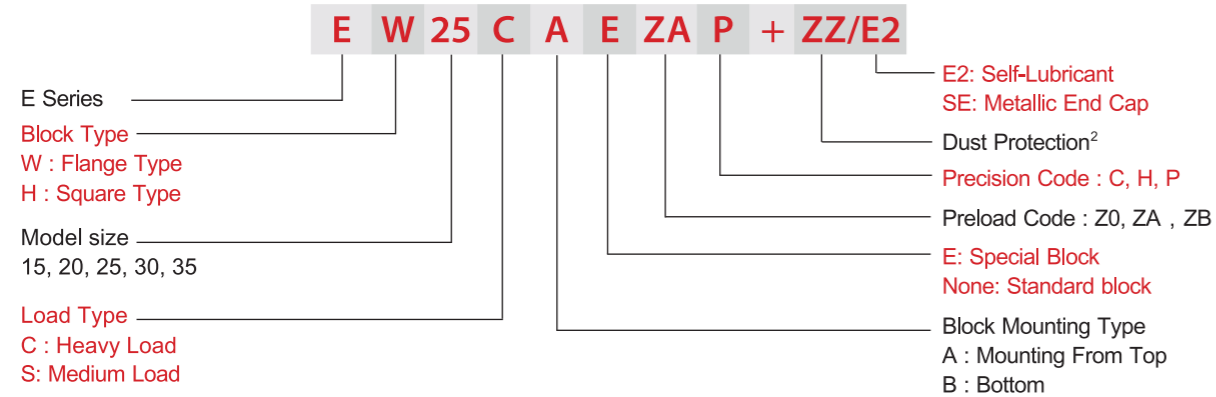

□ Model Number of E Rail

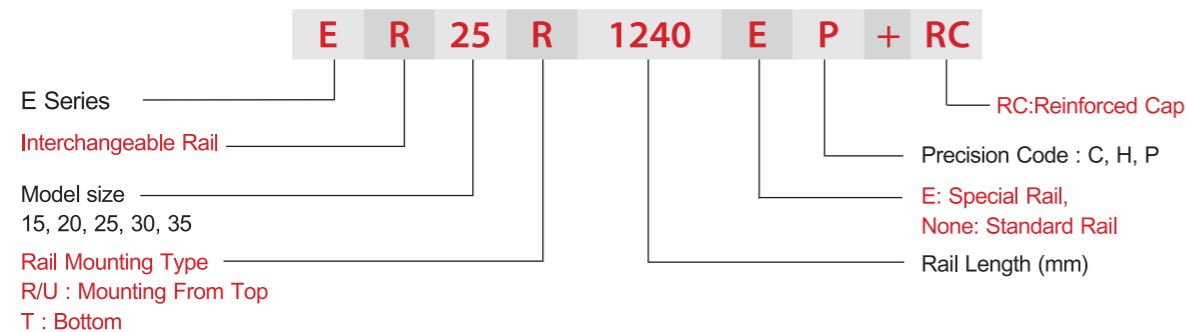

2-2-4 Types

(1) Block types

LIMON offers two types of linear guideways, flange and square types.

Table 2-2-1 Block Types

Type	Model	Shape	Height (mm)	Rail Length (mm)	Main Applications
Square	EH-SA EH-CA		24	100	<ul style="list-style-type: none"> Automation devices High-speed transportation equipment Precision measuring equipment Semiconductor manufacturing equipment
			48	4000	
Flange	EW-SA EW-CA		24	100	
			48	4000	
Flange	EW-SB EW-CB		24	100	
			48	4000	

(2) Rail types

Besides the standard top mounting type, LIMON also offers bottom mounting type rails.

Table 2-2-2 Rail Types

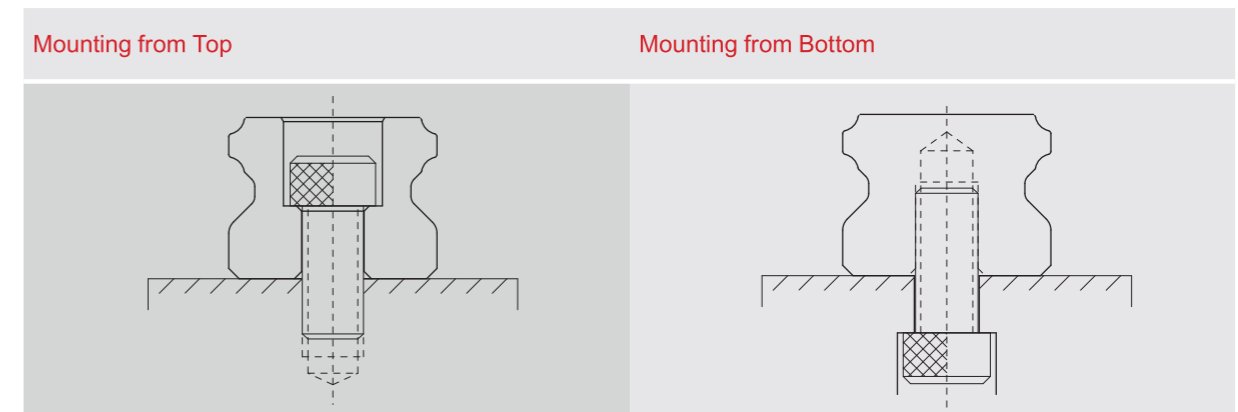

2-2-5 Accuracy

The accuracy of the E series can be classified into 5 classes: normal(C), high(H), precision(P), super precision(SP), and ultra precision(UP). Choose the class by referencing the accuracy of selected equipment.

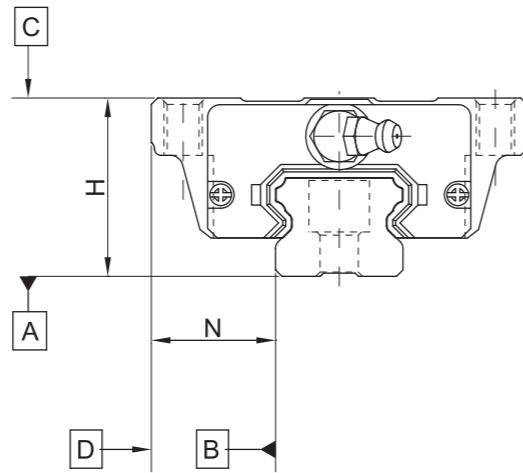

(1) Accuracy of non-interchangeable guideways

Table 2-2-3 Accuracy Standards

Unit: mm

Item	E - 15, 20				
	Normal (C)	High (H)	Precision (P)	Super Precision (SP)	Ultra Precision (UP)
Dimensional tolerance of height H	± 0.1	± 0.03	0 -0.03	0 -0.015	0 -0.008
Dimensional tolerance of width N	± 0.1	± 0.03	0 -0.03	0 -0.015	0 -0.008
Variation of height H	0.02	0.01	0.006	0.004	0.003
Variation of width N	0.02	0.01	0.006	0.004	0.003
Running parallelism of block surface C to surface A	See Table 2-2-7				
Running parallelism of block surface D to surface B	See Table 2-2-7				

Table 2-2-4 Accuracy Standards

Unit: mm

Item	E - 25, 30, 35				
	Normal (C)	High (H)	Precision (P)	Super Precision (SP)	Ultra Precision (UP)
Dimensional tolerance of height H	± 0.1	± 0.04	0 -0.04	0 -0.02	0 -0.01
Dimensional tolerance of width N	± 0.1	± 0.04	0 -0.04	0 -0.02	0 -0.01
Variation of height H	0.02	0.015	0.007	0.005	0.003
Variation of width N	0.03	0.015	0.007	0.005	0.003
Running parallelism of block surface C to surface A	See Table 2-2-7				
Running parallelism of block surface D to surface B	See Table 2-2-7				

(2) Accuracy of interchangeable guideways

Table 2-2-5 Accuracy Standards

Unit: mm

Item	E - 15, 20		
	Normal (C)	High (H)	Precision (P)
Dimensional tolerance of height H	± 0.1	± 0.03	± 0.015
Dimensional tolerance of width N	± 0.1	± 0.03	± 0.015
Variation of height H	0.02	0.01	0.006
Variation of width N	0.02	0.01	0.006
Running parallelism of block surface C to surface A	See Table 2-2-7		
Running parallelism of block surface D to surface B	See Table 2-2-7		

Table 2-2-6 Accuracy Standards

Unit: mm

Item	E - 25, 30, 35		
	Normal (C)	High (H)	Precision (P)
Dimensional tolerance of height H	± 0.1	± 0.04	± 0.02
Dimensional tolerance of width N	± 0.1	± 0.04	± 0.02
Variation of height H	0.02	0.015	0.007
Variation of width N	0.03	0.015	0.007
Running parallelism of block surface C to surface A	See Table 2-2-7		
Running parallelism of block surface D to surface B	See Table 2-2-7		

(3) Accuracy of running parallelism

Table 2-2-7 Accuracy of Running Parallelism

Rail Length (mm)	Accuracy (μm)				
	C	H	P	SP	UP
~ 100	12	7	3	2	2
100 ~ 200	14	9	4	2	2
200 ~ 300	15	10	5	3	2
300 ~ 500	17	12	6	3	2
500 ~ 700	20	13	7	4	2
700 ~ 900	22	15	8	5	3
900 ~ 1,100	24	16	9	6	3
1,100 ~ 1,500	26	18	11	7	4
1,500 ~ 1,900	28	20	13	8	4
1,900 ~ 2,500	31	22	15	10	5
2,500 ~ 3,100	33	25	18	11	6
3,100 ~ 3,600	36	27	20	14	7
3,600 ~ 4,000	37	28	21	15	7

2-2-6 Preload

(1) Definition

A preload can be applied to each guideway. Generally, a linear motion guideway has a negative clearance between the groove and balls in order to improve stiffness and maintain high precision. The figure shows that adding a preload can improve stiffness of the linear guideway. A preload no greater than ZA would be recommended for model sizes smaller than E20. This will avoid an over-loaded condition that would affect guideway life.

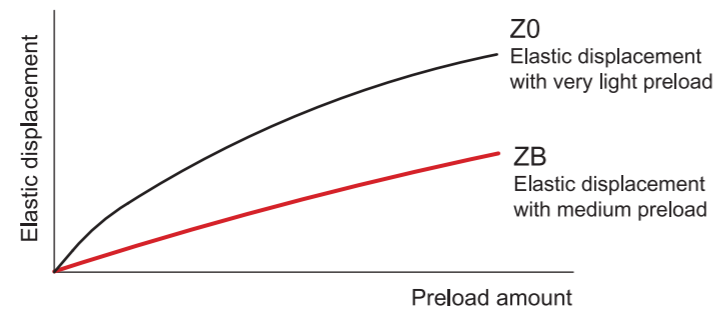

(2) Preload classes

LIMON offers three standard preloads for various applications and conditions.

Table 2-2-8 Preload Classes

Class	Code	Preload	Condition
Very Light Preload	Z0	0~ 0.02C	Certain load direction, low impact, low precision required
Light Preload	ZA	0.03C~0.05C	low load and high precision required
Medium Preload	ZB	0.06C~ 0.08C	High rigidity required, with vibration and impact

Class	Interchangeable Guideway	Non-Interchangeable Guideway
Preload classes	Z0, ZA	Z0, ZA, ZB

Note: The "C" in the preload column denotes basic dynamic load rating.

2-2-7 Lubrication

(1) Grease

□ Grease nipple

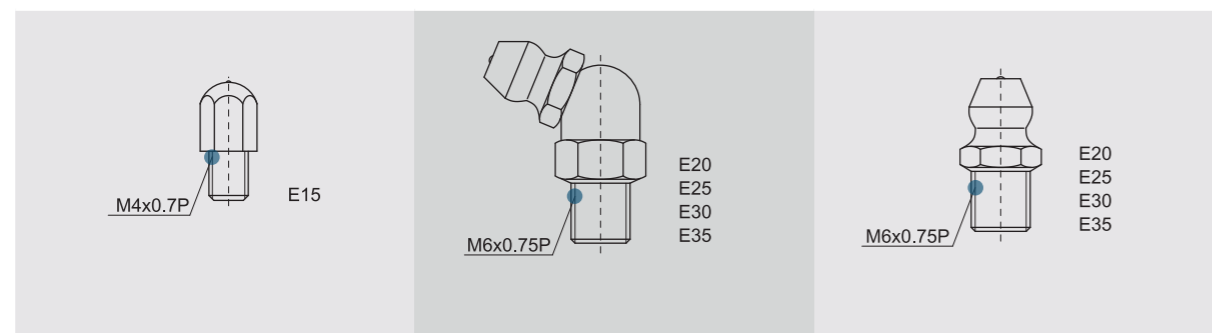

□ Mounting location

The standard location of the grease fitting is at both ends of the block, the nipple may be mounted in the side or top of the block. For lateral installation, we recommend that the nipple be mounted to the non-reference side, otherwise please contact us. When lubricating from above, in the recess for the O-ring, a smaller, preformed recess can be found. Preheat the 0.8 mm diameter metal tip. Carefully open the small recess with the metal tip and pierce through it. Insert a round sealing ring into the recess. (The round sealing ring is not supplied with the block) Do not open the small recess with a drill bit this may introduce the danger of contamination. It is possible to carry out the lubrication by using the oil-piping joint.

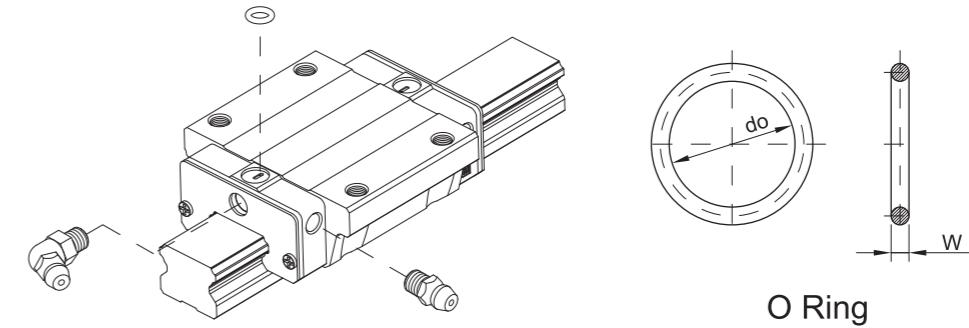

Table 2-2-9 O-Ring size and max. permissible depth for piercing

Size	O-Ring		Lube hole at top: max. permissible depth for piercing
	do(mm)	W (mm)	T _{max} (mm)
E15	2.5 ± 0.15	1.5 ± 0.15	6.9
E20	4.5 ± 0.15	1.5 ± 0.15	8.4
E25	4.5 ± 0.15	1.5 ± 0.15	10.4
E30	4.5 ± 0.15	1.5 ± 0.15	10.4
E35	4.5 ± 0.15	1.5 ± 0.15	10.8

□ The oil amount for a block filled with grease

Table 2-2-10 The oil amount for a block filled with grease

Size	Medium Load (cm ³)	Heavy Load (cm ³)
E15	0.8	1.4
E20	1.5	2.4
E25	2.8	4.6
E30	3.7	6.3
E35	5.6	6.6

Frequency of replenishment

Check the grease every 100 km, or every 3-6 months.

2-2-8 Dust Proof Accessories

(1) Codes of accessories

If the following accessories is needed, please indicate the code followed by the model number.

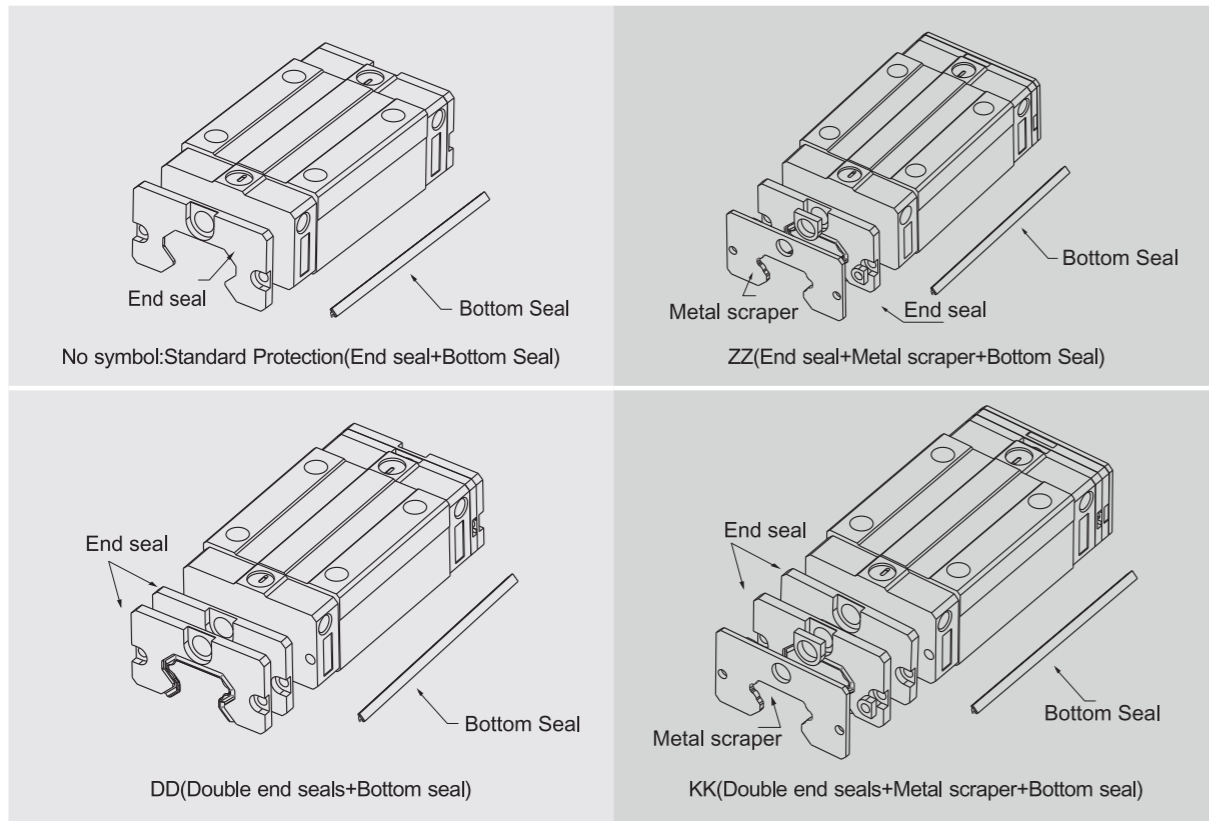

(2) End seal and bottom seal

Protects against contaminants entering the block. Reduces potential for groove damage resulting in a reduction of life ratings.

(3) Double seals

Removing foreign matters from the rail to prevent contaminants from entering the block.

Table 2-2-11 Dimensions of end seal

Size	Thickness (t1) (mm)
E15 ES	2
E20 ES	2
E25 ES	2
E30 ES	2
E35 ES	2

(4) Scraper

Clears larger contaminants, such as weld spatter and metal cuttings, from the rail. Metal scraper protects end seals from excessive damage.

Table 2-2-12 Dimensions of Scraper

Size	Thickness (t2) (mm)
E 15 SC	0.8
E 20 SC	0.8
E 25 SC	1
E 30 SC	1
E 35 SC	1.5

(5) Bolt caps for rail mounting holes

Rail mounting hole caps prevent foreign matter from accumulating in the mounting holes. Caps are included with the rail package.

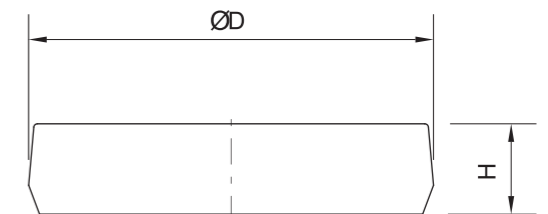

Table 2-2-13 Dimensions of Bolt Caps for Rail Mounting Holes

Rail size	Bolt size	Diameter(D) (mm)	Thickness(H) (mm)
ER15R	M3	6.15	1.2
ER20R	M5	9.65	2.5
ER25R	M6	11.15	2.5
ER30R	M6	11.15	2.5
ER35R	M8	14.20	3.5
ER15U	M4	7.65	1.1
ER30U	M8	14.20	3.5

(6) Dimensions of block equipped with the dustproof parts

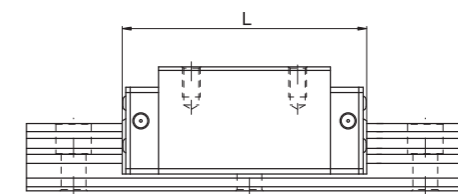

Table 2-2-14 Overall block length

Unit: mm

Size	Overall block length (L)			
	SS	ZZ	DD	KK
E15S	41.1	43.7	46.1	48.7
E15C	57.8	60.4	62.8	65.4
E20S	51.2	53.8	56.4	59
E20C	70.3	72.9	75.5	78.1
E25S	59.7	62.3	65.7	68.3
E25C	85.2	87.8	91.2	93.8
E30S	71.9	74.5	78.1	80.7
E30C	100.4	103	106.6	109.2
E35S	76	79	80	83
E35C	108	111	112	115

2-2-9 Friction

The maximum value of resistance per end seal are as shown in the table.

Table 2-2-15 Seal Resistance

Size	Resistance N (kgf)
E15	1 (0.1)
E20	1.2 (0.17)
E25	2 (0.2)
E30	2.6 (0.27)
E35	3.5 (0.36)

Note: 1kgf=9.81N

2-2-10 The Accuracy Tolerance of Mounting Surface

Because of the circular-arc contact design, the E linear guideway can withstand surface-error installation and deliver smooth linear motion. When the mounting surface meets the accuracy requirements of the installation, the high accuracy and rigidity of the guideway will be obtained without any difficulty. For faster installation and smoother movement, LIMON offers a preload with normal clearance because of its ability to absorb higher deviations in mounting surface inaccuracies.

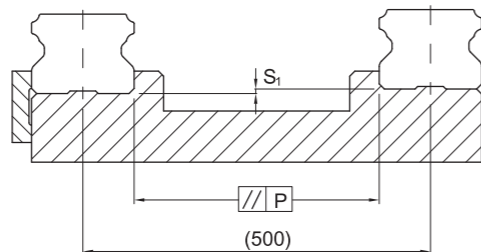

Table 2-2-16 Max. Parallelism Tolerance (P)

Size	Preload classes		
	Z0	ZA	ZB
E15	25	18	-
E20	25	20	18
E25	30	22	20
E30	40	30	27
E35	50	35	30

unit: μm

Table 2-2-17 Max. Tolerance of Reference Surface Height (S_1)

Size	Preload classes		
	Z0	ZA	ZB
E15	130	85	-
E20	130	85	50
E25	130	85	70
E30	170	110	90
E35	210	150	120

unit: μm

2-2-11 Cautions for Installation

(1) Shoulder heights and chamfers

Improper shoulder heights and chamfers of mounting surfaces will cause deviations in accuracy and rail or block interference with the chamfered part.

When recommended shoulder heights and chamfers are used, problems with installation accuracy should be eliminated.

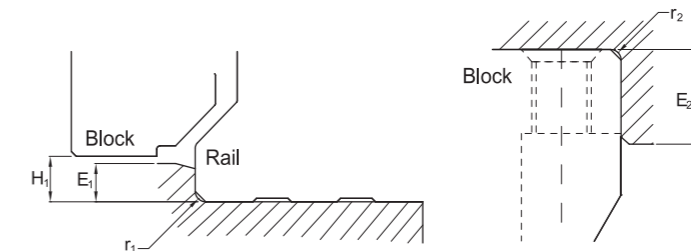

Table 2-2-18 Shoulder Heights and Chamfers

unit: mm

Size	Max. radius of fillets r_1 (mm)	Max. radius of fillets r_2 (mm)	Shoulder height of the rail E_1 (mm)	Shoulder height of the block E_2 (mm)	Clearance under block H_1 (mm)
E15	0.5	0.5	2.7	5.0	4.5
E20	0.5	0.5	5.0	7.0	6.0
E25	1.0	1.0	5.0	7.5	7.0
E30	1.0	1.0	7.0	7.0	10.0
E35	1.0	1.0	7.5	9.5	11.0

(2) Tightening Torque of Bolts for Installation

Improperly tightened mounting bolts will seriously affect the accuracy of linear guide installations. The following tightening torques for different sizes of bolts are recommended.

Table 2-2-19 Tightening Torque

Size	Bolt size	Torque N-cm(kgf-cm)		
		Iron	Casting	Aluminum
E15	M3×0.5P×16L	186 (19)	127 (13)	98 (10)
E20	M5×0.8P×16L	883 (90)	588 (60)	441 (45)
E25	M6×1P×20L	1373 (140)	921 (94)	686 (70)
E30	M6×1P×25L	1373 (140)	921 (94)	686 (70)
E35	M8×1.25P×25L	3041 (310)	2010 (205)	1470 (150)

Note: 1 kgf = 9.81 N

2-2-12 Dimensions for E Series

(1) EH-SA / EH-CA

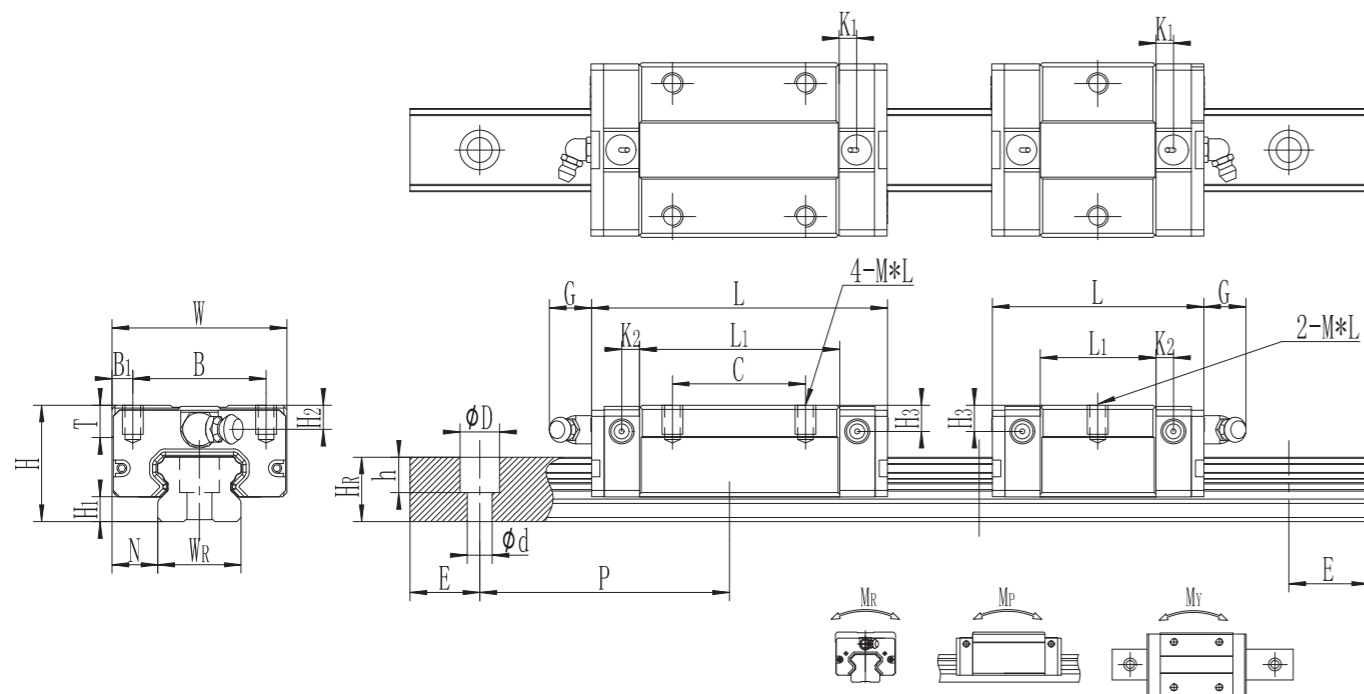

(2) EW-SA / EW-CA

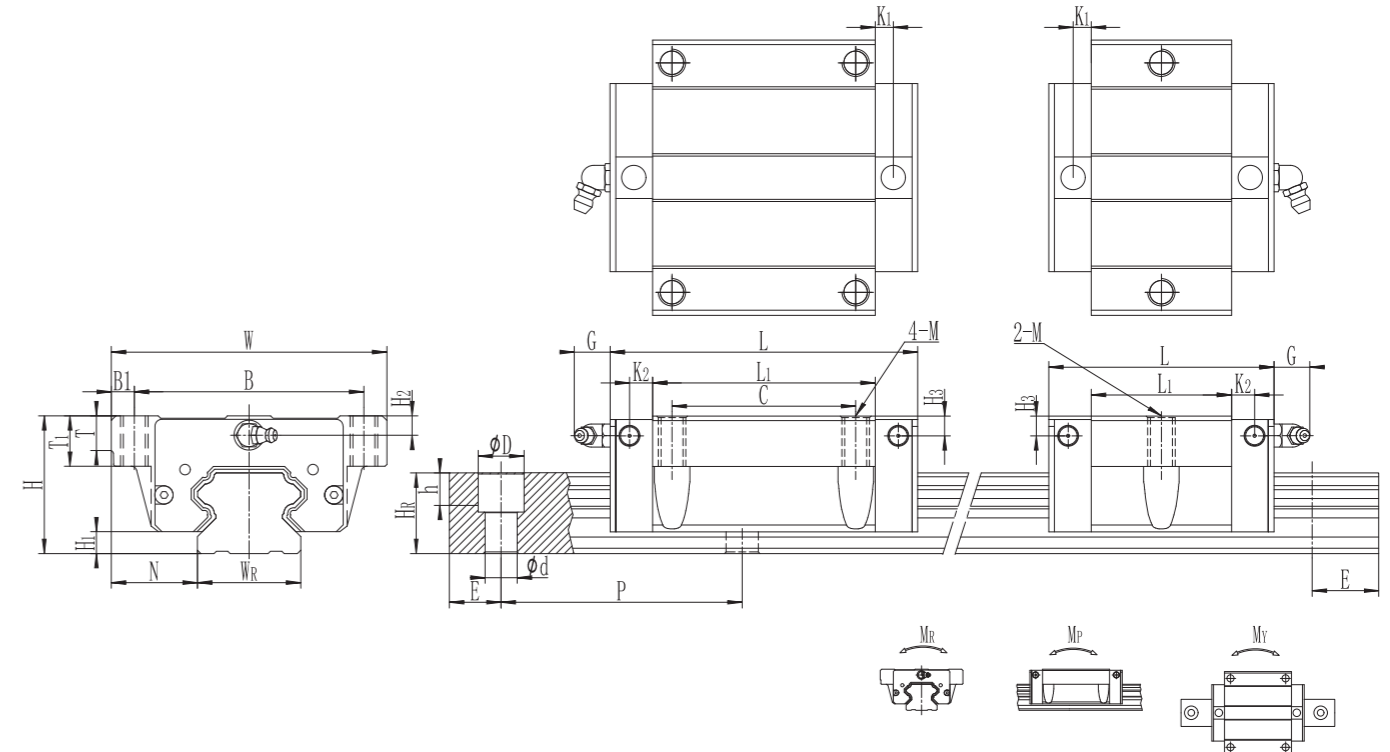

Linear Guideways

Ball Screw

Support

Linear Bushing

Model No.	Dimensions of Assembly (mm)		Dimensions of Block(mm)																Mounting Bolt for Rail (mm)	Basic Dynamic Load Rating C(KN)	Basic Static Load Rating C0(KN)	Static Rated Moment			Weight						
	H	H1	N	W	B	B1	C	L1	L	K1	K2	G	M*L	T	H2	H3	WR	Hr				D	h	d	P	E	Mr	Mp	My	Block kg	Rail kg/m
EH15SA	24	4.4	9.5	34	26	4	-	23.1	41.1	3.4	3.4	5.5	M4×6	6	5.8	5.8	15	12.5	6	4.5	3.5	60	20	M3×16	5.1	8.94	0.06	0.03	0.03	0.12	1.26
EH15CA	24	4.4	9.5	34	26	4	26	39.8	57.8	3.4	3.4	5.5	M4×6	6	5.8	5.8	15	12.5	7.5	5.3	4.5	60	20	M4×16	7.21	14.25	0.11	0.09	0.09	0.17	1.26
EH20SA	28	6	11	42	32	5	-	29	50	4.2	4.2	12	M5×7	7.5	5.8	6.3	20	15.5	9.5	8.5	6	60	20	M5×16	6.54	10.75	0.1	0.50	0.50	0.16	2.09
EH20CA	28	6	11	42	32	5	32	48.1	69.1	4.2	4.2	12	M5×7	7.5	5.8	6.3	20	15.5	9.5	8.5	6	60	20	M5×16	9.81	18.32	0.19	0.10	0.10	0.28	2.09
EH25SA	33	6.2	12.5	48	35	6.5	-	35.5	59.7	5	5	12	M6×9	8	7.4	7.4	23	18	11	9	7	60	20	M6×20	10.2	17.6	0.2	0.09	0.09	0.26	2.69
EH25CA	33	6.2	12.5	48	35	6.5	35	59	85	5	5	12	M6×9	8	7.4	7.4	23	18	11	9	7	60	20	M6×20	15.1	30.12	0.35	0.3	0.3	0.42	2.69
EH30SA	42	10	16	60	40	10	-	41.5	71.5	6	6	12	M8×12	9	9	9	28	23	11	9	7	80	20	M6×25	15.32	26.28	0.3	0.15	0.15	0.46	4.26
EH30CA	42	10	16	60	40	10	40	70	100	6	6	12	M8×12	9	9	9	28	23	14	12	9	80	20	M8×25	20.12	45.33	0.5	0.42	0.42	0.77	4.26
EH30SA	42	10	16	60	40	10	-	41.5	71.5	6	6	12	M8×12	9	9	9	28	23	14	12	9	80	20	M8×25	15.32	26.28	0.3	0.15	0.15	0.46	4.26
EH30CA	42	10	16	60	40	10	40	70	100	6	6	12	M8×12	9	9	9	28	23	14	12	9	80	20	M8×25	20.12	45.33	0.5	0.42	0.42	0.77	4.26
EH35SA	48	11	18	70	50	10	-	45	75	7	7	12	M8×12	10	8.5	8.5	34	27.5	14	12	9	80	20	M8×25	20.65	35.58	0.46	0.2	0.2	0.75	6.11
EH35CA	48	11	18	70	50	10	50	78	108	7	7	12	M8×12	10	8.5	8.5	34	27.5	14	12	9	80	20	M8×25	30.94	61.83	0.8	0.51	0.51	1.12	6.11

Note : 1 kgf = 9.81 N

Model with "*" means guide rail with new installation hole, pls not the requirement when placing the order.

Model No.	Dimensions of Assembly (mm)		Dimensions of Block(mm)																Mounting Bolt for Rail (mm)	Basic Dynamic Load Rating C(KN)	Basic Static Load Rating C0(KN)	Static Rated Moment			Weight							
	H	H1	N	W	B	B1	C	L1	L	K1	K2	G	M	T	T1	H2	H3	WR				Hr	D	h	d	P	E	Mr	Mp	My	Block kg	Rail kg/m
EW15SA	24	4.4	18.5	52	41	5.5	-	23.1	41.1	3.4	3.4	5.5	M5	5	7.8	5.8	5.8	15	12.5	6	4.5	3.5	60	20	M3×16	5.1	8.94	0.06	0.03	0.03	0.12	1.26
EW15CA	24	4.4	18.5	52	41	5.5	26	39.8	57.8	3.4	3.4	5.5	M5	5	7.8	5.8	5.8	15	12.5	7.5	5.3	4.5	60	20	M4×16	7.21	14.25	0.11	0.09	0.09	0.17	1.26
EW15SA	24	4.4	18.5	52	41	5.5	-	23.1	41.1	3.4	3.4	5.5	M5	5	7.8	5.8	5.8	15	12.5	7.5	5.3	4.5	60	20	M4×16	5.1	8.94	0.06	0.03	0.03	0.12	1.26
EW15CA	24	4.4	18.5	52	41	5.5	26	39.8	57.8	3.4	3.4	5.5	M5	5	7.8	5.8	5.8	15	12.5	7.5	5.3	4.5	60	20	M4×16	7.21	14.25	0.11	0.09	0.09	0.17	1.26
EW20SA	28	6	19.5	59	49	5	-	29	50	4.2	4.2	12	M6	7	9	5.8	6.3	20	15.5	9.5	8.5	6	60	20	M5×16	6.54	10.75	0.1	0.50	0.50	0.16	2.09
EW20CA	28	6	19.5	59	49	5	32	48.1	69.1	4.2	4.2	12	M6	7	9	5.8	6.3	20	15.5	9.5	8.5	6	60	20	M5×16	9.81	18.32	0.19	0.10	0.10	0.28	2.09
EW25SA	33	6.2	25	73	60	6.5	-	35.5	59.7	5	5	12	M8	7.5	10	7.4	7.4	23	18	11	9	7	60	20	M6×20	10.2	17.6	0.2	0.09	0.09	0.26	2.69
EW25CA	33	6.2	25	73	60	6.5	35	59	85	5	5	12	M8	7.5	10	7.4	7.4	23	18	11	9	7	60	20	M6×20	15.1	30.12	0.35	0.3	0.3	0.42	2.69
EW30SA	42	10	31	90	72	9	-	41.5	71.5	6	6	12	M10	7	10	9	9	28	23	11	9	7	80	20	M6×25	15.32	26.28	0.3	0.15	0.15	0.46	4.26
EW30CA	42	10	31	90	72	9	40	70	100	6	6	12	M10	7	10	9	9	28	23	14	12	9	80	20	M8×25	20.12	45.33	0.5	0.42	0.42	0.77	4.26
EW30SA	42	10	31	90	72	9	-	41.5	71.5	6	6	12	M10	7	10	9	9	28	23	14	12	9	80	20	M8×25	15.32	26.28	0.3	0.15	0.15	0.46	4.26
EW30CA	42	10	31	90	72	9	40	70	100	6	6	12	M10	7	10	9	9	28	23	14	12	9	80	20	M8×25	20.12	45.33	0.5	0.42	0.42	0.77	4.26
EW35SA	48	11	33	100	82	9	-	45	75	7	7	12	M10	10	13	8.5	8.5	34	27.5	14	12	9	80	20	M8×25	20.65	35.58	0.46	0.2	0.2	0.75	6.11
EW35CA	48	11	33	100	82	9	50	78	108	7	7	12	M10	10	13	8.5	8.5	34	27.5	14	12	9	80	20	M8×25	30.94	61.83	0.8	0.51	0.51	1.12	6.11

Note : 1 kgf = 9.81 N

Model with "*" means guide rail with new installation hole, pls not the requirement when placing the order.

Linear Guideways

Ball Screw

Support

Linear Bushing

(3) EW-SB / EW-CB

(4)EW- SC/EW-CC

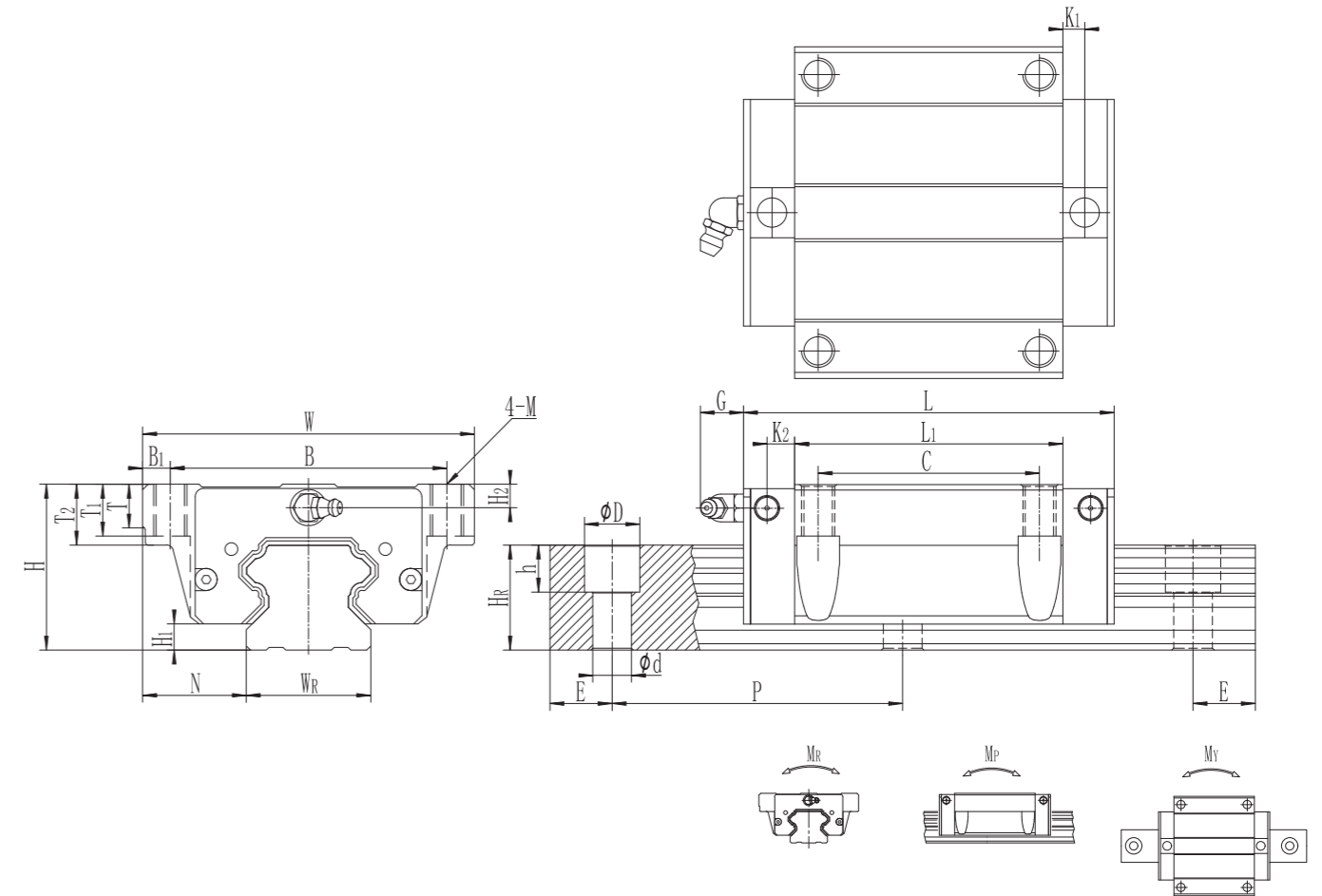
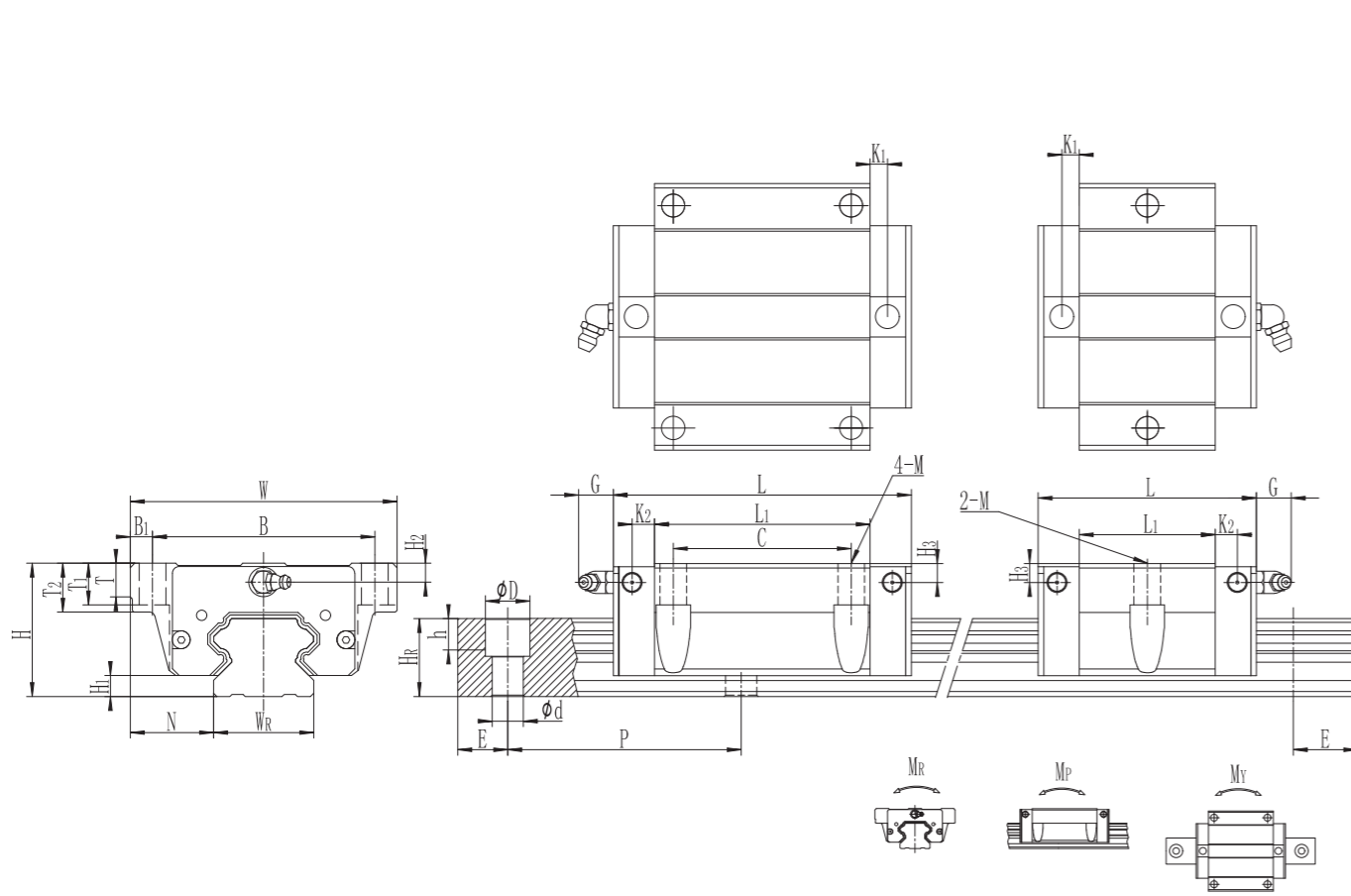

Linear Guideways

Ball Screw

Support

Linear Bushing

Linear Guideways

Ball Screw

Support

Linear Bushing

Model No.	Dimensions of Assembly (mm)		Dimensions of Block(mm)													Dimensions of Rail (mm)										Mounting Bolt for Rail (mm)	Basic Dynamic Load Rating C(KN)	Basic Static Load Rating C0(KN)	Static Rated Moment			Weight			
	H	H1	N	W	B	B1	C	L1	L	K1	K2	G	M	T	T1	T2	H2	H3	WR	HR	D	h	d	P	E				MR	MP	MY	Block kg	Rail kg/m		
EW15SB	24	4.4	18.5	52	41	5.5	-	23.1	41.1	3.4	3.4	5.5	φ4.5	5	7	7.8	5.8	5.8	15	12.5	6	4.5	3.5	60	20	M3×16	5.1	8.94	0.06	0.03	0.03	0.12	1.26		
EW15CB							26	39.8	57.8																										
EW15SB	24	4.4	18.5	52	41	5.5	-	23.1	41.1	3.4	3.4	5.5	φ4.5	5	7	7.8	5.8	5.8	15	12.5	7.5	5.3	4.5	60	20	M4×16	5.1	8.94	0.06	0.03	0.03	0.12	1.26		
EW15CB							26	39.8	57.8																										
EW20SB	28	6	19.5	59	49	5	-	29	50	4.2	4.2	12	φ5.5	7	7	9	5.8	6.3	20	15.5	9.5	8.5	6	60	20	M5×16	6.54	10.75	0.1	0.50	0.50	0.16	2.09		
EW20CB							32	48.1	69.1																										
EW25SB	33	6.2	25	73	60	6.5	-	35.5	59.7	5	5	12	φ7	7.5	10	10	7.4	7.4	23	18	11	9	7	60	20	M6×20	10.2	17.6	0.2	0.09	0.09	0.26	2.69		
EW25CB							35	59	85																										
EW30SB	42	10	31	90	72	9	-	41.5	71.5	6	6	12	φ9	7	10	10	9	9	28	23	11	9	7	80	20	M6×25	15.32	26.28	0.3	0.15	0.15	0.46	4.26		
EW30CB							40	70	100																										
EW30SB	42	10	31	90	72	9	-	41.5	71.5	6	6	12	φ9	7	10	10	9	9	28	23	14	12	9	80	20	M8×25	15.32	26.28	0.3	0.15	0.15	0.46	4.26		
EW30CB							40	70	100																										
EW35SB	48	11	33	100	82	9	-	45	75	7	7	12	φ9	10	13	13	8.5	8.5	34	27.5	14	12	9	80	20	M8×25	20.65	35.58	0.46	0.2	0.2	0.75	6.11		
EW35CB							50	78	108																										

Note : 1 kgf = 9.81 N
Model with "" means guide rail with new installation hole, pls not the requirement when placing the order.

Model No.	Dimensions of Assembly (mm)		Dimensions of Block(mm)													Dimensions of Rail (mm)										Mounting Bolt for Rail (mm)	Basic Dynamic Load Rating C(KN)	Basic Static Load Rating C0(KN)	Static Rated Moment			Weight				
	H	H1	N	W	B	B1	C	L1	L	K1	K2	G	M	T	T1	T2	H2	H3	WR	HR	D	h	d	P	E				MR	MP	MY	Block kg	Rail kg/m			
EW15SC	24	4.4	18.5	52	41	5.5	-	23.1	41.1	3.4	3.4	5.5	M5	5	7	7.8	5.8	5.8	15	12.5	6	4.5	3.5	60	20	M3×16	5.1	8.94	0.06	0.03	0.03	0.12	1.26			
EW15CC							26	39.8	57.8																											
EW15SC	24	4.4	18.5	52	41	5.5	-	23.1	41.1	3.4	3.4	5.5	M5	5	7	7.8	5.8	5.8	15	12.5	7.5	5.3	4.5	60	20	M4×16	5.1	8.94	0.06	0.03	0.03	0.12	1.26			
EW15CC							26	39.8	57.8																											
EW20SC	28	6	19.5	59	49	5	-	29	50	4.2	4.2	12	M6	7	7	9	5.8	6.3	20	15.5	9.5	8.5	6	60	20	M5×16	6.54	10.75	0.1	0.50	0.50	0.16	2.09			
EW20CC							32	48.1	69.1																											
EW25SC	33	6.2	25	73	60	6.5	-	35.5	59.7	5	5	12	M8	7.5	10	10	7.4	7.4	23	18	11	9	7	60	20	M6×20	10.2	17.6	0.2	0.09	0.09	0.26	2.69			
EW25CC							35	59	85																											
EW30SC	42	10	31	90	72	9	-	41.5	71.5	6	6	12	M10	7	10	10	9	9	28	23	11	9	7	80	20	M6×25	15.32	26.28	0.3	0.15	0.15	0.46	4.26			
EW30CC							40	70	100																											
EW30SC	42	10	31	90	72	9	-	41.5	71.5	6	6	12	M10	7	10	10	9	9	28	23	14	12	9	80	20	M8×25	15.32	26.28	0.3	0.15	0.15	0.46	4.26			
EW30CC							40	70	100																											
EW35SC	48	11	33	100	82	9	-	45	75	7	7	12	M10	10	13	13	8.5	8.5	34	27.5	14	12	9	80	20	M8×25	20.65	35.58	0.46	0.2	0.2	0.75	6.11			
EW35CC							50	78	108																											

Note : 1 kgf = 9.81 N
Model with "" means guide rail with new installation hole, pls not the requirement when placing the order.

(4) Dimensions for ER-U (large mounting hole, rail mounting from top)

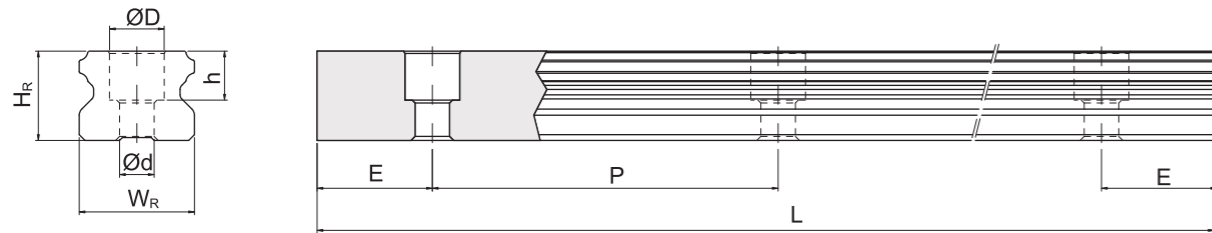

Model No.	Mounting Bolt for Rail(mm)	Dimensions of Rail (mm)							Weight (kg/m)
		W _R	H _R	D	h	d	P	E	
ER15U	M4x16	15	12.5	7.5	5.3	4.5	60	20	1.23
ER30U	M8x25	28	23	14	12	9	80	20	4.23

(5) Dimensions for ER-T (rail mounting from bottom)

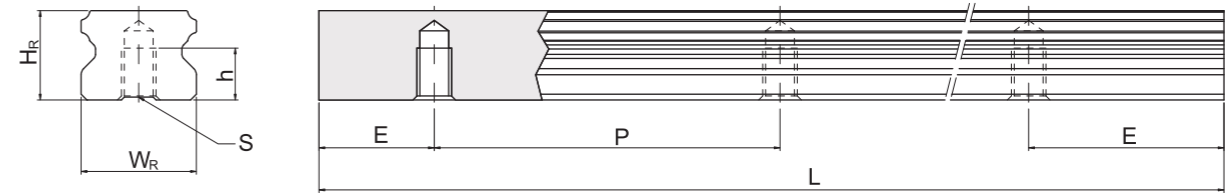

Model No.	Dimensions of Rail (mm)						Weight (kg/m)
	W _R	H _R	S	h	P	E	
ER15T	15	12.5	M5 x 0.8P	7	60	20	1.26
ER20T	20	15.5	M6 x 1P	9	60	20	2.15
ER25T	23	18	M6 x 1P	10	60	20	2.79
ER30T	28	23	M8 x 1.25P	14	80	20	4.42
ER35T	34	27.5	M8 x 1.25P	17	80	20	6.34

2-3 QH Series – Quiet Linear Guideway, with SynchMotion™ Technology

The development of LIMON-QH linear guideway is based on a four-row circular-arc contact. The LIMON-QH series linear guideway with SynchMotion™ Technology offers smooth movement, superior lubrication, quieter operation and longer running life. Therefore the LIMON-QH linear guideway has broad industrial applicability. In the high-tech industry where high speed, low noise, and reduced dust generation is required, the LIMON-QH series is interchangeable with the LIMON-H series.

2-3-1 Features of QH Series

(1) Low Noise Design

With SynchMotion™ technology, rolling elements are interposed between the partitions of SynchMotion™ to provide improved circulation. Due to the elimination of contact between the rolling elements, collision noise and sound levels are drastically reduced.

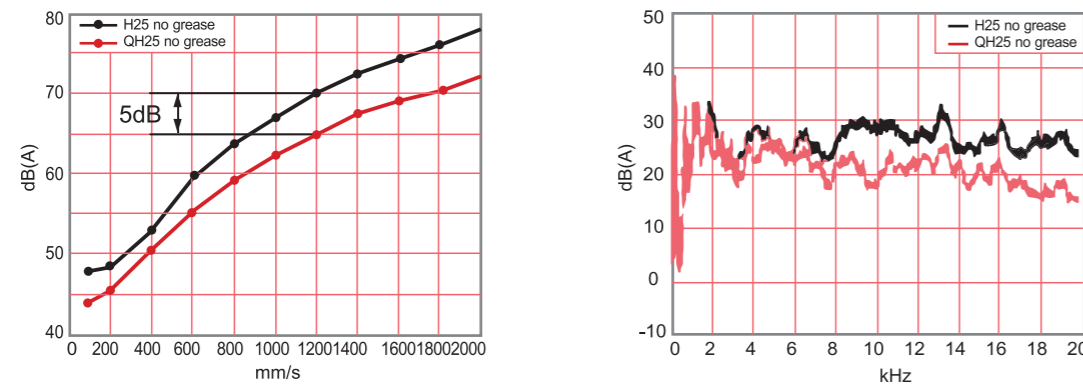

(2) Self-Lubricant Design

The partition is a grouping of hollow ring-like structures formed with a through hole to facilitate circulation of the lubricant. Because of the special lubrication path design, the lubricant of the partition storage space can be refilled. Therefore, the frequency of lubricant refilling can be decreased. The QH-series linear guideway is pre-lubricated. Performance testing at a 0.2C (basic dynamic load) shows that after running 4,000km no damage was apparent to either the rolling elements or the raceway.

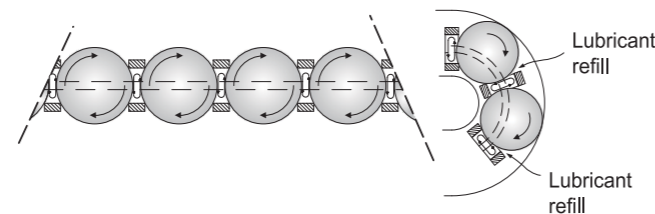

(3) Smooth Movement

In standard linear guideways, rolling elements on the load side of the guide block begin rolling and push their way through the raceway. When they contact other rolling elements they create counter-rotational friction. This results in a great variation of rolling resistance. The QH linear guideway, with SynchMotion™ technology prevents this condition. As the block starts to move, the rolling elements begin rolling consecutively and remain separated to prevent contact with one another thus keeping the element's kinetic energy extremely stable in order to effectively reduce fluctuations in rolling resistance.

(4) High Speed Performance

The LIMON-QH series offers excellent high-speed performance due to the partitions of the SynchMotion™ structure. They are employed to separate the adjacent balls thereby resulting in low rolling traction and the metallic friction between adjacent balls is eliminated.

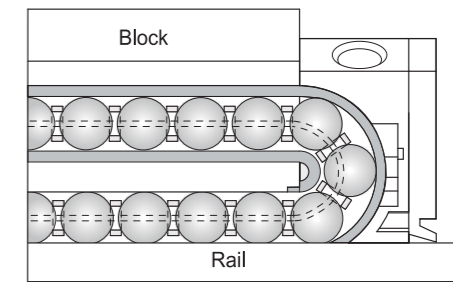

2-3-2 Construction of QH Series

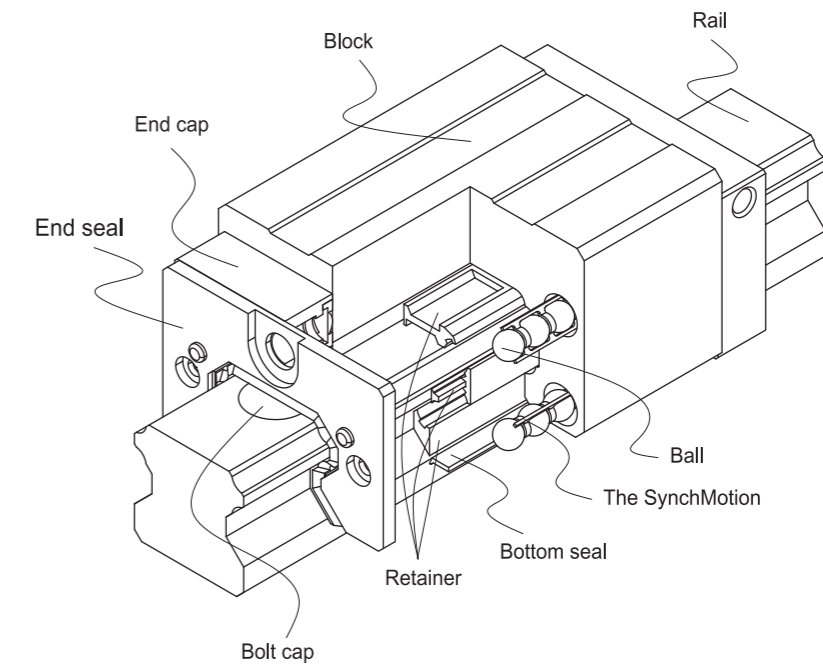

2-3-3 Model Number of QH Series

LIMON-QH series guideway can be classified into non-interchangeable and interchangeable types. The sizes are identical. The main difference is that the interchangeable blocks and rails can be freely exchanged. Because of dimensional control, the interchangeable type linear guideway is a perfect choice for the client when rails do not need to be paired for an axis. And since the QH and H share the identical rails, the customer does not need to redesign when choosing the QH series. Therefore the LIMON-QH linear guideway has increased applicability.

(1) Non-interchangeable type

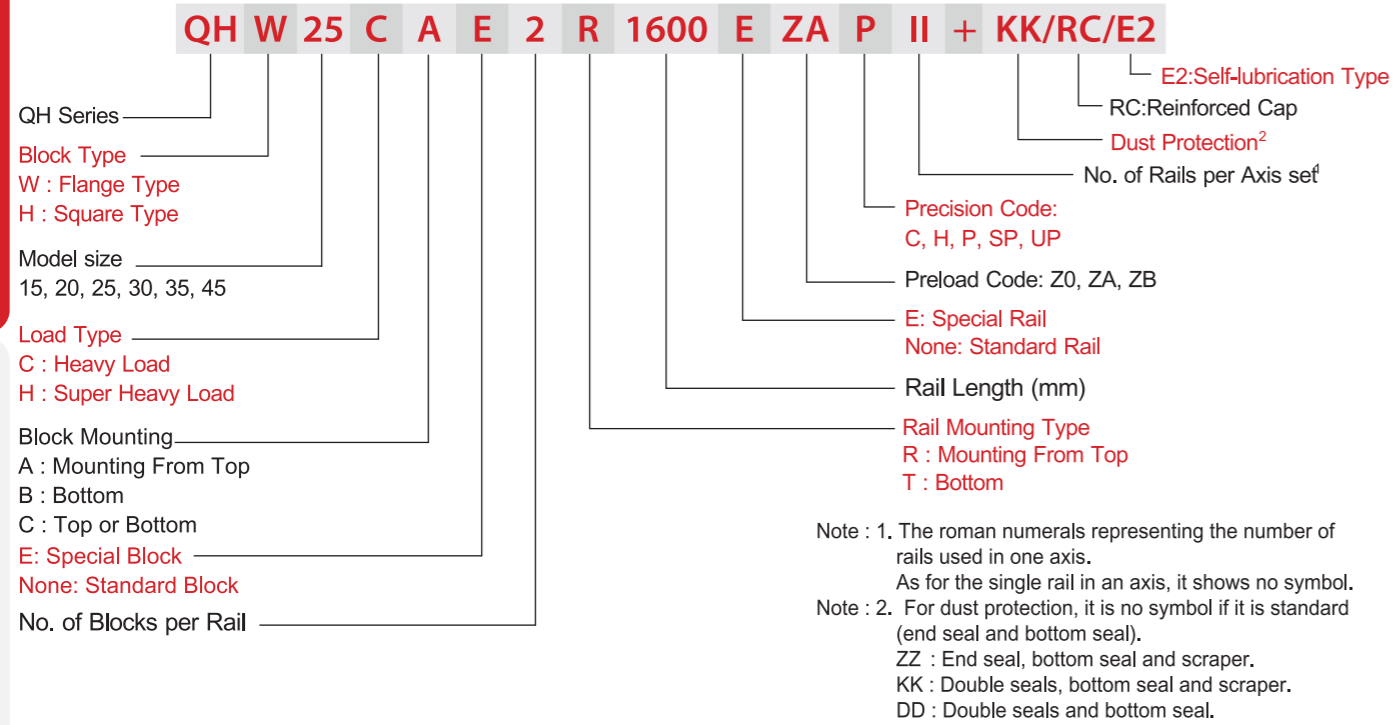

(2) Interchangeable type

□ Model Number of QH Block

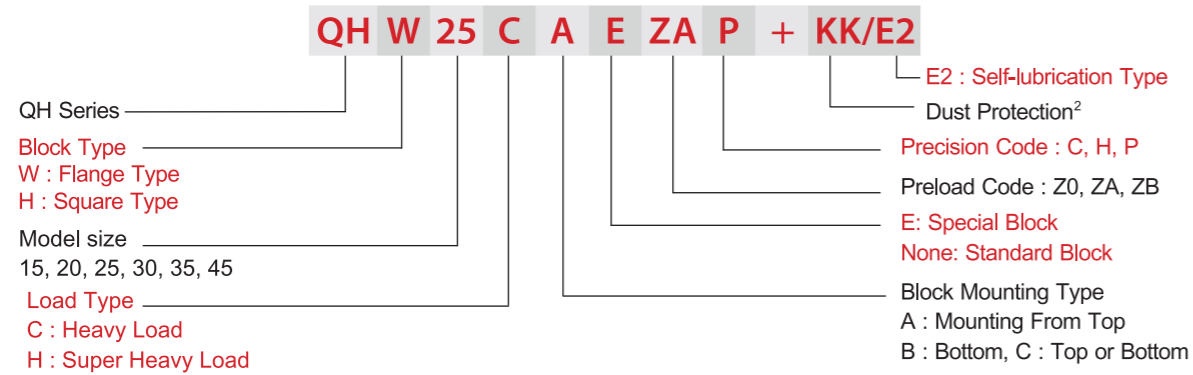

□ Model Number of QH Rail (QH and H share the identical rails)

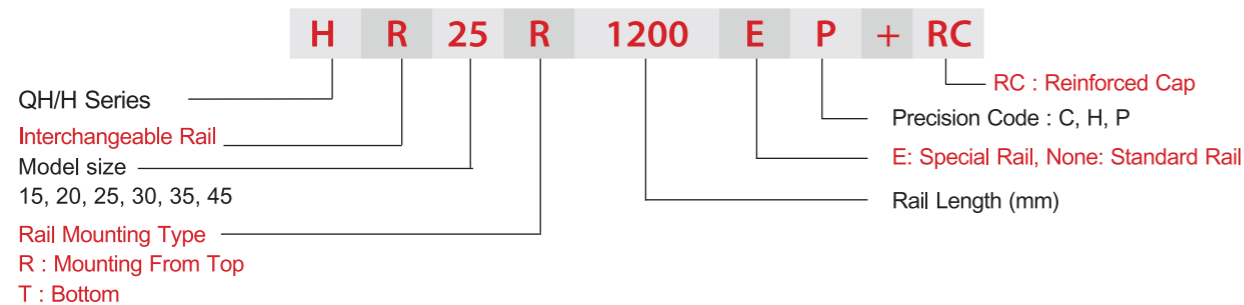

2-3-4 Types

(1) Block types

LIMON offers two types of linear guideways, flange and square types.

Table 2-3-1 Block Types

Type	Model	Shape	Height (mm)	Rail Length (mm)	Main Applications
Square	QHH-CA QHH-HA		28	100	<input type="checkbox"/> Automation devices <input type="checkbox"/> High-speed transportation equipment <input type="checkbox"/> Precision measuring equipment <input type="checkbox"/> Semiconductor manufacturing equipment
			70	4000	
Flange	QHW-CA QHW-HA		24	100	
			60	4000	
			24	100	
			60	4000	
Flange	QHW-CB QHW-HB		24	100	
			60	4000	
Flange	QHW-CC QHW-HC		24	100	
			60	4000	

(2) Rail types

Besides the standard top mounting type, the bottom mounting type is also available.

Table 2-3-2 Rail Types



2-3-5 Accuracy

The accuracy of QH series can be classified into normal (C), high (H), precision (P), super precision (SP), ultra precision (UP), five classes. Please choose the class by referring the accuracy of applied equipment.

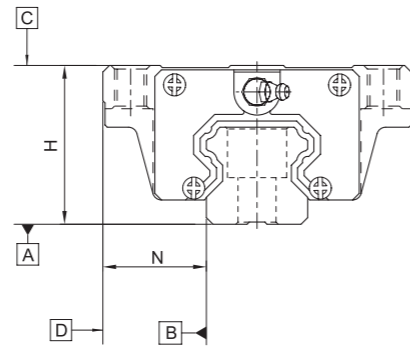

(1) Accuracy of non-interchangeable

Table 2-3-3 Accuracy Standards

Unit: mm

Item	QH - 15, 20				
	Normal (C)	High (H)	Precision (P)	Super Precision (SP)	Ultra Precision (UP)
Dimensional tolerance of height H	± 0.1	± 0.03	0 -0.03	0 -0.015	0 -0.008
Dimensional tolerance of width N	± 0.1	± 0.03	0 -0.03	0 -0.015	0 -0.008
Variation of height H	0.02	0.01	0.006	0.004	0.003
Variation of width N	0.02	0.01	0.006	0.004	0.003
Running parallelism of block surface C to surface A	See Table 2-3-9				
Running parallelism of block surface D to surface B	See Table 2-3-9				

Table 2-3-4 Accuracy Standards

Unit: mm

Item	QH - 25, 30, 35				
	Normal (C)	High (H)	Precision (P)	Super Precision (SP)	Ultra Precision (UP)
Dimensional tolerance of height H	± 0.1	± 0.04	0 -0.04	0 -0.02	0 -0.01
Dimensional tolerance of width N	± 0.1	± 0.04	0 -0.04	0 -0.02	0 -0.01
Variation of height H	0.02	0.015	0.007	0.005	0.003
Variation of width N	0.03	0.015	0.007	0.005	0.003
Running parallelism of block surface C to surface A	See Table 2-3-9				
Running parallelism of block surface D to surface B	See Table 2-3-9				

Table 2-3-5 Accuracy Standards

Unit: mm

Item	QH - 45				
	Normal (C)	High (H)	Precision (P)	Super Precision (SP)	Ultra Precision (UP)
Dimensional tolerance of height H	± 0.1	± 0.05	0 -0.05	0 -0.03	0 -0.02
Dimensional tolerance of width N	± 0.1	± 0.05	0 -0.05	0 -0.03	0 -0.02
Variation of height H	0.03	0.015	0.007	0.005	0.003
Variation of width N	0.03	0.02	0.01	0.007	0.005
Running parallelism of block surface C to surface A	See Table 2-3-9				
Running parallelism of block surface D to surface B	See Table 2-3-9				

(2) Accuracy of interchangeable

Table 2-3-6 Accuracy Standards

Unit: mm

Item	QH - 15, 20		
	Normal (C)	High (H)	Precision (P)
Dimensional tolerance of height H	± 0.1	± 0.03	± 0.015
Dimensional tolerance of width N	± 0.1	± 0.03	± 0.015
Variation of height H	0.02	0.01	0.006
Variation of width N	0.02	0.01	0.006
Running parallelism of block surface C to surface A	See Table 2-3-9		
Running parallelism of block surface D to surface B	See Table 2-3-9		

Table 2-3-7 Accuracy Standards

Unit: mm

Item	QH - 25, 30, 35		
	Normal (C)	High (H)	Precision (P)
Dimensional tolerance of height H	± 0.1	± 0.04	± 0.02
Dimensional tolerance of width N	± 0.1	± 0.04	± 0.02
Variation of height H	0.02	0.015	0.007
Variation of width N	0.03	0.015	0.007
Running parallelism of block surface C to surface A	See Table 2-3-9		
Running parallelism of block surface D to surface B	See Table 2-3-9		

Table 2-3-8 Accuracy Standards

Unit: mm

Item	QH - 45		
	Normal (C)	High (H)	Precision (P)
Dimensional tolerance of height H	± 0.1	± 0.05	± 0.025
Dimensional tolerance of width N	± 0.1	± 0.05	± 0.025
Variation of height H	0.03	0.015	0.007
Variation of width N	0.03	0.02	0.01
Running parallelism of block surface C to surface A	See Table 2-3-9		
Running parallelism of block surface D to surface B	See Table 2-3-9		

(3) Accuracy of running parallelism

Table 2-3-9 Accuracy of Running Parallelism

Rail Length (mm)	Accuracy (μm)				
	C	H	P	SP	UP
~ 100	12	7	3	2	2
100 ~ 200	14	9	4	2	2
200 ~ 300	15	10	5	3	2
300 ~ 500	17	12	6	3	2
500 ~ 700	20	13	7	4	2
700 ~ 900	22	15	8	5	3
900 ~ 1,100	24	16	9	6	3
1,100 ~ 1,500	26	18	11	7	4
1,500 ~ 1,900	28	20	13	8	4
1,900 ~ 2,500	31	22	15	10	5
2,500 ~ 3,100	33	25	18	11	6
3,100 ~ 3,600	36	27	20	14	7
3,600 ~ 4,000	37	28	21	15	7

2-3-6 Preload

(1) Definition

A preload can be applied to each guideway. Oversized balls are used. Generally, a linear motion guideway has a negative clearance between groove and balls in order to improve stiffness and maintain high precision. The figure shows the load is multiplied by the preload, the rigidity is doubled and the deflection is reduced by one half. The preload no larger than ZA would be recommended for the model size under QH20 to avoid an over-preload affecting the guideway's life.

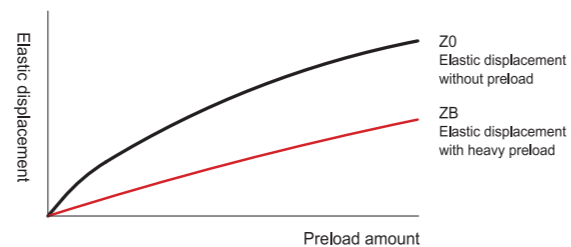

(2) Preload classes

LIMON offers three classes of standard preload for various applications and conditions.

Table 2-3-10 Preload Classes

Class	Code	Preload	Condition	Examples of Application
Light Preload	Z0	0~ 0.02C	Certain load direction, low impact, low precision required	Transportation devices, auto-packing machines, X-Y axis for general industrial machines, welding machines, welders
Medium Preload	ZA	0.05C~0.07C	High precision required	Machining centers, Z axis for general industrial machines, EDM, NC lathes, Precision X-Y tables, measuring equipment
Heavy Preload	ZB	0.10C~ 0.12C	High rigidity required, with vibration and impact	Machining centers, grinding machines, NC lathes, horizontal and vertical milling machines, Z axis of machine tools, Heavy cutting machines
Class	Interchangeable Guideway		Non-Interchangeable Guideway	
Preload classes	Z0, ZA		Z0, ZA, ZB	

Note: The "C" in the preload column denotes basic dynamic load rating.

2-3-7 Dust Proof Accessories

(1) Codes of accessories

If the following accessories are needed, please add the code followed by the model number.

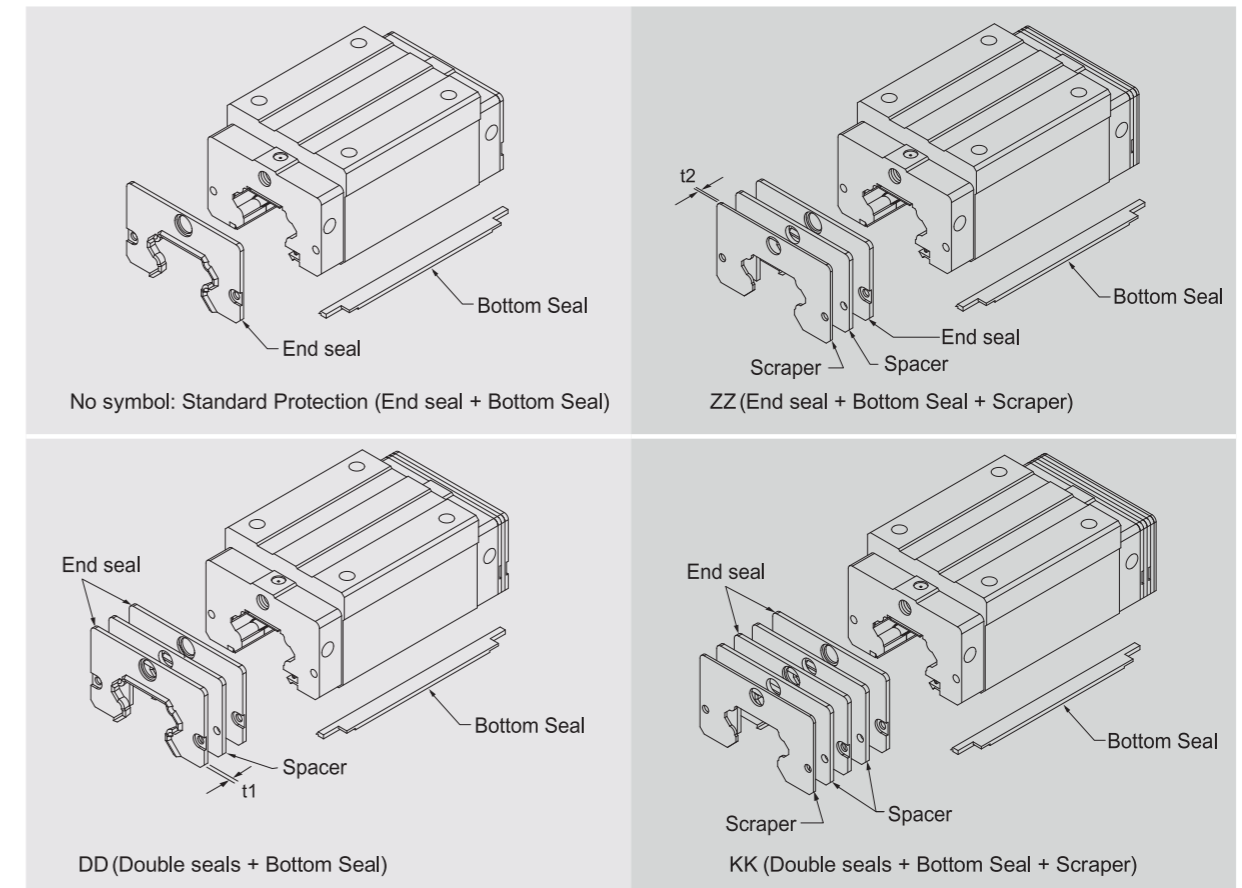

(2) End seal and bottom seal

To prevent life reduction caused by iron chips or dust entering the block.

(3) Double seals

Enhances the wiping effect, foreign matter can be completely wiped off.

Table 2-3-11 Dimensions of end seal

Size	Thickness (t1) (mm)	Size	Thickness (t1) (mm)
QH15 ES	3	QH30 ES	3.2
QH20 ES	2.5	QH35 ES	2.5
QH25 ES	2.5	QH45 ES	3.6

(4) Scraper

The scraper removes high-temperature iron chips and larger foreign objects.

Table 2-3-12 Dimensions of scraper

Size	Thickness (t2) (mm)	Size	Thickness (t2) (mm)
QH15 SC	1.5	QH30 SC	1.5
QH20 SC	1.5	QH35 SC	1.5
QH25 SC	1.5	QH45 SC	1.5

(5) Dimensions of block equipped with the dustproof parts

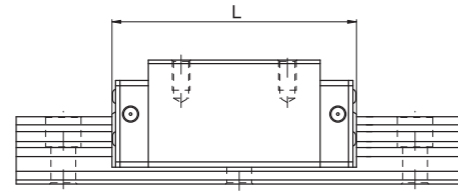

Table 2-3-13 Overall block length

unit: mm

Size	Overall block length (L)			
	SS	ZZ	DD	KK
QH15C	60.5	64.1	65.5	69.1
QH20C	76.7	80.3	82.5	86.1
QH20H	91.4	95	97.2	100.8
QH25C	84	87.6	90	93.6
QH25H	104.6	108.2	110.6	114.2
QH30C	98.4	102	104.6	108.2
QH30H	121.4	125	127.6	131.2
QH35C	112.4	116	118.8	122.4
QH35H	138.2	141.8	144.6	148.2
QH45C	137.4	141	145.4	149
QH45H	169.2	172.8	177.2	180.8

Note : The marking of "()" denotes the maximum block length with screws, lips of end seals, etc.

2-3-8 Dimensions for QH Series

(1) QHH-CA / QHH-HA

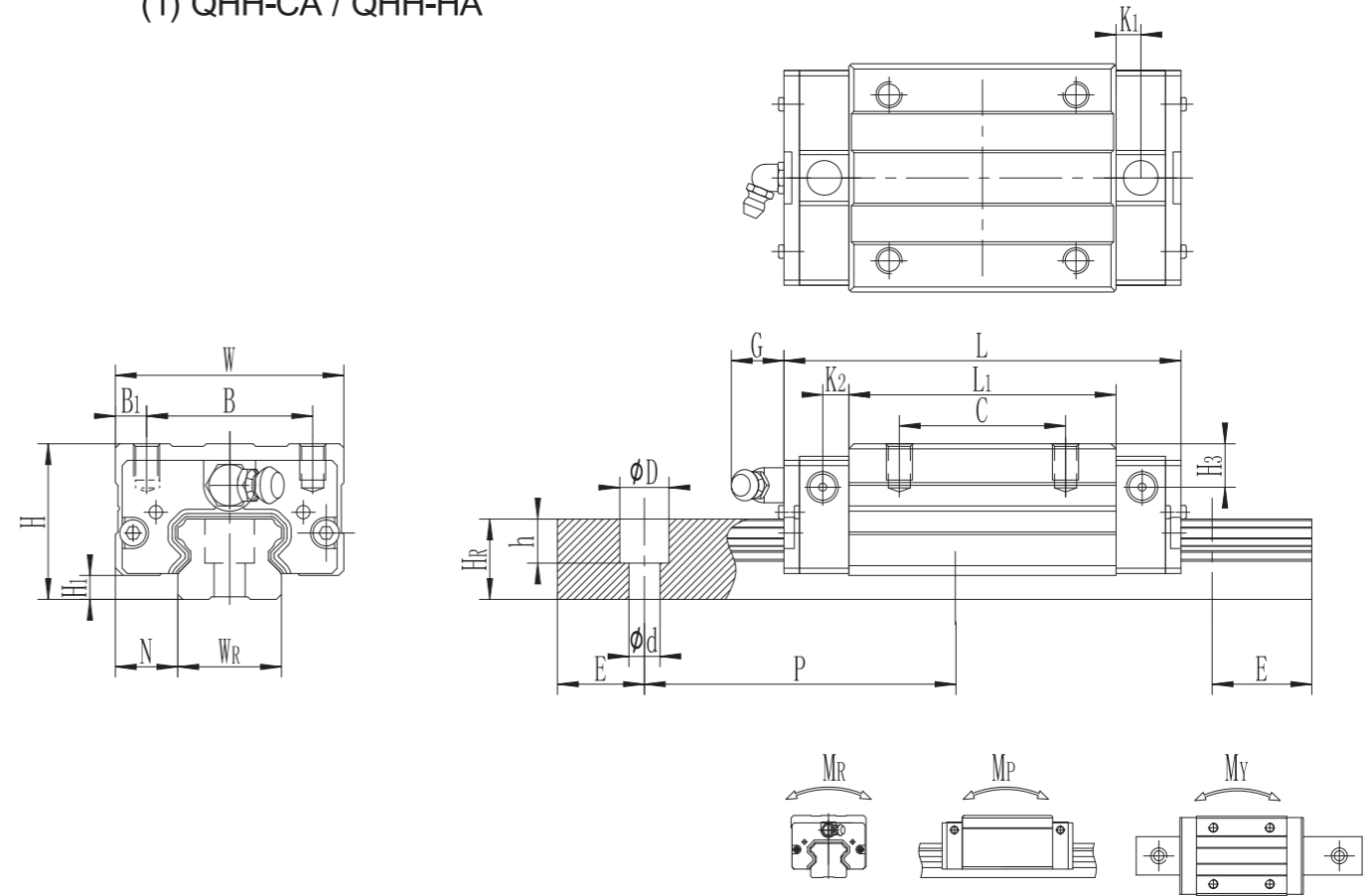

Model No.	Dimensions of Assembly (mm)		Dimensions of Block(mm)														Dimensions of Rail (mm)		Mounting Bolt for Rail (mm)	Basic Dynamic Load Rating C(KN)	Basic Static Load Rating C0(KN)	Static Rated Moment			Weight						
	H	H1	N	W	B	B1	C	L1	L	K1	K2	G	M*L	T	H2	H3	WR	HR				D	h	d	P	E	MR	MP	MY	Block kg	Rail kg/m
★ QHH15CA	28	3.2	9.5	34	26	4	26	39.8	62.2	3.5	3.5	5.5	M4X7	6	9.5	9	15	12.5	6	4.5	3.5	60	20	M3×16	11.96	14.46	0.08	0.06	0.06	0.21	1.26
QH15CA	28	3.2	9.5	34	26	4	26	39.8	62.2	3.5	3.5	5.5	M4X7	6	9.5	9	15	12.5	7.5	5.3	4.5	60	20	M4×16	11.96	14.46	0.08	0.06	0.06	0.21	1.26
QH20CA	30	4.6	12	44	32	6	36	51.5	76.5	4.75	5	12	M5X7	8	8	8.5	20	15.5	9.5	8.5	6	60	20	M5×16	17.46	21.59	0.22	0.15	0.15	0.32	2.09
QH20HA	30	4.6	12	44	32	6	50	69.5	94.5	4.75	5	12	M5X7	8	8	8.5	20	15.5	9.5	8.5	6	60	20	M5×16	21.14	28.33	0.28	0.25	0.25	0.4	2.09
QH25CA	40	4.5	12.5	48	35	6.5	35	59.5	82.5	4.75	5	12	M6X8	8	13	13	23	18	11	9	7	60	20	M6×20	25.65	29.52	0.35	0.25	0.25	0.55	2.69
QH25HA	40	4.5	12.5	48	35	6.5	50	81.5	104.5	4.75	5	12	M6X8	8	13	13	23	18	11	9	7	60	20	M6×20	32.88	42.17	0.48	0.42	0.42	0.72	2.69
QH30CA	45	7	16	60	40	10	40	70	98	6	5	12	M8X10	8.5	11	11	28	23	11	9	7	80	20	M6×25	42.17	45.22	0.52	0.45	0.45	0.9	4.26
QH30HA	45	7	16	60	40	10	60	93.5	121.5	6	5	12	M8X10	8.5	11	11	28	23	11	9	7	80	20	M6×25	52.09	62.13	0.8	0.85	0.85	1.18	4.26
QH35CA	45	7	16	60	40	10	40	70	98	6	5	12	M8X10	8.5	11	11	28	23	14	12	9	80	20	M8×25	42.17	45.22	0.52	0.45	0.45	0.9	4.26
QH35HA	45	7	16	60	40	10	60	93.5	121.5	6	5	12	M8X10	8.5	11	11	28	23	14	12	9	80	20	M8×25	52.09	62.13	0.8	0.85	0.85	1.18	4.26

Note : 1 kgf = 9.81 N

Model with "*" means guide rail with new installation hole, pls not the requirement when placing the order.

(2) QHW-CA / QHW-HA

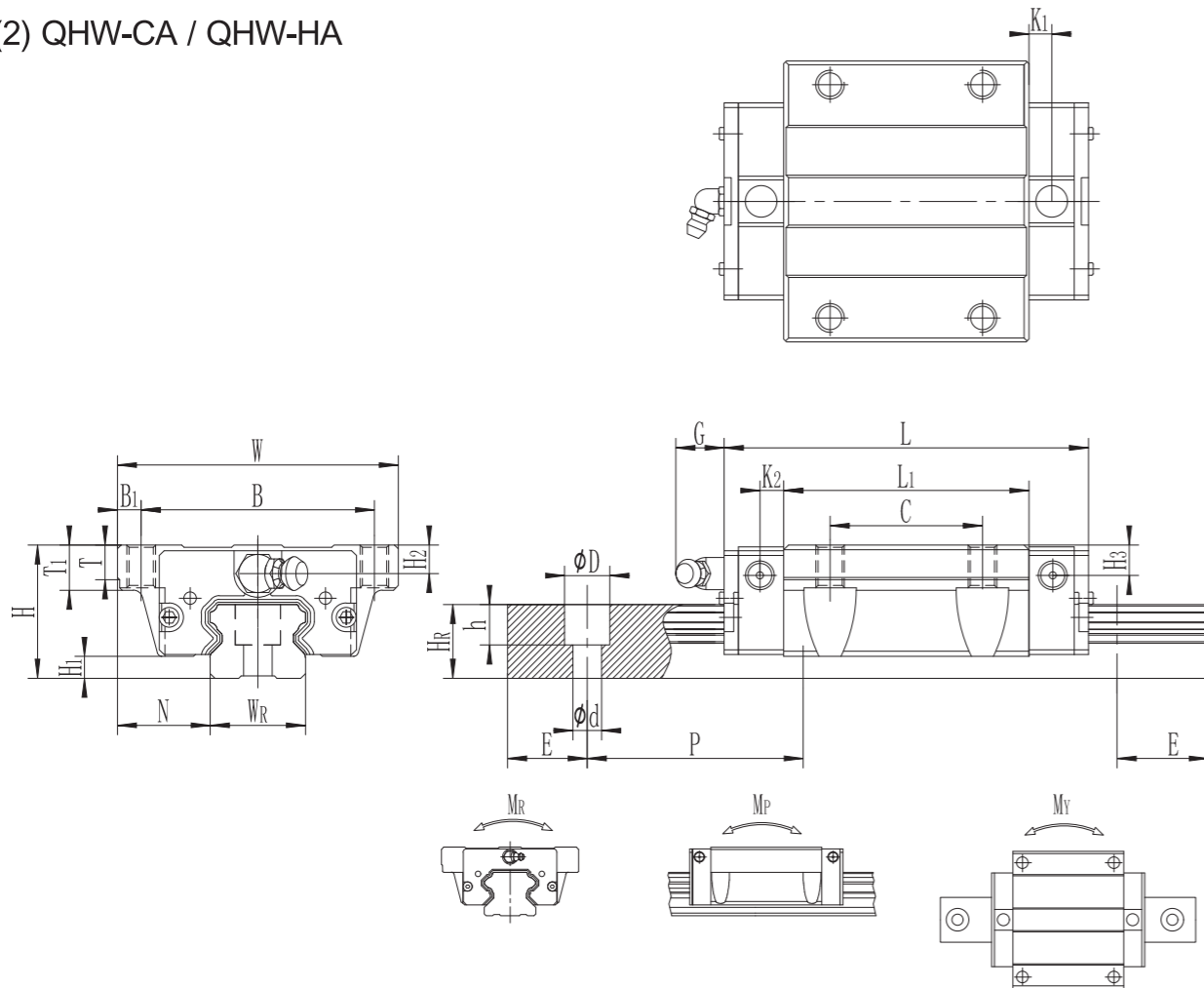

(3) QHW-CB / QHW-HB

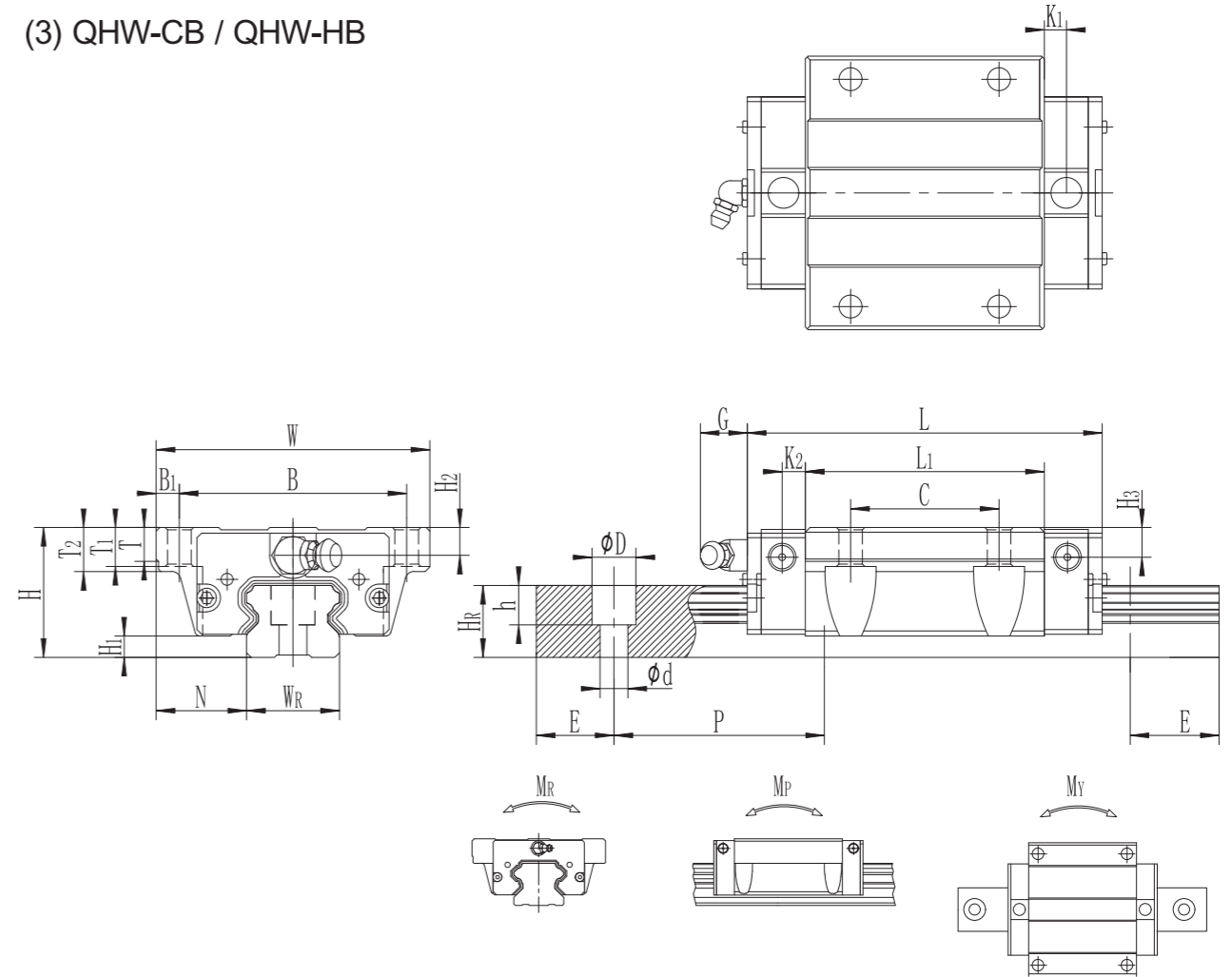

Model No.	Dimensions of Assembly (mm)		Dimensions of Block(mm)														Mounting Bolt for Rail (mm)	Basic Dynamic Load Rating C(KN)	Basic Static Load Rating C0(KN)	Static Rated Moment			Weight									
	H	H1	N	W	B	B1	C	L1	L	K1	K2	G	M	T	T1	T2				H2	H3	WR	Hr	D	h	d	P	E	MR	MP	MY	Block kg
★ QHW15CA	24	4	16	47	38	4.5	30	39.8	62.2	3.35	4.75	5.5	M5	6	7	5.5	5	15	12.5	6	4.5	3.5	60	20	M3×16	11.96	14.46	0.08	0.06	0.06	0.21	1.26
QHW15CA	24	4	16	47	38	4.5	30	39.8	62.2	3.35	4.75	5.5	M5	6	7	5.5	5	15	12.5	7.5	5.3	4.5	60	20	M4×16	11.96	14.46	0.08	0.06	0.06	0.21	1.26
QHW20CA	30	4.6	21.5	63	53	5	40	51.5	76.5	4.75	5	12	M6	8	9	8	8.5	20	15.5	9.5	8.5	6	60	20	M5×16	17.46	21.59	0.22	0.15	0.15	0.32	2.09
QHW20HA								69.5	94.5																	21.14	28.33	0.28	0.25	0.25	0.4	
QHW25CA	36	4.5	23.5	70	57	6.5	45	59.5	82.5	4.75	5	12	M8	8	10	9	9	23	18	11	9	7	60	20	M6×20	25.65	29.52	0.35	0.25	0.25	0.55	2.69
QHW25HA								81.5	104.5																	32.88	42.17	0.48	0.42	0.42	0.72	
★ QHW30CA	42	7	31	90	72	9	52	70	98	6	5	12	M10	8	10	8	8	28	23	11	9	7	80	20	M6×25	42.17	45.22	0.52	0.45	0.45	0.9	4.26
QHW30HA								93.5	121.5																	52.09	62.13	0.8	0.85	0.85	1.18	
QHW30CA	42	7	31	90	72	9	52	70	98	6	5	12	M10	8	10	8	8	28	23	14	12	9	80	20	M8×25	42.17	45.22	0.52	0.45	0.45	0.9	4.26
QHW30HA								93.5	121.5																	52.09	62.13	0.8	0.85	0.85	1.18	

Note : 1 kgf = 9.81 N

Model with "*" means guide rail with new installation hole, pls not the requirement when placing the order.

Model No.	Dimensions of Assembly (mm)		Dimensions of Block(mm)														Mounting Bolt for Rail (mm)	Basic Dynamic Load Rating C(KN)	Basic Static Load Rating C0(KN)	Static Rated Moment			Weight										
	H	H1	N	W	B	B1	C	L1	L	K1	K2	G	M	T	T1	T2				H2	H3	WR	Hr	D	h	d	P	E	MR	MP	MY	Block kg	Rail kg/m
★ QHW15CB	24	4	16	47	38	4.5	30	39.8	62.2	3.35	4.75	5.5	φ4.5	6	7	8.9	5.5	5	15	12.5	6	4.5	3.5	60	20	M3×16	11.96	14.46	0.08	0.06	0.06	0.21	1.26
QHW15CB	24	4	16	47	38	4.5	30	39.8	62.2	3.35	4.75	5.5	φ4.5	6	7	8.9	5.5	5	15	12.5	7.5	5.3	4.5	60	20	M4×16	11.96	14.46	0.08	0.06	0.06	0.21	1.26
QHW20CB	30	4.6	21.5	63	53	5	40	51.5	76.5	4.75	5	12	φ6	8	9	10	8	8.5	20	15.5	9.5	8.5	6	60	20	M5×16	17.46	21.59	0.22	0.15	0.15	0.32	2.09
QHW20HB								69.5	94.5																		21.14	28.33	0.28	0.25	0.25	0.4	
QHW25CB	36	4.5	23.5	70	57	6.5	45	59.5	82.5	4.75	5	12	φ7	8	10	14	9	9	23	18	11	9	7	60	20	M6×20	25.65	29.52	0.35	0.25	0.25	0.55	2.69
QHW25HB								81.5	104.5																		32.88	42.17	0.48	0.42	0.42	0.72	
★ QHW30CB	42	7	31	90	72	9	52	70	98	6	5	12	φ9	8.5	10	16	8	8	28	23	11	9	7	80	20	M6×25	42.17	45.22	0.52	0.45	0.45	0.9	4.26
QHW30HB								93.5	121.5																		52.09	62.13	0.8	0.85	0.85	1.18	
QHW30CB	42	7	31	90	72	9	52	70	98	6	5	12	φ9	8.5	10	16	8	8	28	23	14	12	9	80	20	M8×25	42.17	45.22	0.52	0.45	0.45	0.9	4.26
QHW30HB								93.5	121.5																		52.09	62.13	0.8	0.85	0.85	1.18	

Note : 1 kgf = 9.81 N

Model with "*" means guide rail with new installation hole, pls not the requirement when placing the order.

(4) QHW-CC / QHW-HC

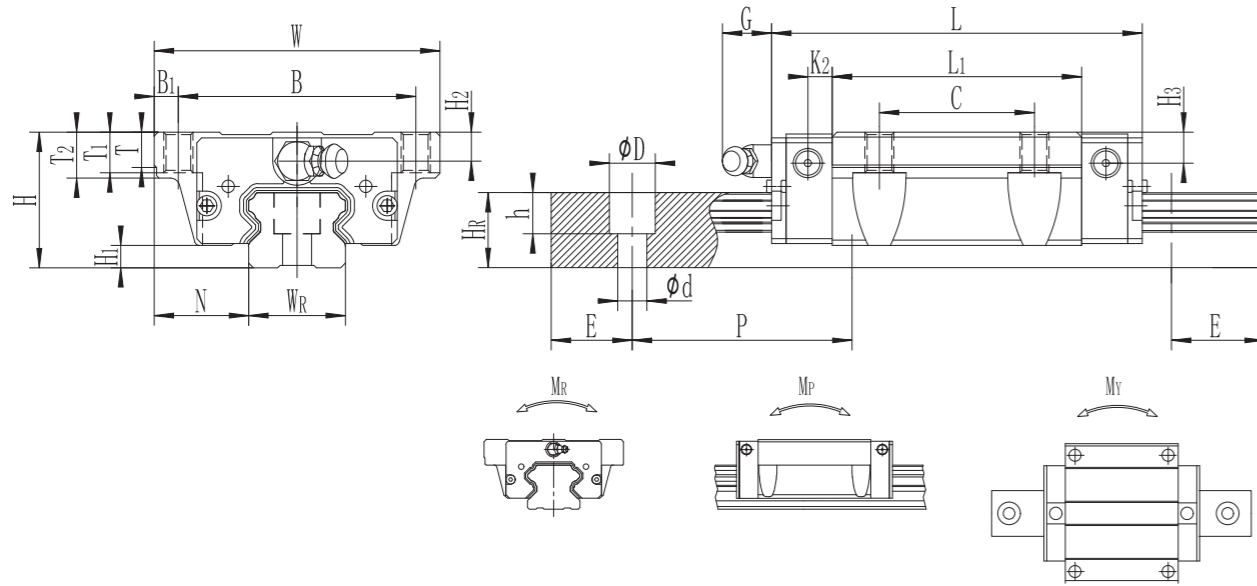
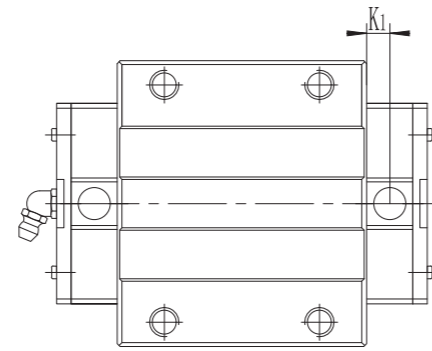

Model No.	Dimensions of Assembly (mm)			Dimensions of Block(mm)														Dimensions of Rail (mm)				Mounting Bolt for Rail (mm)	Basic Dynamic Load Rating C(KN)	Basic Static Load Rating C0(KN)	Static Rated Moment			Weight					
	H	H ₁	N	W	B	B ₁	C	L ₁	L	K ₁	K ₂	G	M	T	T ₁	T ₂	H ₂	H ₃	W _R	H _R	D				h	d	P	E	M _R KN-m	M _P KN-m	M _Y KN-m	Block kg	Rail kg/m
★ QHW15CC	24	4	16	47	38	4.5	30	39.8	62.2	3.35	4.75	5.5	M5	6	6.95	8.9	5.5	5	15	12.5	6	4.5	3.5	60	20	M3×16	11.96	14.46	0.08	0.06	0.06	0.21	1.26
QHW15CC	24	4	16	47	38	4.5	30	39.8	62.2	3.35	4.75	5.5	M5	6	6.95	8.9	5.5	5	15	12.5	7.5	5.3	4.5	60	20	M4×16	11.96	14.46	0.08	0.06	0.06	0.21	1.26
QHW20CC	30	4.6	21.5	63	53	5	40	51.5	76.5	4.75	5	12	M6	8	9	10	8	8.5	20	15.5	9.5	8.5	6	60	20	M5×16	17.46	21.59	0.22	0.15	0.15	0.32	2.09
QHW20HC	30	4.6	21.5	63	53	5	40	69.5	94.5	4.75	5	12	M6	8	9	10	8	8.5	20	15.5	9.5	8.5	6	60	20	M5×16	21.14	28.33	0.28	0.25	0.25	0.4	2.09
QHW25CC	36	4.5	23.5	70	57	6.5	45	59.5	82.5	4.75	5	12	M8	8	10	14	9	9	23	18	11	9	7	60	20	M6×20	25.65	29.52	0.35	0.25	0.25	0.55	2.69
QHW25HC	36	4.5	23.5	70	57	6.5	45	81.5	104.5	4.75	5	12	M8	8	10	14	9	9	23	18	11	9	7	60	20	M6×20	32.88	42.17	0.48	0.42	0.42	0.72	2.69
★ QHW30CC	42	7	31	90	72	9	52	70	98	6	5	12	M10	8.5	10	16	8	8	28	23	11	9	7	80	20	M6×25	42.17	45.22	0.52	0.45	0.45	0.9	4.26
QHW30HC	42	7	31	90	72	9	52	93.5	121.5	6	5	12	M10	8.5	10	16	8	8	28	23	11	9	7	80	20	M6×25	52.09	62.13	0.8	0.85	0.85	1.18	4.26
★ QHW30CC	42	7	31	90	72	9	52	70	98	6	5	12	M10	8.5	10	16	8	8	28	23	14	12	9	80	20	M8×25	42.17	45.22	0.52	0.45	0.45	0.9	4.26
QHW30HC	42	7	31	90	72	9	52	93.5	121.5	6	5	12	M10	8.5	10	16	8	8	28	23	14	12	9	80	20	M8×25	52.09	62.13	0.8	0.85	0.85	1.18	4.26

Note : 1 kgf = 9.81 N

Model with "*" means guide rail with new installation hole, pls not the requirement when placing the order.

2-4 QE Series – Low Profile Linear Guideway, with SynchMotion™ Technology

The development of LIMON-QE linear guideway is based on a four-row circular-arc contact. The LIMON-QE series linear guideway with SynchMotion™ Technology offers smooth movement, superior lubrication, quieter operation and longer running life. Therefore the LIMON-QE linear guideway has broad industrial applicability. In the high-tech industry where high speed, low noise, and reduced dust generation is required, the LIMON-QE series is interchangeable with the LIMON-E series.

2-4-1 Construction of QE Series

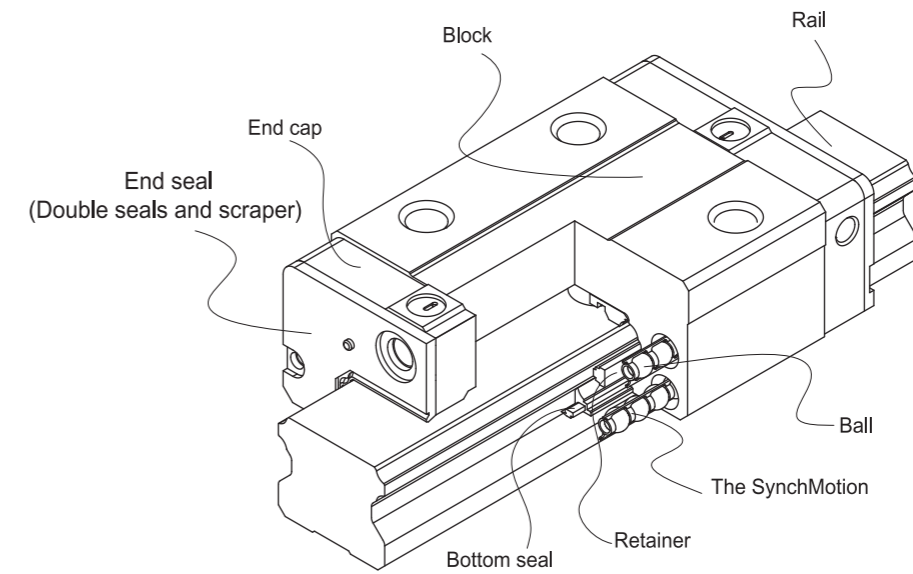

2-4-2 Model Number of QE Series

LIMON-QE series guideway can be classified into non-interchangeable and interchangeable types. The sizes are identical. The main difference is that the interchangeable blocks and rails can be freely exchanged. Because of dimensional control, the interchangeable type linear guideway is a perfect choice for the client when rails do not need to be paired for an axis. And since the QE and E share the identical rails, the customer does not need to redesign when choosing the QE series. Therefore the LIMON-QE linear guideway has increased applicability.

(1) Non-interchangeable type

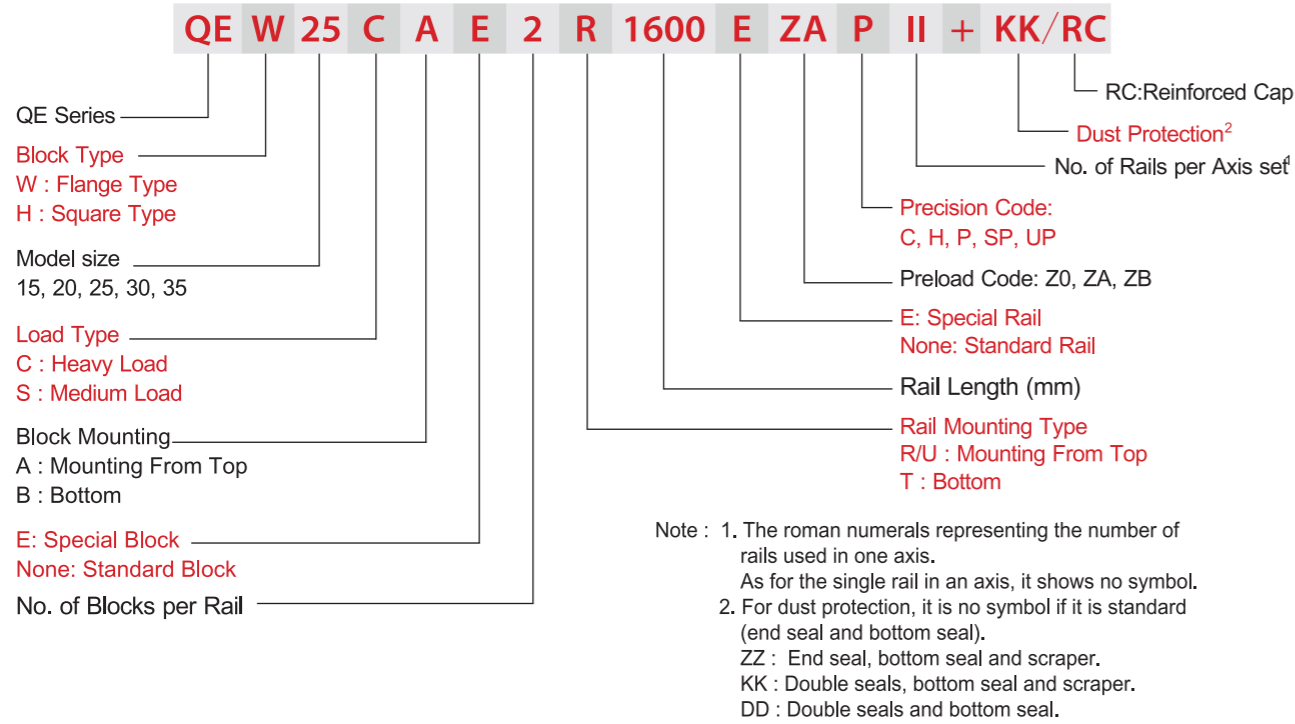

(2) Interchangeable type

□ Model Number of QE Block

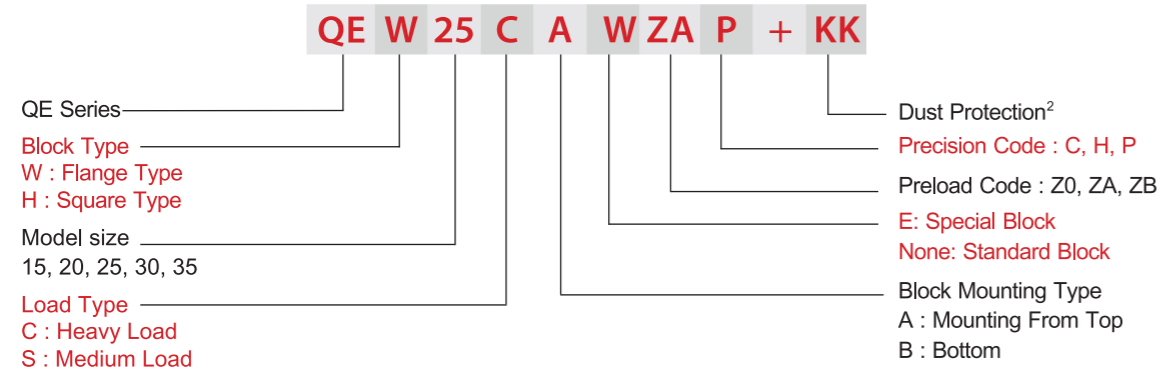

□ Model Number of QE Rail (QE and E share the identical rails)

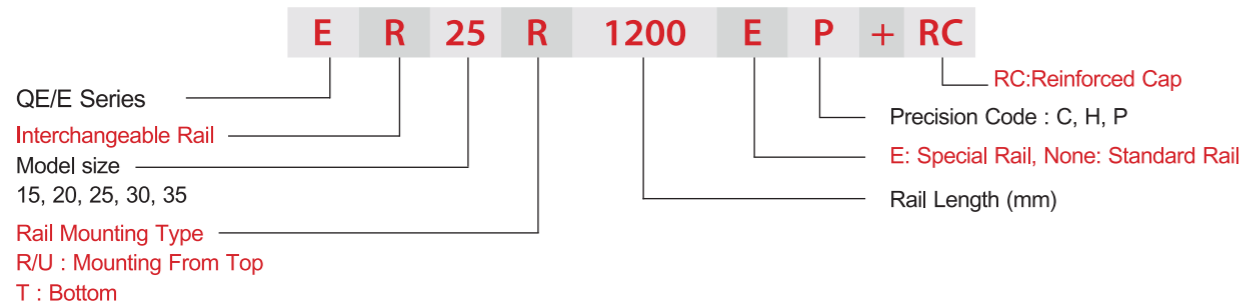

2-4-3 Types

(1) Block types

LIMON offers two types of linear guideways, flange and square types.

Table 2-4-1 Block Type

Type	Model	Shape	Height (mm)	Rail Length (mm)	Main Applications
Square	QEH-SA QEH-CA		24	100	<input type="checkbox"/> Automation devices <input type="checkbox"/> High-speed transportation equipment <input type="checkbox"/> Precision measuring equipment <input type="checkbox"/> Semiconductor manufacturing equipment
			↓	↓	
Flange	QEW-SA QEW-CA		48	4000	
			↓	↓	
			24	100	
			↓	↓	
	QEW-SB QEW-CB		48	4000	
			↓	↓	

(2) Rail types

Besides the standard top mounting type, the bottom mounting type is also available.

Table 2-4-2 Rail Types

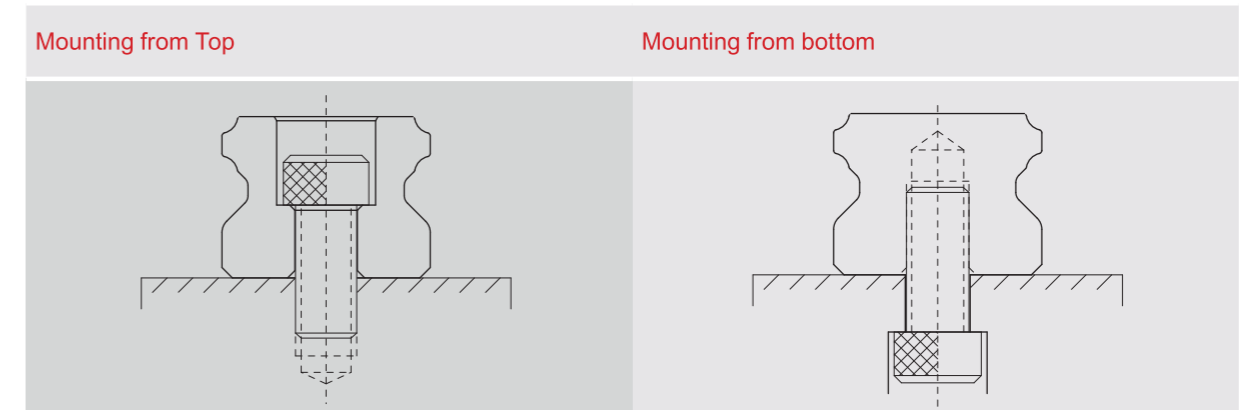

2-4-4 Accuracy

The accuracy of the QE series can be classified into 5 classes: normal(C), high(H), precision(P), super precision(SP), and ultra precision(UP). Choose the class by referencing the accuracy of selected equipment.

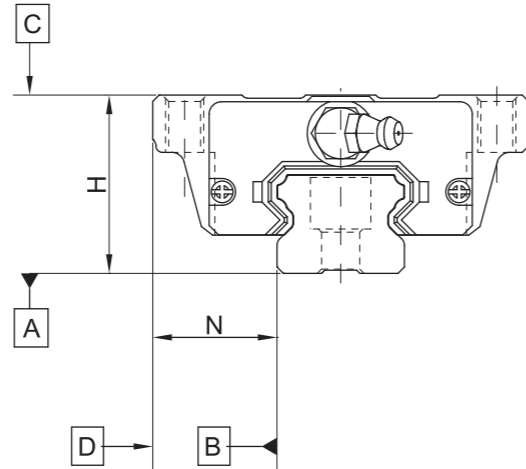

(1) Accuracy of non-interchangeable guideways

Table 2-4-3 Accuracy Standards

Item	QE - 15, 20				
	Normal (C)	High (H)	Precision (P)	Super Precision (SP)	Ultra Precision (UP)
Dimensional tolerance of height H	± 0.1	± 0.03	0 -0.03	0 -0.015	0 -0.008
Dimensional tolerance of width N	± 0.1	± 0.03	0 -0.03	0 -0.015	0 -0.008
Variation of height H	0.02	0.01	0.006	0.004	0.003
Variation of width N	0.02	0.01	0.006	0.004	0.003
Running parallelism of block surface C to surface A	See Table 2-4-7				
Running parallelism of block surface D to surface B	See Table 2-4-7				

Table 2-4-4 Accuracy Standards

Item	QE - 25, 30, 35				
	Normal (C)	High (H)	Precision (P)	Super Precision (SP)	Ultra Precision (UP)
Dimensional tolerance of height H	± 0.1	± 0.04	0 -0.04	0 -0.02	0 -0.01
Dimensional tolerance of width N	± 0.1	± 0.04	0 -0.04	0 -0.02	0 -0.01
Variation of height H	0.02	0.015	0.007	0.005	0.003
Variation of width N	0.03	0.015	0.007	0.005	0.003
Running parallelism of block surface C to surface A	See Table 2-4-7				
Running parallelism of block surface D to surface B	See Table 2-4-7				

(2) Accuracy of interchangeable guideways

Table 2-4-5 Accuracy Standards

Item	QE - 15, 20		
	Normal (C)	High (H)	Precision (P)
Dimensional tolerance of height H	± 0.1	± 0.03	± 0.015
Dimensional tolerance of width N	± 0.1	± 0.03	± 0.015
Variation of height H	0.02	0.01	0.006
Variation of width N	0.02	0.01	0.006
Running parallelism of block surface C to surface A	See Table 2-4-7		
Running parallelism of block surface D to surface B	See Table 2-4-7		

Table 2-4-6 Accuracy Standards

Item	QE - 25, 30, 35		
	Normal (C)	High (H)	Precision (P)
Dimensional tolerance of height H	± 0.1	± 0.04	± 0.02
Dimensional tolerance of width N	± 0.1	± 0.04	± 0.02
Variation of height H	0.02	0.015	0.007
Variation of width N	0.03	0.015	0.007
Running parallelism of block surface C to surface A	See Table 2-4-7		
Running parallelism of block surface D to surface B	See Table 2-4-7		

(3) Accuracy of running parallelism

Table 2-4-7 Accuracy of Running Parallelism

Rail Length (mm)	Accuracy (μm)				
	C	H	P	SP	UP
~ 100	12	7	3	2	2
100 ~ 200	14	9	4	2	2
200 ~ 300	15	10	5	3	2
300 ~ 500	17	12	6	3	2
500 ~ 700	20	13	7	4	2
700 ~ 900	22	15	8	5	3
900 ~ 1,100	24	16	9	6	3
1,100 ~ 1,500	26	18	11	7	4
1,500 ~ 1,900	28	20	13	8	4
1,900 ~ 2,500	31	22	15	10	5
2,500 ~ 3,100	33	25	18	11	6
3,100 ~ 3,600	36	27	20	14	7
3,600 ~ 4,000	37	28	21	15	7

2-4-5 Preload

(1) Definition

A preload can be applied to each guideway. Generally, a linear motion guideway has a negative clearance between the groove and balls in order to improve stiffness and maintain high precision. The figure shows that adding a preload can improve stiffness of the linear guideway. A preload no greater than ZA would be recommended for model sizes smaller than QE20. This will avoid an over-loaded condition that would affect guideway life.

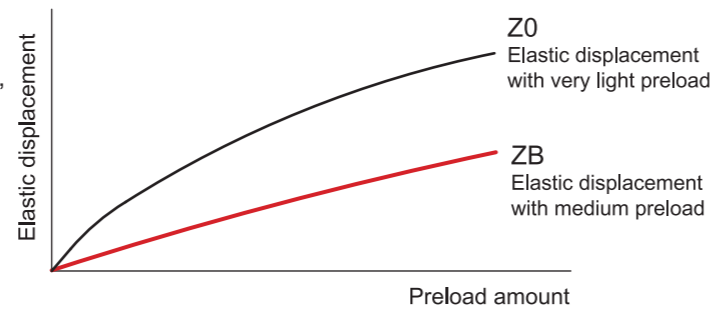

(2) Preload classes

LIMON offers three standard preloads for various applications and conditions.

Table 2-4-8 Preload Classes

Class	Code	Preload	Condition
Very Light Preload	Z0	0~ 0.02C	Certain load direction, low impact, low precision required
Light Preload	ZA	0.03C~0.05C	low load and high precision required
Medium Preload	ZB	0.06C~ 0.08C	High rigidity required, with vibration and impact

Class	Interchangeable Guideway	Non-Interchangeable Guideway
Preload classes	Z0, ZA	Z0, ZA, ZB

Note: The "C" in the preload column denotes basic dynamic load rating.

2-4-6 Dust Proof Accessories

(1) Codes of accessories

If the following accessories is needed, please indicate the code followed by the model number.

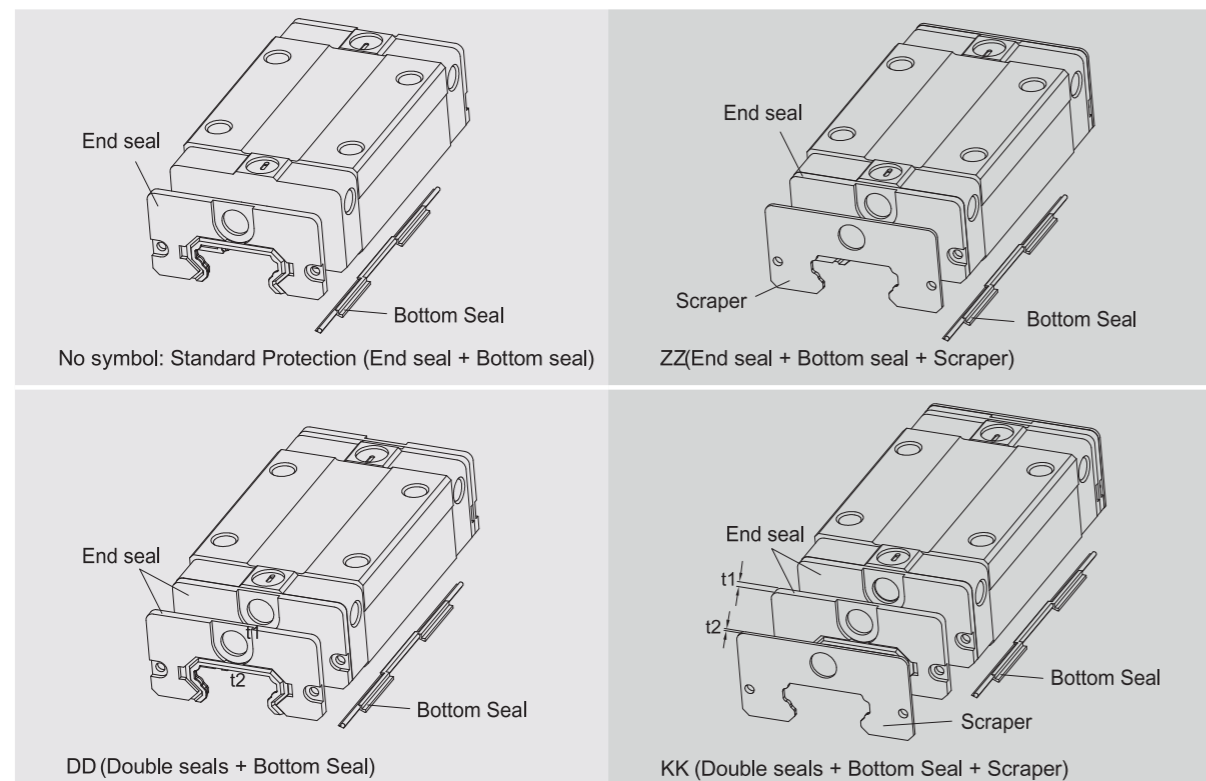

(2) End seal and bottom seal

To prevent life reduction caused by iron chips or dust entering the block

(3) Double seals

Removes foreign matter from the rail preventing contaminants from entering the block.

Table 2-4-9 Dimensions of end seal

Size	Thickness (t1) (mm)	Size	Thickness (t1) (mm)
QE15 ES	2	QE30 ES	2.5
QE20 ES	2	QE35 ES	2
QE25 ES	2.5		

(4) Scraper

Clears larger contaminants, such as weld spatter and metal cuttings, from the rail. Metal scraper protects end seals from excessive damage.

Table 2-4-10 Dimensions of Scraper

Size	Thickness (t2) (mm)
QE15 SC	1
QE20 SC	1
QE25 SC	1
QE30 SC	1
QE35 SC	1.5

(5) Dimensions of block equipped with the dustproof parts

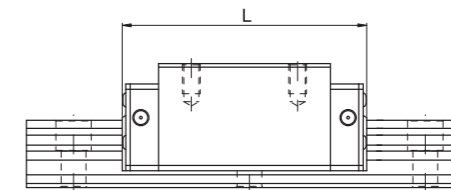

Table 2-4-11 Overall block length

unit: mm

Size	Overall block length (L)			
	SS	ZZ	DD	KK
QE15S	41.1	42.1	44.1	46.1
QE15C	56.8	57.8	60.8	62.8
QE20S	50	51.2	54	56
QE20C	69.1	71.1	73.1	75.1
QE25S	60.1	62.1	65.1	67.1
QE25C	83.6	85.6	88.6	90.6
QE30S	67.5	69.5	72.5	74.5
QE30C	96.1	98.1	101.1	103.1
QE35S	76	79	80	83
QE35C	108	111	112	115

Note : The marking of "()" denotes the maximum block length with screws, lips of end seals, etc.

2-4-7 Dimensions for QE Series

(1) QEH-CA / QEH-SA

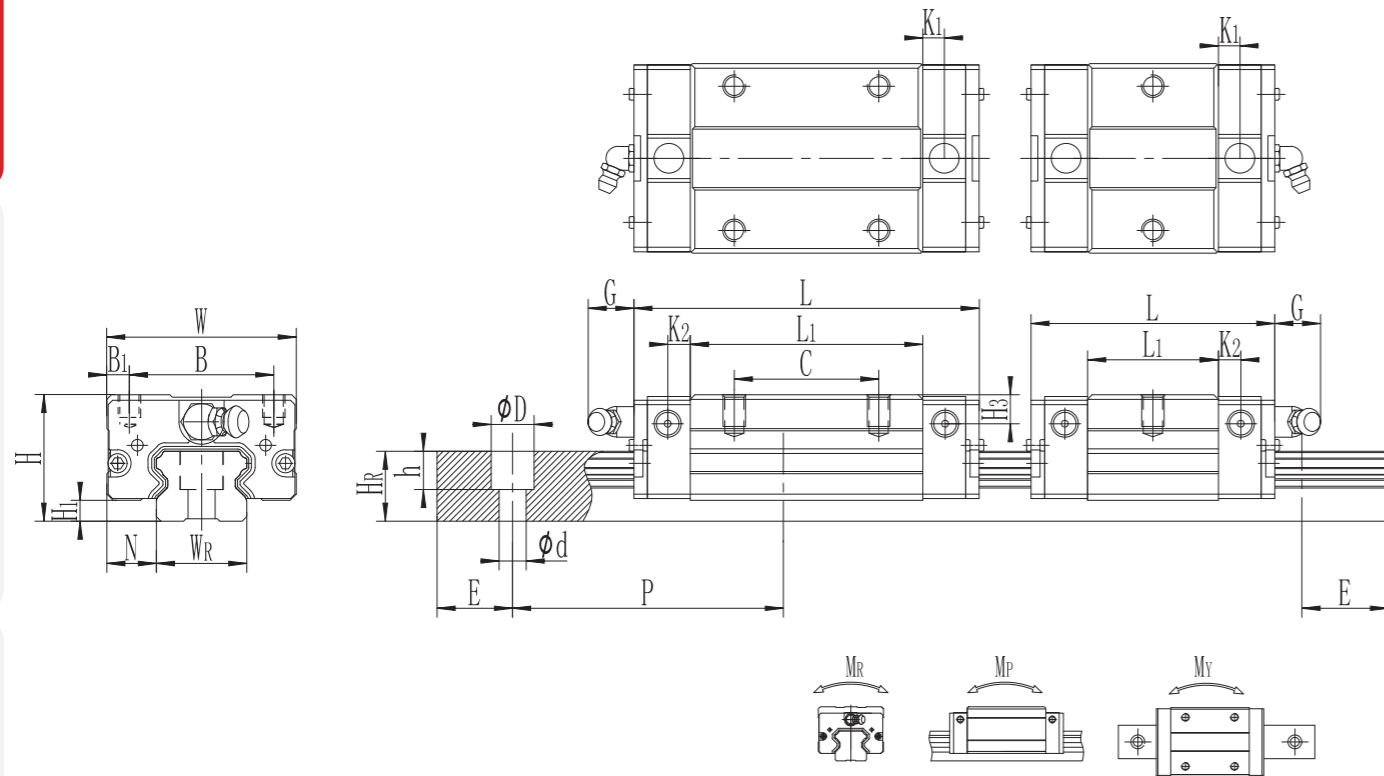

(2) QEW-CA / QEW-SA

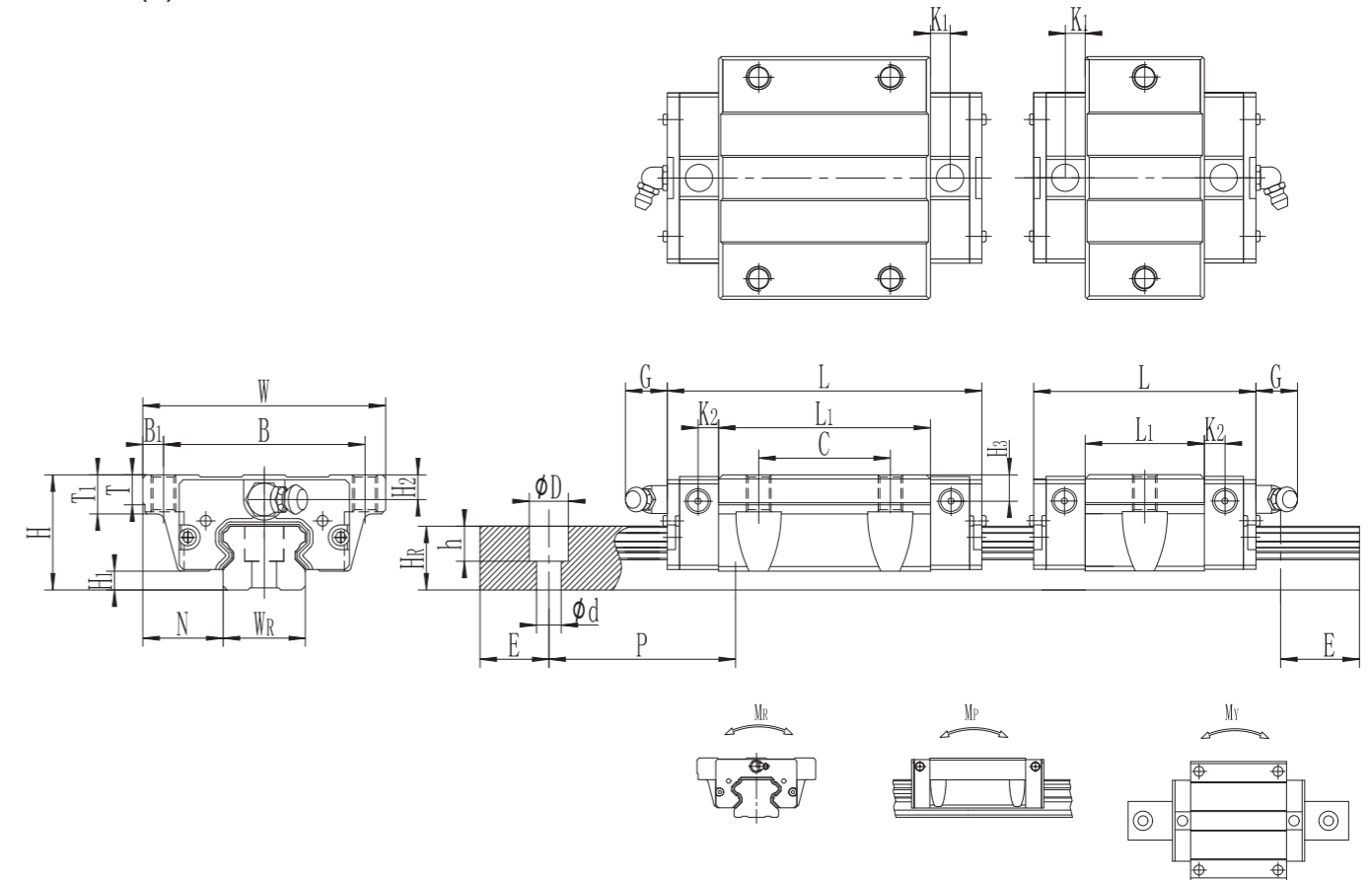

Linear Guideways

Ball Screw

Support

Linear Bushing

Linear Guideways

Ball Screw

Support

Linear Bushing

Model No.	Dimensions of Assembly (mm)		Dimensions of Block(mm)											Dimensions of Rail (mm)						Mounting Bolt for Rail (mm)	Basic Dynamic Load Rating C(KN)	Basic Static Load Rating C0(KN)	Static Rated Moment			Weight					
	H	H1	N	W	B	B1	C	L1	L	K1	K2	G	M*L	T	H2	H3	WR	HR	D				h	d	P	E	Mr	Mp	My	Block kg	Rail kg/m
QEH15SA	24	3.2	9.5	34	26	4	-	23.1	45.5	3.5	3.5	5.5	M4X5	5	5.5	5	15	12.5	6	4.5	3.5	60	20	M3x16	8.09	8.26	0.06	0.02	0.02	0.14	1.26
QEH15CA	24	3.2	9.5	34	26	4	-	23.1	45.5	3.5	3.5	5.5	M4X5	5	5.5	5	15	12.5	6	4.5	3.5	60	20	M3x16	11.96	14.46	0.11	0.08	0.08	0.25	1.26
QEH15SA	24	3.2	9.5	34	26	4	-	23.1	45.5	3.5	3.5	5.5	M4X5	5	5.5	5	15	12.5	7.5	5.3	4.5	60	20	M4x16	8.09	8.26	0.06	0.02	0.02	0.14	1.26
QEH15CA	24	3.2	9.5	34	26	4	-	23.1	45.5	3.5	3.5	5.5	M4X5	5	5.5	5	15	12.5	7.5	5.3	4.5	60	20	M4x16	11.96	14.46	0.11	0.08	0.08	0.25	1.26
QEH20SA	28	4.6	11	42	32	5	-	29	54	4.75	5	12	M5+6	7	6	6.5	20	15.5	9.5	8.5	6	60	20	M5x16	11.46	12.14	0.11	0.04	0.04	0.21	2.09
QEH20CA	28	4.6	11	42	32	5	-	29	54	4.75	5	12	M5+6	7	6	6.5	20	15.5	9.5	8.5	6	60	20	M5x16	17.46	21.59	0.19	0.13	0.13	0.35	2.09
QEH25SA	33	4.5	12.5	48	35	6.5	-	37.5	60.5	4.75	5	12	M6+8	7.5	6	6	23	18	11	9	7	60	20	M6x20	18.81	18.98	0.2	0.09	0.09	0.37	2.69
QEH25CA	33	4.5	12.5	48	35	6.5	-	37.5	60.5	4.75	5	12	M6+8	7.5	6	6	23	18	11	9	7	60	20	M6x20	25.65	29.52	0.35	0.27	0.27	0.65	2.69
QEH30SA	42	7	16	60	40	10	-	41.5	69.5	6	5	12	M8+9	7	8	8	28	23	11	9	7	80	20	M6x25	24.88	25.96	0.36	0.15	0.15	0.64	4.26
QEH30CA	42	7	16	60	40	10	-	41.5	69.5	6	5	12	M8+9	7	8	8	28	23	11	9	7	80	20	M6x25	36.54	45.12	0.35	0.45	0.45	1.09	4.26
QEH30SA	42	7	16	60	40	10	-	41.5	69.5	6	5	12	M8+9	7	8	8	28	23	14	12	9	80	20	M8x25	24.88	25.96	0.36	0.15	0.15	0.64	4.26
QEH30CA	42	7	16	60	40	10	-	41.5	69.5	6	5	12	M8+9	7	8	8	28	23	14	12	9	80	20	M8x25	36.54	45.12	0.35	0.45	0.45	1.09	4.26

Note : 1 kgf = 9.81 N

Model with "" means guide rail with new installation hole, pls not the requirement when placing the order.

Model No.	Dimensions of Assembly (mm)		Dimensions of Block(mm)											Dimensions of Rail (mm)						Mounting Bolt for Rail (mm)	Basic Dynamic Load Rating C(KN)	Basic Static Load Rating C0(KN)	Static Rated Moment			Weight						
	H	H1	N	W	B	B1	C	L1	L	K1	K2	G	M*L	T	T1	H2	H3	WR	HR				D	h	d	P	E	Mr	Mp	My	Block kg	Rail kg/m
QEW15SA	24	3.2	18.5	52	41	5.5	-	23.1	45.5	3.5	3.5	5.5	M5	5	7	5.5	5	15	12.5	6	4.5	3.5	60	20	M3x16	8.09	8.26	0.06	0.02	0.02	0.14	1.26
QEW15CA	24	3.2	18.5	52	41	5.5	-	23.1	45.5	3.5	3.5	5.5	M5	5	7	5.5	5	15	12.5	6	4.5	3.5	60	20	M3x16	11.96	14.46	0.11	0.08	0.08	0.25	1.26
QEW15SA	24	3.2	18.5	52	41	5.5	-	23.1	45.5	3.5	3.5	5.5	M5	5	7	5.5	5	15	12.5	7.5	5.3	4.5	60	20	M4x16	8.09	8.26	0.06	0.02	0.02	0.14	1.26
QEW15CA	24	3.2	18.5	52	41	5.5	-	23.1	45.5	3.5	3.5	5.5	M5	5	7	5.5	5	15	12.5	7.5	5.3	4.5	60	20	M4x16	11.96	14.46	0.11	0.08	0.08	0.25	1.26
QEW20SA	28	4.6	19.5	59	49	5	-	29	54	4.75	5	12	M6	7	9	6	6.5	20	15.5	9.5	8.5	6	60	20	M5x16	11.46	12.14	0.11	0.04	0.04	0.21	2.09
QEW20CA	28	4.6	19.5	59	49	5	-	29	54	4.75	5	12	M6	7	9	6	6.5	20	15.5	9.5	8.5	6	60	20	M5x16	17.46	21.59	0.19	0.13	0.13	0.35	2.09
QEW25SA	33	4.5	25	73	60	6.5	-	37.5	60.5	4.75	5	12	M8	7.5	10	6	6	23	18	11	9	7	60	20	M6x20	18.81	18.98	0.2	0.09	0.09	0.37	2.69
QEW25CA	33	4.5	25	73	60	6.5	-	37.5	60.5	4.75	5	12	M8	7.5	10	6	6	23	18	11	9	7	60	20	M6x20	25.65	29.52	0.35	0.27	0.27	0.65	2.69
QEW30SA	42	7	31	90	72	9	-	41.5	69.5	6	5	12	M10	7	10	8	8	28	23	11	9	7	80	20	M6x25	24.88	25.96	0.36	0.15	0.15	0.64	4.26
QEW30CA	42	7	31	90	72	9	-	41.5	69.5	6	5	12	M10	7	10	8	8	28	23	11	9	7	80	20	M6x25	36.54	45.12	0.35	0.45	0.45	1.09	4.26
QEW30SA	42	7	31	90	72	9	-	41.5	69.5	6	5	12	M10	7	10	8	8	28	23	14	12	9	80	20	M8x25	24.88	25.96	0.36	0.15	0.15	0.64	4.26
QEW30CA	42	7	31	90	72	9	-	41.5	69.5	6	5	12	M10	7	10	8	8	28	23	14	12	9	80	20	M8x25	36.54	45.12	0.35	0.45	0.45	1.09	4.26

Note : 1 kgf = 9.81 N

Model with "" means guide rail with new installation hole, pls not the requirement when placing the order.

Linear Guideways

(3) QEW-CB / QEW-SB

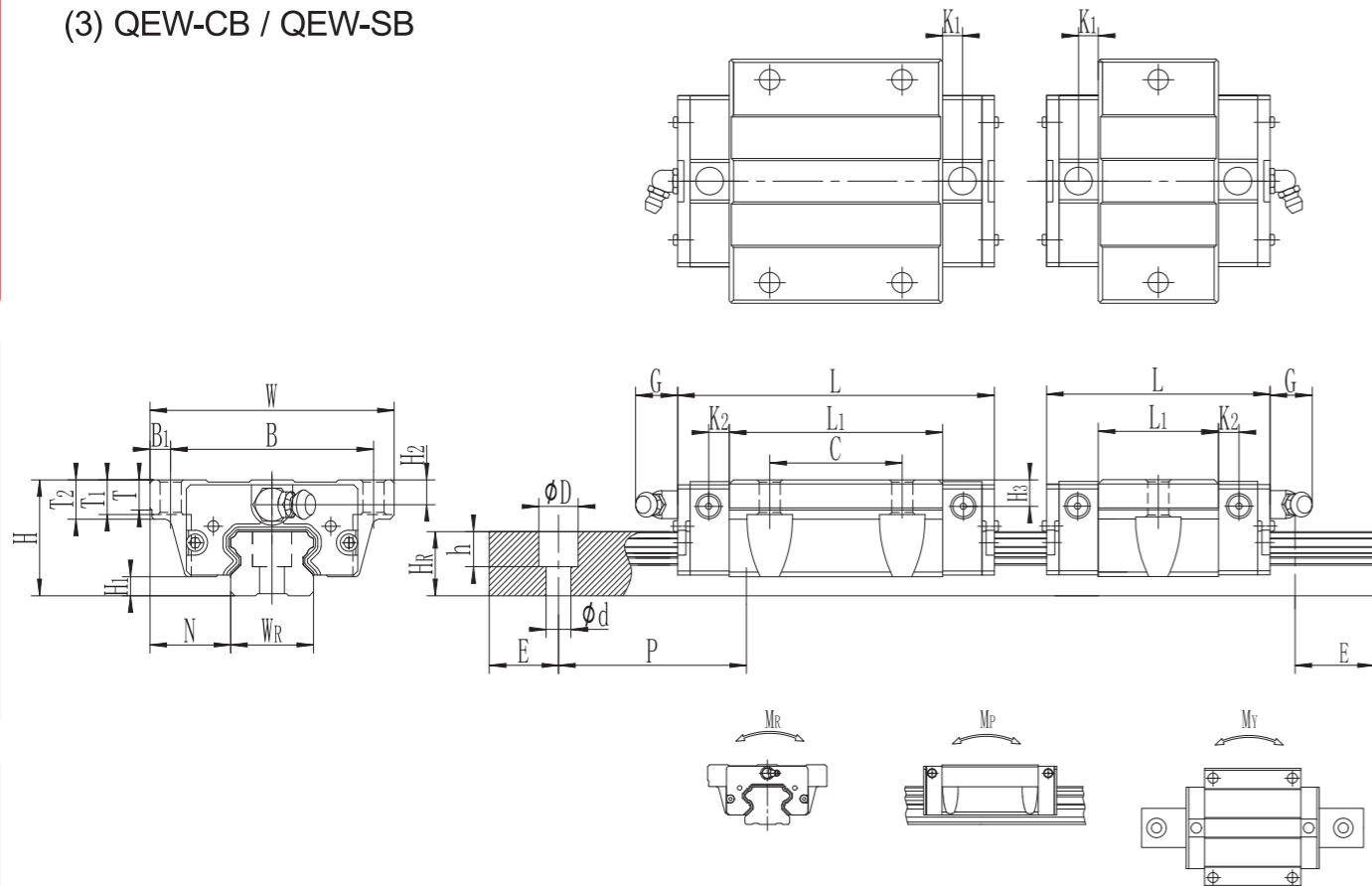

Ball Screw

Support

Linear Bushing

Model No.	Dimensions of Assembly (mm)		Dimensions of Block(mm)														Dimensions of Rail (mm)										Mounting Bolt for Rail (mm)	Basic Dynamic Load Rating C(KN)	Basic Static Load Rating C0(KN)	Static Rated Moment			Block kg	Rail kg/m
	H	H1	N	W	B	B1	C	L1	L	K1	K2	G	M*L	T	T1	T2	H2	H3	Wr	Hr	D	h	d	P	E	Mr KN-m				Mp KN-m	My KN-m			
★ QEW15SB	24	3.2	18.5	52	41	5.5	-	23.1	45.5	3.5	3.5	5.5	φ4.5	5	7	7.8	5.5	5	15	12.5	6	4.5	3.5	60	20	M3×16	8.09	8.26	0.06	0.02	0.02	0.14	1.26	
QEW15CB							26	39.8	62.2																									
QEW15SB	24	3.2	18.5	52	41	5.5	-	23.1	45.5	3.5	3.5	5.5	φ4.5	5	7	7.8	5.5	5	15	12.5	7.5	5.3	4.5	60	20	M4×16	8.09	8.26	0.06	0.02	0.02	0.14	1.26	
QEW15CB							26	39.8	62.2																									
QEW20SB	28	4.6	19.5	59	49	5	-	29	54	4.75	5	12	φ5.5	7	7	9	6	6.5	20	15.5	9.5	8.5	6	60	20	M5×16	11.46	12.14	0.11	0.04	0.04	0.21	2.09	
QEW20CB							32	51.5	76.5																									
QEW25SB	33	4.5	25	73	60	6.5	-	37.5	60.5	4.75	5	12	φ7	7.5	10	10	6	6	23	18	11	9	7	60	20	M6×20	18.81	18.98	0.2	0.09	0.09	0.37	2.69	
QEW25CB							35	59.5	82.5																									
★ QEW30SB	42	7	31	90	72	9	-	41.5	69.5	6	5	12	φ9	7	10	10	8	8	28	23	11	9	7	80	20	M6×25	24.88	25.96	0.36	0.15	0.15	0.64	4.26	
QEW30CB							40	70	98																									
QEW30SB	42	7	31	90	72	9	-	41.5	69.5	6	5	12	φ9	7	10	10	8	8	28	23	14	12	9	80	20	M8×25	24.88	25.96	0.36	0.15	0.15	0.64	4.26	
QEW30CB							40	70	98																									

Note : 1 kgf = 9.81 N

Model with "*" means guide rail with new installation hole, pls not the requirement when placing the order.

2-5 R Series – High Rigidity Roller Type Linear Guideway

2-5-1 Advantages and Features of R Series

The new R series from LIMON features a roller as the rolling element instead of steel balls. The roller series offers super high rigidity and very high load capacities. The R series is designed with a 45-degree angle of contact. Elastic deformation of the linear contact surface, during load, is greatly reduced thereby offering greater rigidity and higher load capacities in all 4 load directions. The R series linear guideway offers high performance for high-precision manufacturing and achieving longer service life.

(1) Optimal design

FEM analysis was performed to determine the optimal structure of the block and the rail. The unique design of the circulation path allows the R series linear guideway to offer smoother linear motion.

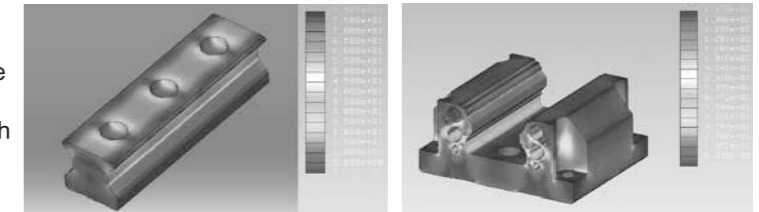

(2) Super high rigidity

The R series is a type of linear guideway that uses rollers as the rolling elements. Rollers have a greater contact area than balls so that the roller guideway features higher load capacity and greater rigidity. The figure shows the rigidity of a roller and a ball with equal volume.

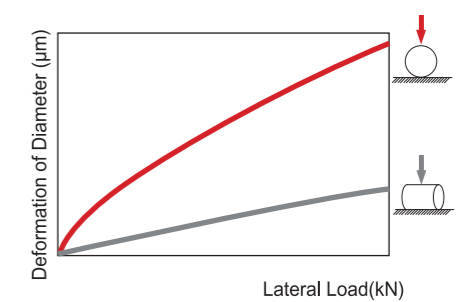

(3) Super high load capacity

With the four rows of rollers arranged at a contact angle of 45-degrees, the R series linear guideway has equal load ratings in the radial, reverse radial and lateral directions. The R series has a higher load capacity in a smaller size than conventional, ball-type linear guideways.

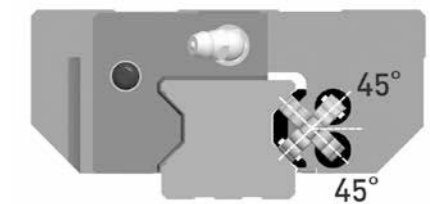

(4) Operating life increased

Compare with the ball element, the contact pressure of rolling element is distributed on the line region. Therefore, stress concentration was reduced significantly and the R series offers longer running life. The nominal life of R series can be calculated by using Eq.

2-5-2 Construction of R Series

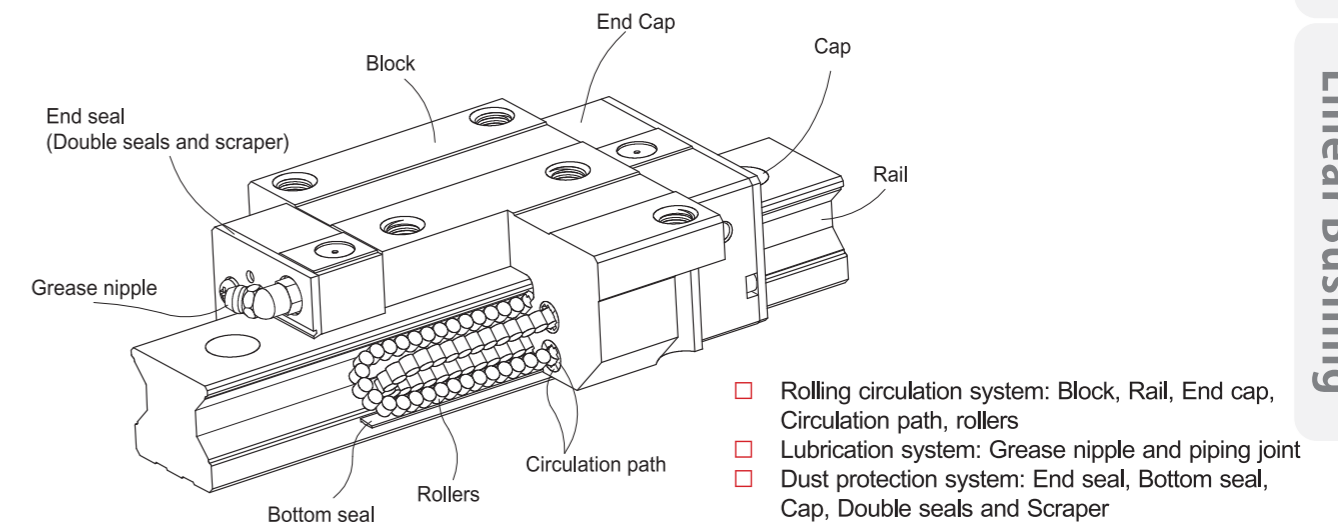

Linear Guideways

Ball Screw

Support

Linear Bushing

2-5-3 Model Number of R series

R series linear guideways are classified into non-interchangeable and interchangeable types. The sizes of these two types are the same as one another. The main difference is that the interchangeable type of blocks and rails can be freely exchanged and they can maintain P-class accuracy. Because of strict dimensional control, the interchangeable type linear guideways are a wise choice for customers when rails do not need to be matched for an axis. The model number of the R series identifies the size, type, accuracy class, preload class, etc.

(1) Non-interchangeable type

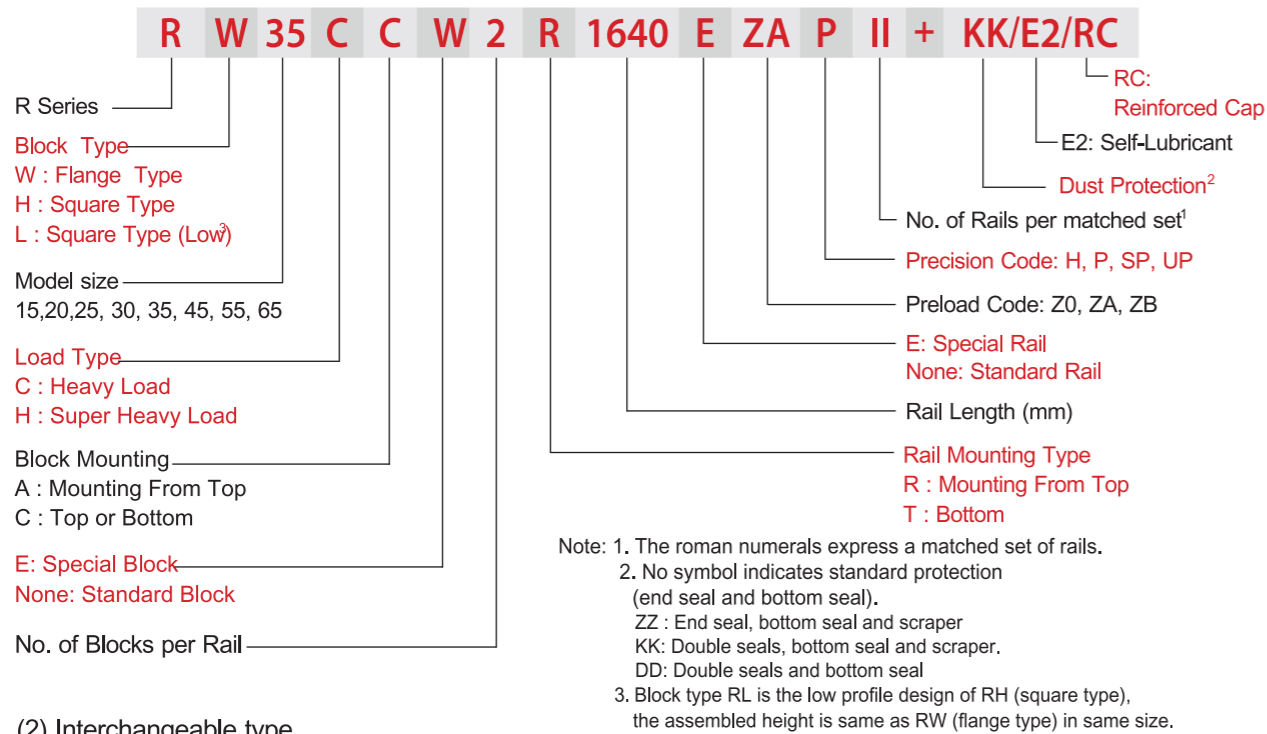

(2) Interchangeable type

□ Model Number of R Block

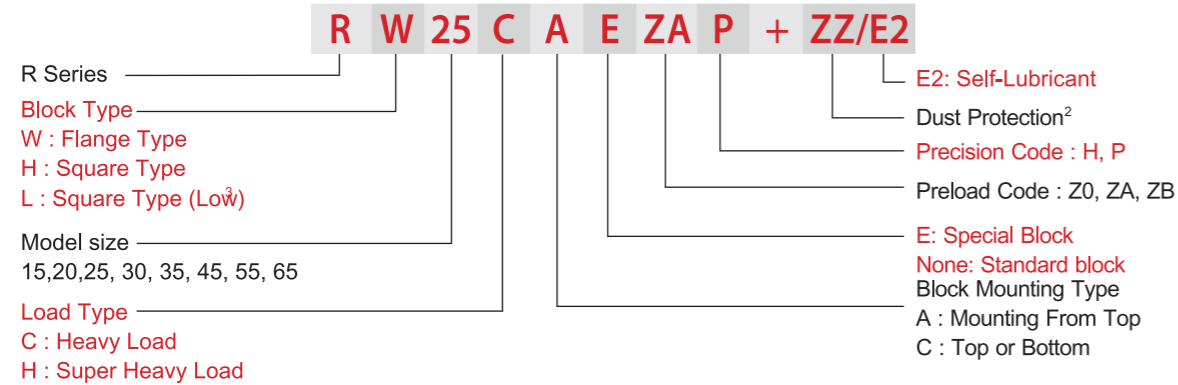

□ Model Number of R Rail

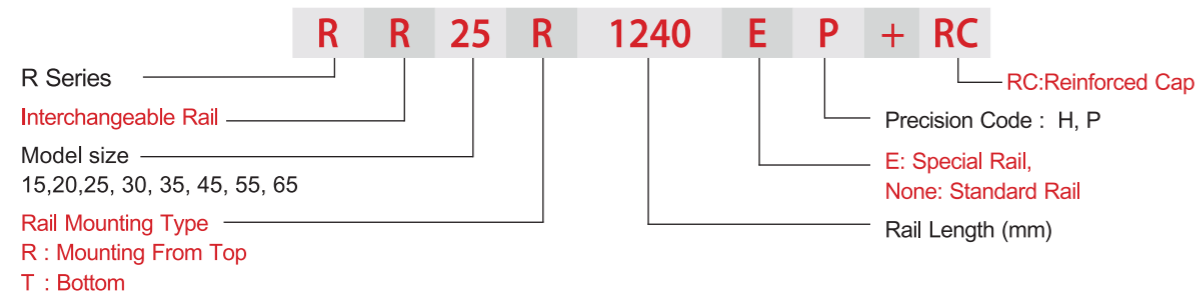

2-5-4 Types

(1) Block types

LIMON offers two types of guide blocks, flange and square type. Because of the low assembly height and large mounting surface, the flange type is excellent for heavy moment load applications.

Table 2-5-1 Block Types

Type	Model	Shape	Height (mm)	Rail Length (mm)	Main Applications
Square	RH-CA RH-HA		28	100	<input type="checkbox"/> Automation Systems <input type="checkbox"/> Transportation equipment <input type="checkbox"/> CNC machining centers <input type="checkbox"/> Heavy duty cutting machines <input type="checkbox"/> CNC grinding machines
			90	4000	
Square	RL-CA RL-HA		24	100	<input type="checkbox"/> Injection molding machines <input type="checkbox"/> Plano millers <input type="checkbox"/> Devices requiring high rigidity <input type="checkbox"/> Devices requiring high load capacity
			70	4000	
Flange	RW-CC RW-HC		24	100	<input type="checkbox"/> Electric discharge machines
			90	4000	

(2) Rail types

In addition to the standard top mounting type, LIMON also offers the bottom mounting type of rails.

Table 2-5-2 Rail Types



2-5-5 Accuracy

The accuracy of the R series can be classified into four classes: high (H), precision (P), super precision (SP) and ultra precision (UP). Customers may choose the class by referencing the accuracy requirements of the applied equipment.

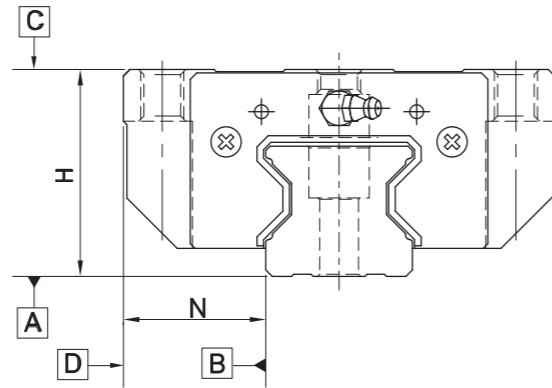

(1) Accuracy of non-interchangeable

Table 2-5-3 Accuracy Standards

Unit: mm

Item	R - 15, 20			
	High (H)	Precision (P)	Super Precision (SP)	Ultra Precision (UP)
Dimensional tolerance of height H	± 0.03	0 - 0.03	0 - 0.015	0 - 0.008
Dimensional tolerance of width N	± 0.03	0 - 0.03	0 - 0.015	0 - 0.008
Variation of height H	0.01	0.006	0.004	0.003
Variation of width N	0.01	0.006	0.004	0.003
Running parallelism of block surface C to surface A	See Table 2-5-11			
Running parallelism of block surface D to surface B	See Table 2-5-11			

Table 2-5-4 Accuracy Standards

Unit: mm

Item	R - 25, 30, 35			
	High (H)	Precision (P)	Super Precision (SP)	Ultra Precision (UP)
Dimensional tolerance of height H	± 0.04	0 - 0.04	0 - 0.02	0 - 0.01
Dimensional tolerance of width N	± 0.04	0 - 0.04	0 - 0.02	0 - 0.01
Variation of height H	0.015	0.007	0.005	0.003
Variation of width N	0.015	0.007	0.005	0.003
Running parallelism of block surface C to surface A	See Table 2-5-11			
Running parallelism of block surface D to surface B	See Table 2-5-11			

Table 2-5-5 Accuracy Standards

Unit: mm

Item	R - 45, 55			
	High (H)	Precision (P)	Super Precision (SP)	Ultra Precision (UP)
Dimensional tolerance of height H	± 0.05	0 - 0.05	0 - 0.03	0 - 0.02
Dimensional tolerance of width N	± 0.05	0 - 0.05	0 - 0.03	0 - 0.02
Variation of height H	0.015	0.007	0.005	0.003
Variation of width N	0.02	0.01	0.007	0.005
Running parallelism of block surface C to surface A	See Table 2-5-11			
Running parallelism of block surface D to surface B	See Table 2-5-11			

Table 2-5-6 Accuracy Standards

Unit: mm

Item	R - 65			
	High (H)	Precision (P)	Super Precision (SP)	Ultra Precision (UP)
Dimensional tolerance of height H	± 0.07	0 - 0.07	0 - 0.05	0 - 0.03
Dimensional tolerance of width N	± 0.07	0 - 0.07	0 - 0.05	0 - 0.03
Variation of height H	0.02	0.01	0.007	0.005
Variation of width N	0.025	0.015	0.01	0.007
Running parallelism of block surface C to surface A	See Table 2-5-11			
Running parallelism of block surface D to surface B	See Table 2-5-11			

(2) Accuracy of interchangeable

Table 2-5-7 Accuracy Standards

Unit: mm

Item	R - 15, 20	
	High (H)	Precision (P)
Dimensional tolerance of height H	± 0.03	± 0.015
Dimensional tolerance of width N	± 0.03	± 0.015
Variation of height H	0.01	0.006
Variation of width N	0.01	0.006
Running parallelism of block surface C to surface A	See Table 2-5-11	
Running parallelism of block surface D to surface B	See Table 2-5-11	

Table 2-5-8 Accuracy Standards

Unit: mm

Item	R - 25, 30, 35	
	High (H)	Precision (P)
Dimensional tolerance of height H	± 0.04	± 0.02
Dimensional tolerance of width N	± 0.04	± 0.02
Variation of height H	0.015	0.007
Variation of width N	0.015	0.007
Running parallelism of block surface C to surface A	See Table 2-5-11	
Running parallelism of block surface D to surface B	See Table 2-5-11	

Table 2-5-9 Accuracy Standards

Unit: mm

Item	R - 45, 55	
	High (H)	Precision (P)
Dimensional tolerance of height H	± 0.05	± 0.025
Dimensional tolerance of width N	± 0.05	± 0.025
Variation of height H	0.015	0.007
Variation of width N	0.02	0.01
Running parallelism of block surface C to surface A	See Table 2-5-11	
Running parallelism of block surface D to surface B	See Table 2-5-11	

Table 2-5-10 Accuracy Standards

Item	R - 65	
	High (H)	Precision (P)
Dimensional tolerance of height H	± 0.07	± 0.035
Dimensional tolerance of width N	± 0.07	± 0.035
Variation of height H	0.02	0.01
Variation of width N	0.025	0.015
Running parallelism of block surface C to surface A	See Table 2-5-11	
Running parallelism of block surface D to surface B	See Table 2-5-11	

Unit: mm

(3) Accuracy of running parallelism

Table 2-5-11 Accuracy of Running Parallelism

Rail Length (mm)	Accuracy (μm)			
	H	P	SP	UP
~ 100	7	3	2	2
100 ~ 200	9	4	2	2
200 ~ 300	10	5	3	2
300 ~ 500	12	6	3	2
500 ~ 700	13	7	4	2
700 ~ 900	15	8	5	3
900 ~ 1,100	16	9	6	3
1,100 ~ 1,500	18	11	7	4
1,500 ~ 1,900	20	13	8	4
1,900 ~ 2,500	22	15	10	5
2,500 ~ 3,100	25	18	11	6
3,100 ~ 3,600	27	20	14	7
3,600 ~ 4,000	28	21	15	7

2-5-6 Preload

A preload can be applied to each guideway using oversized rollers. Generally, a linear motion guideway has negative clearance between the raceway and rollers to improve stiffness and maintain high precision. The R series linear guideway offers three standard preloads for various applications and conditions.

Table 2-5-12

Class	Code	Preload	Condition
Light Preload	Z0	0.02C~ 0.04C	Certain load direction, low impact, low precision required
Medium Preload	ZA	0.07C~0.09C	High rigidity required, high precision required
Heavy Preload	ZB	0.12C~ 0.14C	Super high rigidity required, with vibration and impact

The figure shows the relationship between the rigidity, friction and nominal life. A preload no larger than ZA would be recommended for smaller model sizes to avoid over-preload affecting the life of the guideway.

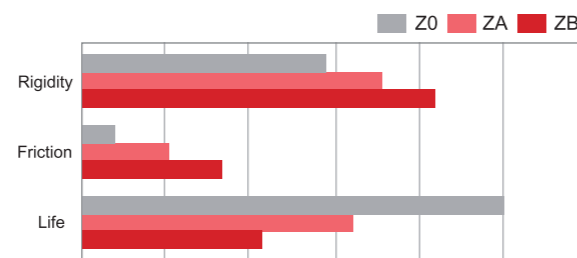

2-5-7 Lubrication

(1) Grease

- Grease nipple

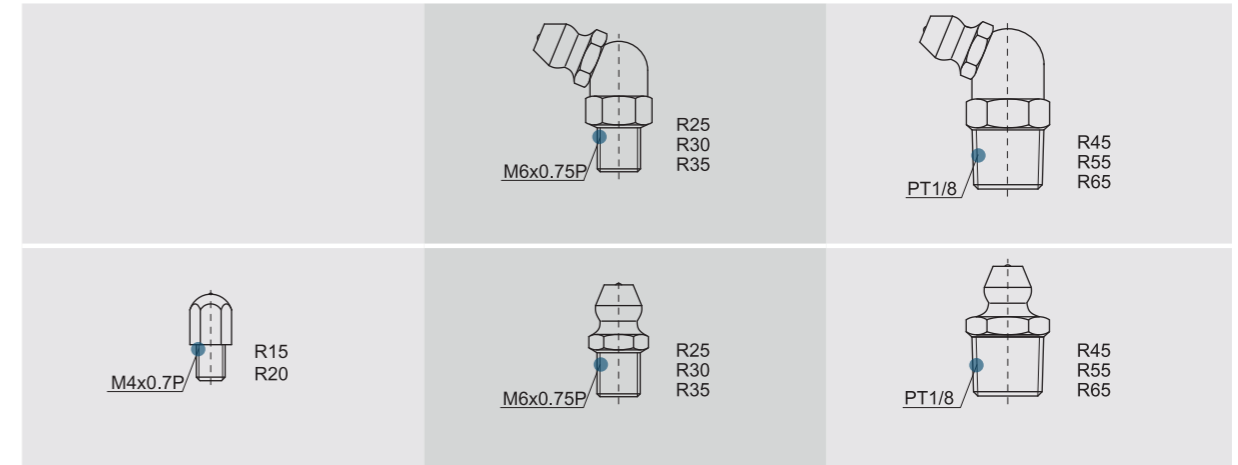

- Mounting location

The standard location of the grease fitting is at both ends of the block, but the nipple can be mounted in the side or the top of block. For lateral installation, we recommend that the nipple be mounted at the non-reference side, otherwise please contact us. It is possible to carry out the lubrication by using an oil-piping joint. The figure shows the locations of the grease fitting.

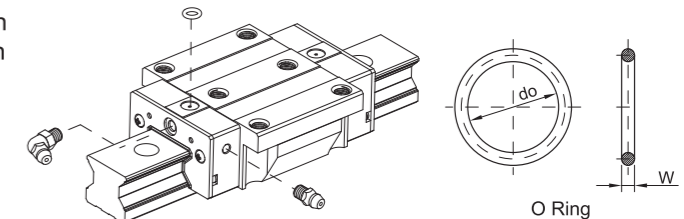
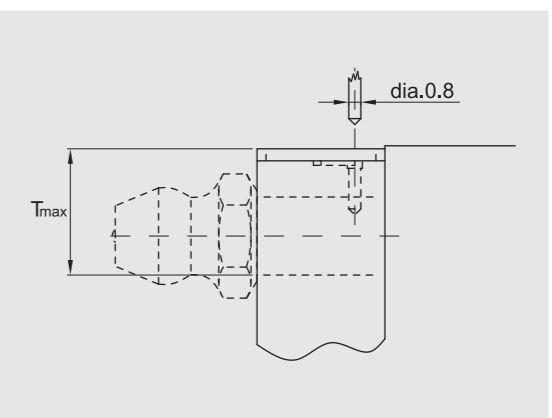

Table 2-5-13 O-Ring size and max. permissible depth for piercing

Size	O-Ring		Lube hole at top: max. permissible depth for piercing
	do (mm)	W (mm)	T _{max} (mm)
R15	2.5±0.15	1.5±0.15	3.45
R20	2.5±0.15	1.5±0.15	4
R25	7.5±0.15	1.5±0.15	5.8
R30	7.5±0.15	1.5±0.15	6.2
R35	7.5±0.15	1.5±0.15	8.65
R45	7.5±0.15	1.5±0.15	9.5
R55	7.5±0.15	1.5±0.15	11.6
R65	7.5±0.15	1.5±0.15	14.5



- The oil amount for a block filled with grease

Table 2-5-14 The oil amount for a block filled with grease

Size	Heavy Load(cm ³)	Super Heavy Load(cm ³)	Size	Heavy Load(cm ³)	Super Heavy Load(cm ³)
R15	3	-	R35	12	14
R20	5	6	R45	19	23
R25	7	8	R55	28	35
R30	9	10	R65	52	63

Frequency of replenishment

Check the grease every 100 km, or every 3-6 months.

(2) Oil

The recommended viscosity of oil is about 32~150cSt. If you need to use oil-type lubrication, please inform us.

Oil feeding rate

Table 2-5-15 oil feed rate

Size	Feed rate (cm ³ /hr)
R15	0.14
R20	0.14
R25	0.167
R30	0.2
R35	0.23
R45	0.3
R55	0.367
R65	0.433

2-5-8 Dust Proof Accessories

(1) Codes of accessories

If the following accessories are needed, please add the code followed by the model number.

Table 2-5-16

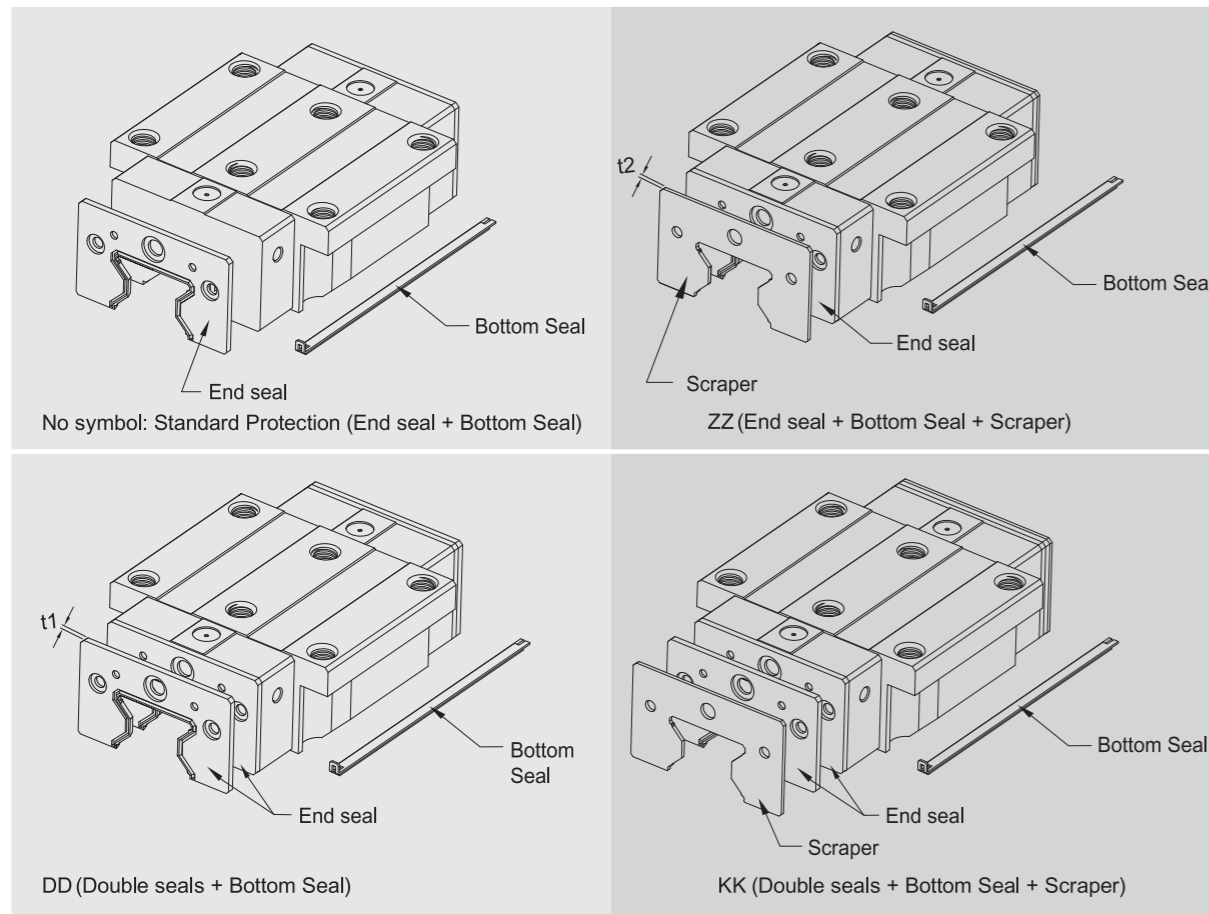

(2) End seal and bottom seal

To prevent life reduction caused by iron chips or dust entering the block.

(3) Double seals

Enhances the wiping effect, foreign matter can be completely wiped off.

Table 2-5-17 Dimensions of end seal

Size	Thickness (t1) (mm)	Size	Thickness (t1) (mm)
R15 ES	2.2	R35 ES	2.5
R20 ES	2.2	R45 ES	3.6
R25 ES	2.2	R55 ES	3.6
R30 ES	2.4	R65 ES	4.4

(4) Scraper

The scraper removes high-temperature iron chips and larger foreign objects.

Table 2-5-18 Dimensions of scraper

Size	Thickness (t2) (mm)	Size	Thickness (t2) (mm)
R15 SC	1.0	R35 SC	1.5
R20 SC	1.0	R45 SC	1.5
R25 SC	1.0	R55 SC	1.5
R30 SC	1.5	R65 SC	1.5

(5) Bolt caps for rail mounting holes

Caps are used to cover the mounting holes to prevent chips or other foreign objects from collecting in the holes. The caps will be enclosed in each rail package.



Table 2-5-19 Dimensions of Bolt Caps for Rail Mounting Holes

Rail size	Bolt size	Diameter(D) (mm)	Thickness(H) (mm)	Rail size	Bolt size	Diameter(D) (mm)	Thickness(H) (mm)
RR 15	M4	7.65	1.1	RR 35	M8	14.2	3.3
RR 20	M5	9.65	2.2	RR 45	M12	20.25	4.6
RR 25	M6	11.15	2.5	RR 55	M14	23.5	5.5
RR 30	M8	14.2	3.3	RR 65	M16	26.6	5.5

(6) Dimensions of block equipped with the dustproof parts

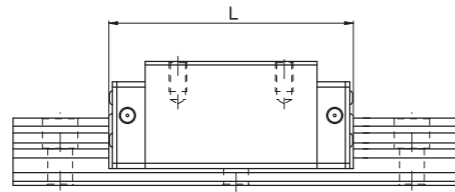

Table 2-5-20 Overall block length

unit: mm

Size	Overall block length (L)			
	SS	ZZ	DD	KK
R15C	68.0 (70.4)	70.0 (74.4)	72.4 (74.8)	74.4 (78.8)
R20C	86.0 (88.4)	88.0 (92.4)	90.4 (92.8)	92.4 (96.8)
R20H	106.0 (108.4)	108.0 (112.4)	110.4 (112.8)	112.4 (116.8)
R25C	97.9 (101.5)	99.9 (105.9)	102.3 (105.9)	104.3 (110.3)
R25H	114.4 (118)	116.4 (122.4)	118.8 (122.4)	120.8 (126.8)
R30C	109.8 (113.4)	112.8 (118.8)	114.6 (118.2)	117.6 (123.6)
R30H	131.8 (135.4)	134.8 (140.8)	136.6 (140.2)	139.6 (145.6)
R35C	124.0 (129.4)	127.0 (135.0)	129.0 (134.4)	132.0 (140.0)
R35H	151.5 (156.9)	154.5 (162.5)	156.5 (161.9)	159.5 (167.5)
R45C	153.2 (156.4)	156.2 (164.2)	160.4 (163.6)	163.4 (171.4)
R45H	187.0 (190.2)	190.0 (198.0)	194.2 (197.4)	197.2 (205.2)
R55C	183.7 (186.9)	186.7 (194.7)	190.9 (194.1)	193.9 (201.9)
R55H	232.0 (235.2)	235.0 (243.0)	239.2 (242.4)	242.2 (250.2)
R65C	232.0 (236.0)	235.0 (245.0)	240.8 (244.8)	243.8 (253.8)
R65H	295.0 (299.0)	298.0 (308.0)	303.8 (307.8)	306.8 (316.8)

Note : The marking of "()" denotes the maximum block length with screws, lips of end seals, etc.

2-5-9 Friction

The maximum value of resistance per end seal are as shown in the table.

Table 2-5-21 Seal Resistance

Size	Resistance N (kgf)	Size	Resistance N (kgf)
R15	1.96 (0.2)	R35	3.53 (0.36)
R20	2.45 (0.25)	R45	4.21 (0.43)
R25	2.74 (0.28)	R55	5.09 (0.52)
R30	3.31 (0.31)	R65	6.66 (0.68)

2-5-10 Dimensions for R series

(1) RH-SA/RH-CA/RH-HA

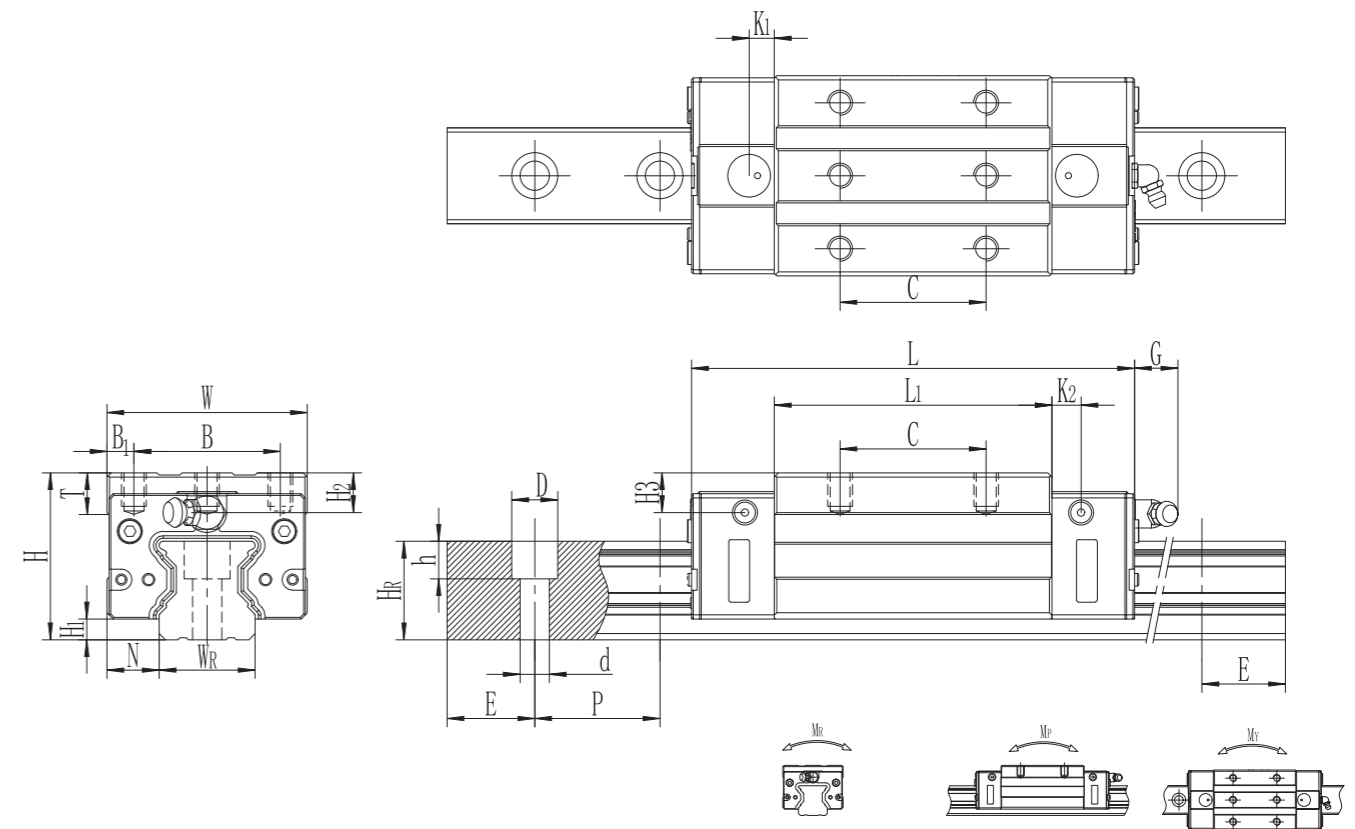

Model No.	Dimensions of Assembly (mm)			Dimensions of Block(mm)																Dimensions of Rail (mm)				Mounting Bolt for Rail (mm)	Basic Dynamic Load Rating C(KN)	Basic Static Load Rating C0(KN)	Static Rated Moment			Weight		
	H	H1	N	W	B	B1	C	L1	L	K1	K2	G	M*L	T	H2	H3	WR	HR	D	h	d	P	E				C(KN)	C0(KN)	MR KN-m	MP KN-m	MY KN-m	Block kg
RH25SA							35	55.1	96.3																28.54	50.21	0.78	0.65	0.65	0.53		
RH25CA	40	5	12.5	48	35	6.5		66.5	107.7	6	7	12	M6X10	10	9.5	9.5	23	23.6	11	9	7	30	20	M6X25	33.35	61.37	0.89	0.80	0.80	0.64	3.12	
RH25HA							50	83	124.2																39.13	75.31	1.12	1.15	1.15	0.78		
RH30CA	45	6	16	60	40	10		40	71	114	8	8	12	M8X10	9.5	9.5	10.3	28	28	14	12	9	40	20	M8X30	48.62	81.29	1.8	1.55	1.55	0.92	4.47
RH30HA							60	93	136																61.45	109.98	2.05	1.92	1.92	1.21		
RH35CA	55	6.5	18	70	50	10		50	82	131	8	12	12	M8X14	12	16	16	34	30.2	14	12	9	40	20	M8X30	55.14	95.64	2.01	1.22	1.22	1.6	6.13
RH35HA							72	110	159																69.62	129.11	2.66	2.3	2.3	2.1		
RH45CA	70	8	20.5	86	60	13		60	106	158	8	10	13	M10X20	16	20	20	45	38	20	17	14	52.5	22.5	M12X35	95.63	178.72	4.75	3.55	3.55	3.2	9.99
RH45HA							80	142	194																120.6	240.89	6.55	5.8	5.8	4.19		
RH55CA	80	10	23.5	100	75	12.5		75	125.5	182.5	8	12.5	13	M12X20	19	22	22	53	44	23	20	16	60	30	M14X45	147.64	255.03	8.2	5.6	5.6	4.92	14.14
RH55HA							95	176.5	233.5																196.95	369.8	11.25	10.4	10.4	6.72		
RH65CA	90	12	31.5	126	76	25		70	160	232	16	16	13	M16X20	25	15	15	63	53	26	22	18	75.0	35.0	M16X50	213	411.6	16.2	11.59	11.59	8.89	20.3
RH65HA							120	223	295																	275.3	572.7	22.55	22.17	22.17	12.13	

Note : 1. 1 kgf = 9.81 N

2. The theoretical dynamic rated load is C_{100R}, if necessary C_{50R} conversion formula is as follows : C_{50R} = 1.23 x C_{100R}

(2) RL-SA/RL-CA/RL-HA

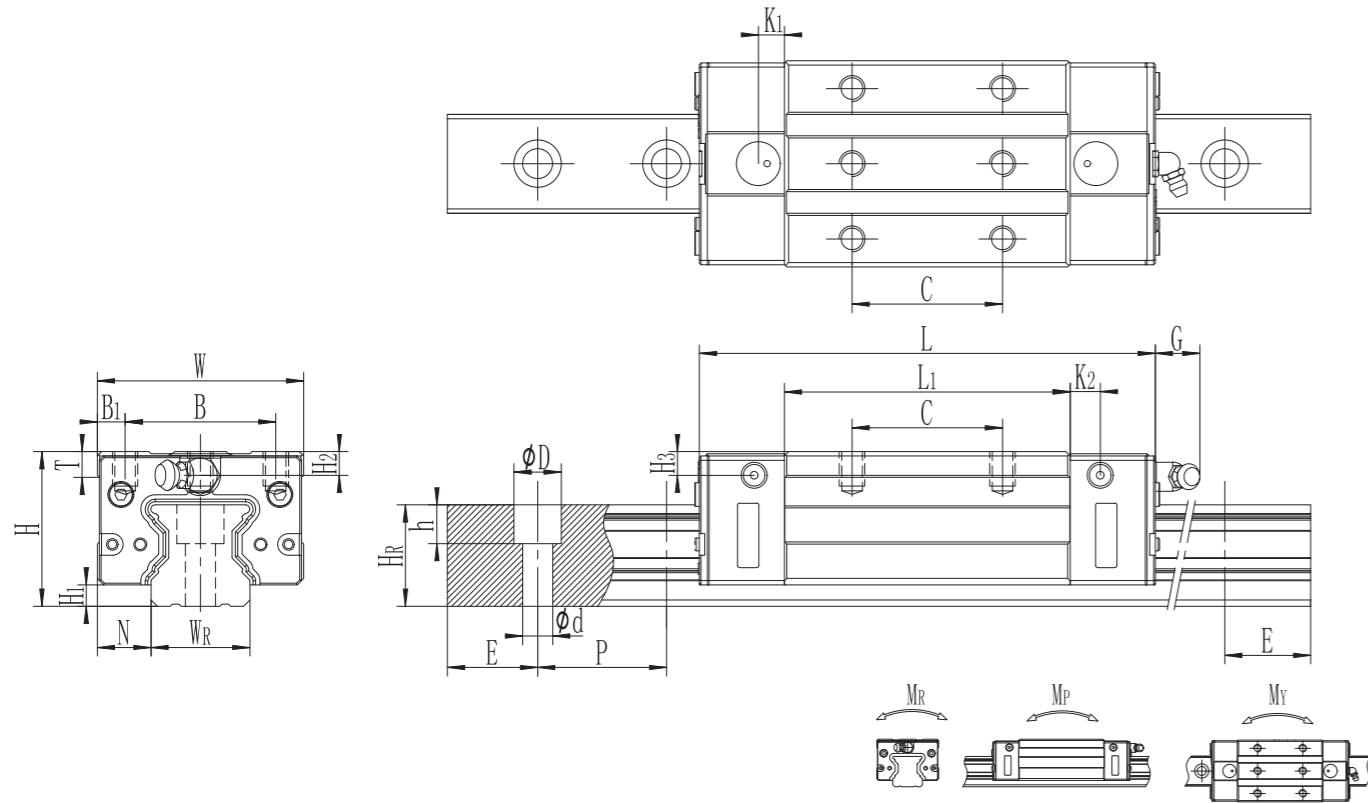

(3) RW-SC/RW-CC/RW-HC

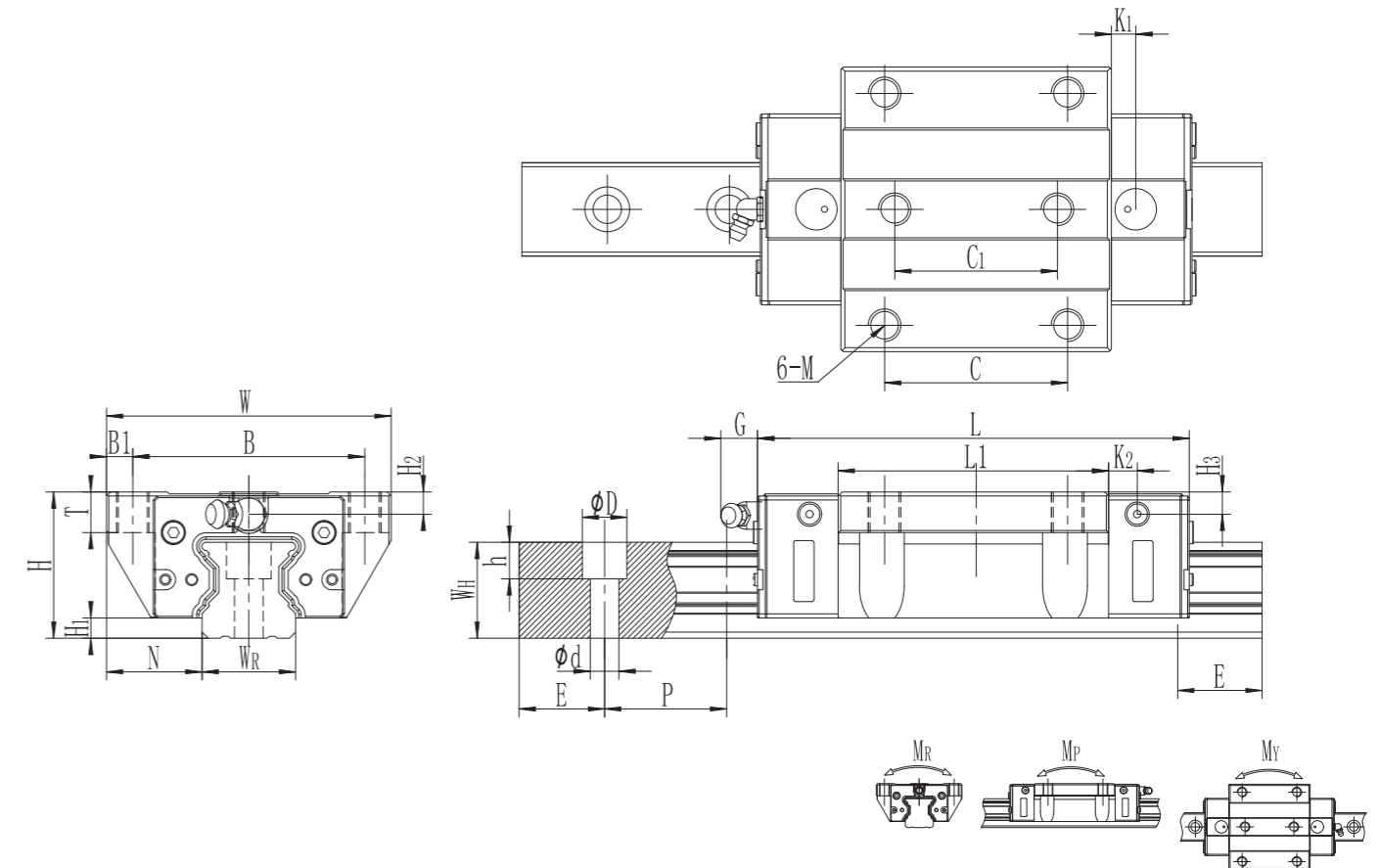

Model No.	Dimensions of Assembly (mm)			Dimensions of Block(mm)										Dimensions of Rail (mm)										Mounting Bolt for Rail (mm)	Basic Dynamic Load Rating C(KN)	Basic Static Load Rating CO(KN)	Static Rated Moment			Weight					
	H	H ₁	N	W	B	B ₁	C	L ₁	L	K ₁	K ₂	G	M	L	T	H ₂	H ₃	W _R	H _R	D	h	d	P				E	M _R (KN-m)	M _P (KN-m)	M _Y (KN-m)	Block (kg)	Rail (kg/m)			
RL25SA							35	55.1	96.3																			28.54	50.21	0.78	0.65	0.65	0.53		
RL25CA	36	5	12.5	48	35	6.5		66.5	107.7	6	7	12	M6X10	10	5.5	5.5	23	23.6	11	9	7	30	20			M6X25	33.35	61.37	0.89	0.80	0.80	0.64	3.12		
RL25HA							50	83	124.2																			39.13	75.31	1.12	1.15	1.15	0.78		
RL30CA	42	6	16	60	40	10		40	71	114	8	8	12	M8X10	9.5	6.5	7.3	28	28	14	12	9	40	20		M8X30	48.62	81.29	1.8	1.55	1.55	0.92	4.47		
RL30HA							60	93	136																			61.45	109.98	2.05	1.92	1.92	1.21		
RL35CA	48	6.5	18	70	50	10		50	82	131	8	12	12	M8X14	12	9	9	34	30.2	14	12	9	40	20		M8X30	55.14	95.64	2.01	1.22	1.22	1.6	6.13		
RL35HA							72	110	159																			69.62	129.11	2.66	2.3	2.3	2.1		
RL45CA	60	8	20.5	86	60	13		60	106	158	8	10	13	M10X17	16	10	10	45	38	20	17	14	52.5	22.5		M12X35	95.63	178.72	4.75	3.55	3.55	3.2	9.99		
RL45HA							80	142	194																			120.6	240.89	6.55	5.8	5.8	4.19		
RL55CA	70	10	23.5	100	75	12.5		75	125.5	182.5	8	12.5	13	M12X20	19	12	12	53	44	23	20	16	60	30		M14X45	147.64	255.03	8.2	5.6	5.6	4.92	14.14		
RL55HA							95	176.5	233.5																			196.95	369.8	11.25	10.4	10.4	6.72		

Note : 1. 1 kgf = 9.81 N

2. The theoretical dynamic rated load is C_{100R}, if necessary C_{50R} conversion formula is as follows : C_{50R} = 1.23 x C_{100R}

Model No.	Dimensions of Assembly (mm)			Dimensions of Block(mm)										Dimensions of Rail (mm)										Mounting Bolt for Rail (mm)	Basic Dynamic Load Rating C(KN)	Basic Static Load Rating CO(KN)	Static Rated Moment			Weight					
	H	H ₁	N	W	B	B ₁	C	C ₁	L ₁	L	K ₁	K ₂	G	M	T	T ₁	H ₂	H ₃	W _R	H _R	D	h	d				P	E	M _R (KN-m)	M _P (KN-m)	M _Y (KN-m)	Block (kg)	Rail (kg/m)		
RW25SC										55.1	96.3																	28.54	50.21	0.78	0.65	0.65	0.53		
RW25CC	36	5	23.5	70	57	6.5	45	40	66.5	107.7	6	7	12	M8	10	12.5	5.5	5.5	23	23.6	11	9	7	30	20		M6X25	33.35	61.37	0.89	0.80	0.80	0.64	3.12	
RW25HC									83	124.2																		39.13	75.31	1.12	1.15	1.15	0.78		
RW30CC	42	6	31	90	72	9	52	44	71	114	8	8	12	M10	9.5	14	6.5	7.3	28	28	14	12	9	40	20		M8X30	48.62	81.29	1.8	1.55	1.55	0.92	4.47	
RW30CC									93	136																		61.45	109.98	2.05	1.92	1.92	1.21		
RW35CC	48	6.5	33	100	82	9	62	52	82	131	8	12	12	M10	12	13	9	9	34	30.2	14	12	9	40	20		M8X30	55.14	95.64	2.01	1.22	1.22	1.6	6.13	
RW35HC									110	159																		69.62	129.11	2.66	2.3	2.3	2.1		
RW45CC	60	8	37.5	120	100	10	80	60	106	158	8	10	13	M12	16	18	10	10	45	38	20	17	14	52.5	22.5		M12X35	95.63	178.72	4.75	3.55	3.55	3.2	9.99	
RW45HC									142	194																		120.6	240.89	6.55	5.8	5.8	4.19		
RW55CC	70	10	43.5	140	116	12	95	70	125.5	182.5	8	13	13	M14	18	18	12	12	53	44	23	20	16	60	30		M14X45	147.64	255.03	8.2	5.6	5.6	4.92	14.14	
RW55HC									176.5	233.5																		196.95	369.8	11.25	10.4	10.4	6.72		
RW65CC	90	12	53.5	170	142	14	110	82	160	232	16	16	13	M16	22	23	15	15	63	53	26	22	18	75	35		M16X50	213	411.6	16.2	11.59	11.59	8.89	20.3	
RW65HC									223	295																		275.3	572.7	22.55	22.17	22.17	12.13		

Note : 1. 1 kgf = 9.81 N

2. The theoretical dynamic rated load is C_{100R}, if necessary C_{50R} conversion formula is as follows : C_{50R} = 1.23 x C_{100R}

2-6 M Series - Miniature Type Linear Guideway

(1) Non-interchangeable type

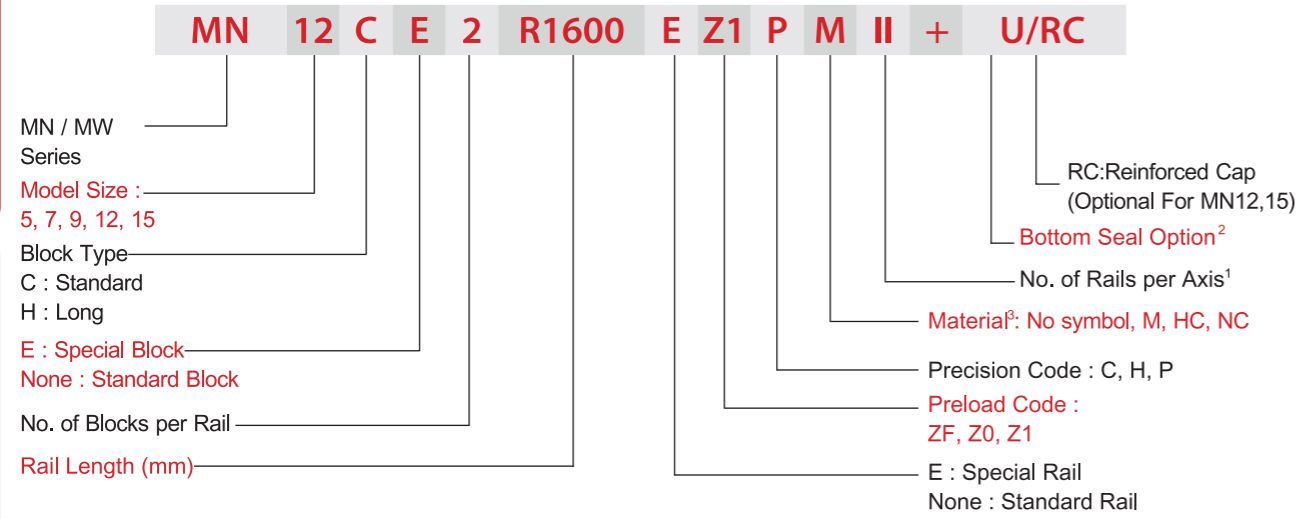

(2) Interchangeable type
 Interchangeable Block

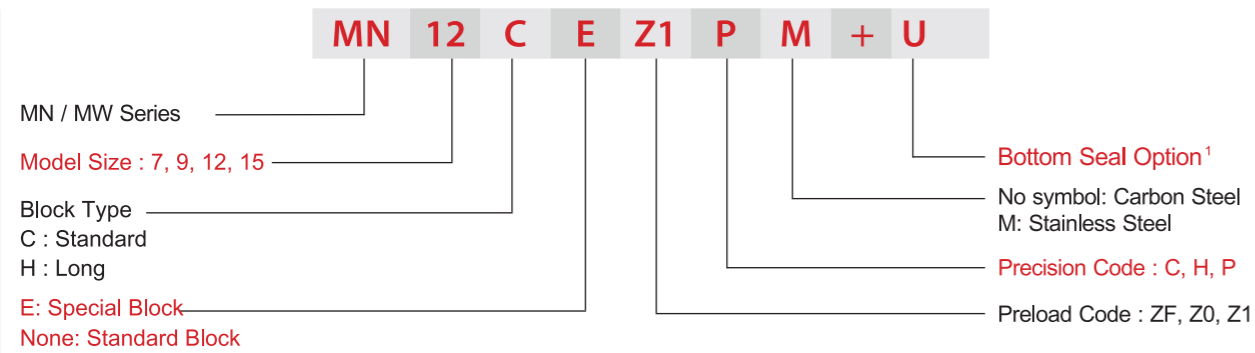

Interchangeable Rail

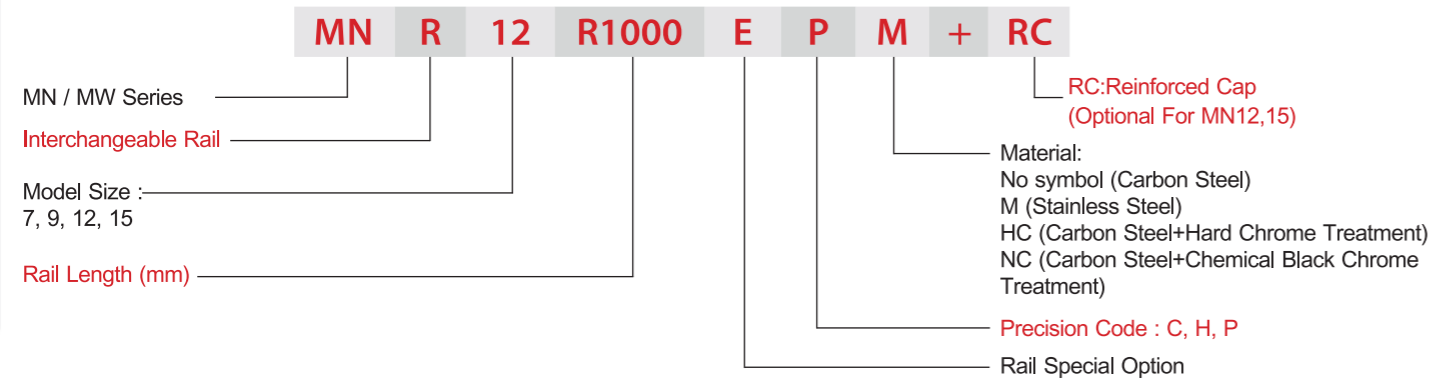

2-6-1 Types

(1) Block types

LIMON offers two types of linear guideways, standard and widen types.

Table 2-6-1 Block Types

Type	Model	Shape	Height (mm)	Rail Length (mm)	Main Applications
standard	MN-C MN-H		8	100	<input type="checkbox"/> Printer <input type="checkbox"/> Robotics <input type="checkbox"/> Precision measure equipment <input type="checkbox"/> Semiconductor equipment
			↓	↓	
widen	MW-C MW-H		9	100	
			↓	↓	
			16	2000	

*Please refer to the chapter 2-6-5 for the dimensional detail.

(2) Rail types

LIMON offers standard top mounting type.

Table 2-6-2 Rail Types

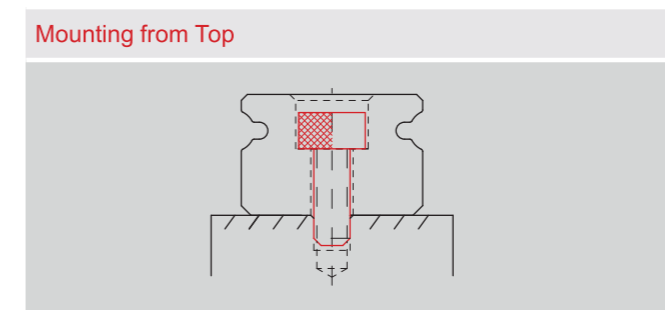

2-6-2 Accuracy

The accuracy of MN/MW series can be classified into three classes: normal (C), high (H), precision (P). Choices for different accuracy classes are available according to various requirements.

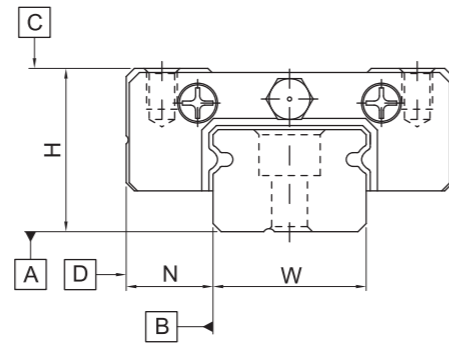

(1) Accuracy of non-interchangeable guideways

Table 2-6-3 Accuracy Standard of Non-interchangeable Type

Unit: mm

Accuracy Classes	Normal (C)	High (H)	Precision (P)
Dimensional tolerance of height H	± 0.04	± 0.02	± 0.01
Dimensional tolerance of width N	± 0.04	± 0.025	± 0.015
Pair Variation of height H	0.03	0.015	0.007
Pair Variation of width N (Master Rail)	0.03	0.02	0.01
Running parallelism of block surface C to surface A	See Table 2-6-5		
Running parallelism of block surface D to surface B	See Table 2-6-5		

(2) Accuracy of interchangeable guideways

Table 2-6-4 Accuracy Standard of Interchangeable Type

Unit: mm

Accuracy Classes	Normal (C)	High (H)	Precision (P)
Dimensional tolerance of height H	± 0.04	± 0.02	± 0.01
Dimensional tolerance of width N	± 0.04	± 0.025	± 0.015
One Set	Pair Variation of height H	0.03	0.015
	Pair Variation of width N	0.03	0.02
Pair Variation of width N (Master Rail)	0.07	0.04	0.02
Running parallelism of block surface C to surface A	See Table 2-6-5		
Running parallelism of block surface D to surface B	See Table 2-6-5		

(3) Accuracy of running parallelism

The running parallelism C to A and D to B are related to the rail length.

Table 2-6-5 Accuracy of Running Parallelism

Rail Length (mm)	Accuracy (μm)			Rail Length (mm)	Accuracy (μm)		
	(C)	(H)	(P)		(C)	(H)	(P)
~ 50	12	6	2	1,000 ~ 1,200	25	18	11
50 ~ 80	13	7	3	1,200 ~ 1,300	25	18	11
80 ~ 125	14	8	3.5	1,300 ~ 1,400	26	19	12
125 ~ 200	15	9	4	1,400 ~ 1,500	27	19	12
200 ~ 250	16	10	5	1,500 ~ 1,600	28	20	13
250 ~ 315	17	11	5	1,600 ~ 1,700	29	20	14
315 ~ 400	18	11	6	1,700 ~ 1,800	30	21	14
400 ~ 500	19	12	6	1,800 ~ 1,900	30	21	15
500 ~ 630	20	13	7	1,900 ~ 2,000	31	22	15
630 ~ 800	22	14	8	2,000 ~	31	22	16
800 ~ 1,000	23	16	9				

2-6-3 Preload

MN/MW series provides three different preload levels for various applications.

Table 2-6-6 Preload Classes

Class	Code	Preload	Accuracy
Light Clearance	ZF	Clearance 4~10μm	C
Very Light Preload	Z0	0	C~P
Light Preload	Z1	0.02C	C~P

Note: "C" in column preload means basic dynamic load rating.

2-6-4 Dust Proof Accessories

End seals and standard accessories fixed on both sides of the block can prevent dust from entering the block, so the accuracy and service life of a linear guideway can be maintained. Bottom seals are fixed under the skirt portion of the block to prevent dust from entering. Customers can order bottom seals by adding the mark "+U" followed by the model number. Sizes 9, 12 and 15 provide bottom seals as an option, but size 5, 7 do not offer the option due to the space limit of H₁. Note that "H₁" would be reduced if bottom seals are attached, be aware of possible interference between block and mounting surface.

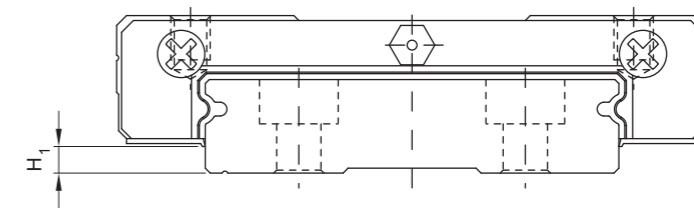

Table 2-6-7

Size	Bottom seal	H ₁ mm	Size	Bottom seal	H ₁ mm
MN 5	-	-	MW 5	-	-
MN 7	-	-	MW 7	-	-
MN 9	•	1	MW 9	•	1.9
MN 12	•	2	MW 12	•	2.4
MN 15	•	3	MW 15	•	2.4

2-6-5 Dimensions for MN/MW Series

(1) MN-C / MN-H

MN5

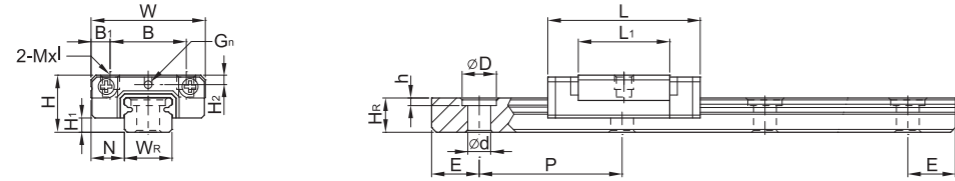

MN7, MN9, MN12

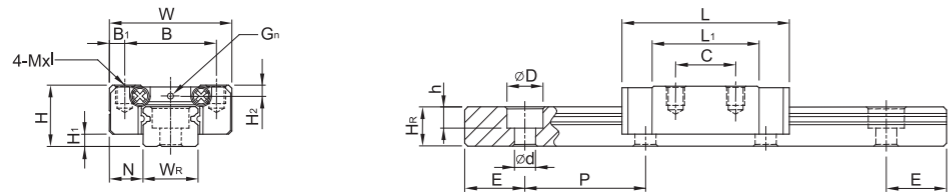

MN15

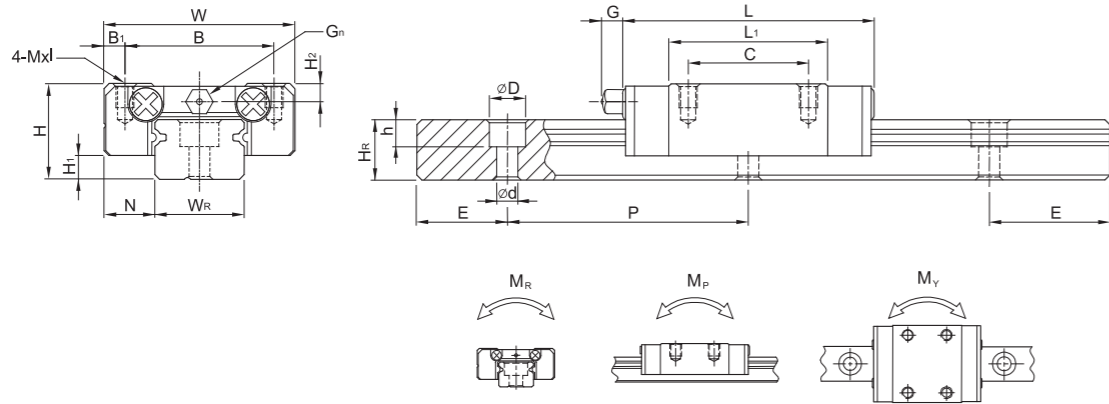

(2) MW-C / MW-H

MW7, MW9, MW12

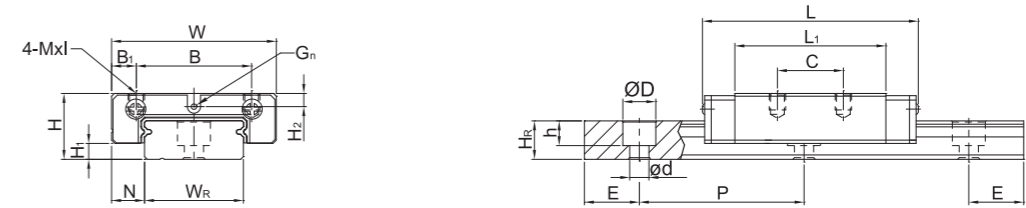

MW15

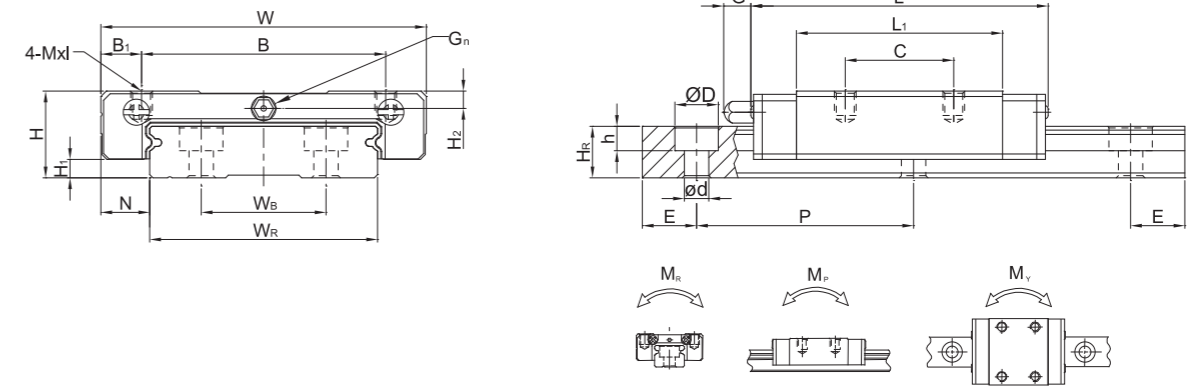

Model No.	Dimensions of Assembly (mm)			Dimensions of Block (mm)										Dimensions of Rail (mm)				Mounting Bolt for Rail (mm)	Basic Dynamic Load Rating C (kN)	Basic Static Load Rating C ₀ (kN)	Static Rated Moment			Weight				
	H	H ₁	N	W	B	B ₁	C	L ₁	L	G	G _n	MxI	H ₂	W _R	H _R	D	h				d	P	E	M _R	M _P	M _V	Block	Rail
	mm	mm	mm	mm	mm	mm	mm	mm	mm	mm	mm	mm	mm	mm	mm	mm	mm				mm	mm	mm	N-m	N-m	N-m	kg	kg/m
MN5C	6	1.5	3.5	12	8	2	-	9.6	16	-	∅0.8	M2x1.5	1	5	3.6	3.6	0.8	2.4	15	5	M2x6	0.54	0.86	2	1.3	1.3	0.008	0.15
MN7C	8	1.5	5	17	12	2.5	8	13.5	22.5	-	∅1.2	M2x2.5	1.5	7	4.8	4.2	2.3	2.4	15	5	M2x6	0.98	1.24	4.70	2.84	2.84	0.010	0.22
MN7H	8	1.5	5	17	12	2.5	13	21.8	30.8	-	∅1.2	M2x2.5	1.5	7	4.8	4.2	2.3	2.4	15	5	M2x6	1.37	1.96	7.64	4.80	4.80	0.015	0.22
MN9C	10	2	5.5	20	15	2.5	10	18.9	28.9	-	∅1.4	M3x3	1.8	9	6.5	6	3.5	3.5	20	7.5	M3x8	1.86	2.55	11.76	7.35	7.35	0.016	0.38
MN9H	10	2	5.5	20	15	2.5	16	29.9	39.9	-	∅1.4	M3x3	1.8	9	6.5	6	3.5	3.5	20	7.5	M3x8	2.55	4.02	19.60	18.62	18.62	0.026	0.38
MN12C	13	3	7.5	27	20	3.5	15	21.7	34.7	-	∅2	M3x3.5	2.5	12	8	6	4.5	3.5	25	10	M3x8	2.84	3.92	25.48	13.72	13.72	0.034	0.65
MN12H	13	3	7.5	27	20	3.5	20	32.4	45.4	-	∅2	M3x3.5	2.5	12	8	6	4.5	3.5	25	10	M3x8	3.72	5.88	38.22	36.26	36.26	0.054	0.65
MN15C	16	4	8.5	32	25	3.5	20	26.7	42.1	4.5	M3	M3x4	3	15	10	6	4.5	3.5	40	15	M3x10	4.61	5.59	45.08	21.56	21.56	0.059	1.06
MN15H	16	4	8.5	32	25	3.5	25	43.4	58.8	4.5	M3	M3x4	3	15	10	6	4.5	3.5	40	15	M3x10	6.37	9.11	73.50	57.82	57.82	0.092	1.06

Note : 1 kgf = 9.81 N

Model No.	Dimensions of Assembly (mm)			Dimensions of Block (mm)										Dimensions of Rail (mm)				Mounting Bolt for Rail (mm)	Basic Dynamic Load Rating C (kN)	Basic Static Load Rating C ₀ (kN)	Static Rated Moment			Weight					
	H	H ₁	N	W	B	B ₁	C	L ₁	L	G	G _n	MxI	H ₂	W _R	H _R	D	h				d	P	E	M _R	M _P	M _V	Block	Rail	
	mm	mm	mm	mm	mm	mm	mm	mm	mm	mm	mm	mm	mm	mm	mm	mm	mm				mm	mm	mm	mm	N-m	N-m	N-m	kg	kg/m
MW7C	9	1.9	5.5	25	19	3	10	21	31.2	-	∅1.2	M3x3	1.85	14	-	5.2	6	3.2	3.5	30	10	M3x6	1.37	2.06	15.70	7.14	7.14	0.020	0.51
MW7H	9	1.9	5.5	25	19	3	19	30.8	41	-	∅1.2	M3x3	1.85	14	-	5.2	6	3.2	3.5	30	10	M3x6	1.77	3.14	23.45	15.53	15.53	0.029	0.51
MW9C	12	2.9	6	30	21	4.5	12	27.5	39.3	-	∅1.2	M3x3	2.4	18	-	7	6	4.5	3.5	30	10	M3x8	2.75	4.12	40.12	18.96	18.96	0.040	0.91
MW9H	12	2.9	6	30	23	3.5	24	38.5	50.7	-	∅1.2	M3x3	2.4	18	-	7	6	4.5	3.5	30	10	M3x8	3.43	5.89	54.54	34.00	34.00	0.057	0.91
MW12C	14	3.4	8	40	28	6	15	31.3	46.1	-	∅1.2	M3x3.6	2.8	24	-	8.5	8	4.5	4.5	40	15	M4x8	3.92	5.59	70.34	27.80	27.80	0.071	1.49
MW12H	14	3.4	8	40	28	6	28	45.6	60.4	-	∅1.2	M3x3.6	2.8	24	-	8.5	8	4.5	4.5	40	15	M4x8	5.10	8.24	102.70	57.37	57.37	0.103	1.49
MW15C	16	3.4	9	60	45	7.5	20	38	54.8	5.2	M3	M4x4.2	3.2	42	23	9.5	8	4.5	4.5	40	15	M4x10	6.77	9.22	199.34	56.66	56.66	0.143	2.86
MW15H	16	3.4	9	60	45	7.5	35	57	73.8	5.2	M3	M4x4.2	3.2	42	23	9.5	8	4.5	4.5	40	15	M4x10	8.93	13.38	299.01	122.60	122.60	0.215	2.86

Note : 1 kgf = 9.81 N

ABOUT LIMON BALL SCREW

Ball screw are ideal for converting rotary motion into linear motion or converting linear motion into rotary motion. Ball screw is the most commonly used transmission component in tool machinery and precision machinery. Its main function is to convert rotary motion into linear motion or to convert torque into axial repetitive force, which is high precision, reversibility and high efficiency. Due to the small frictional resistance, ball screw are widely used in a variety of industrial equipment and precision instruments. The ball screw is composed of screw, nut, steel balls, preloading piece, deflector and dust-proof end seals.

1. General Information

1-1 Features of LIMON Ball Screw

(1) High Reliability

LIMON applies stringent quality control standards on every production process. With proper lubrication and use, trouble-free operation for an extended period of time is possible.

(2) Smooth Operation

The high efficiency of ball screw is vastly superior than conventional screws as shown in Fig 3.1.1. It takes less than 30% torque to make the linear motion into rotary motion.

(3) High Rigidity and Preload

The ball screw of LIMON is designed with Gothic arch groove, which makes the screw easy to rotate even using minimum axial play. To make the rigidity more appropriate to using condition, you can change the preload between one or two screw nuts to reduce axial play.



Fig 3.1.1 Groove Shape of LIMON Precision Ball Screw

(4) Circulation Method

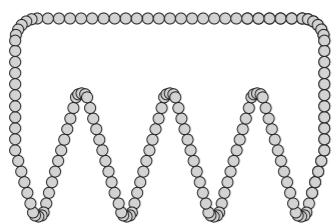

Fig 3.1.2 External Ball Circulation Nuts

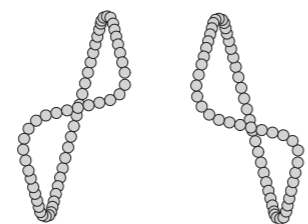
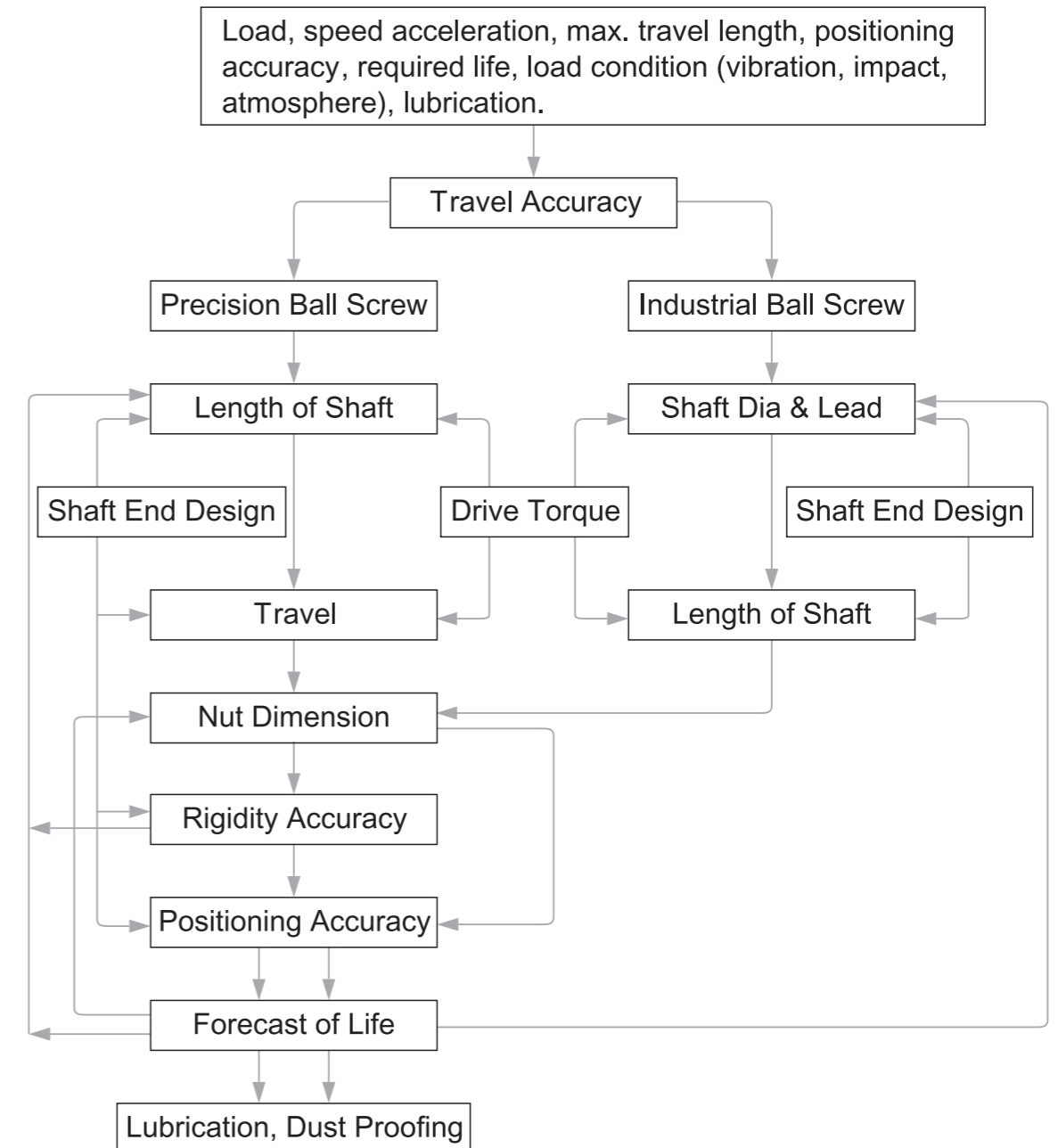

Fig 3.1.3 Internal Ball Circulation Nuts

(5) High Durability

1-2 Ball Screw Selection Procedure



1-3 Selection of Nut

- (1) Series
When making selection of series, please take demanded accuracy, intended delivery time, dimensions (the outside diameter of screw, ratio of lead / the outside diameter of screw) preload and etc into consideration.
- (2) Circulation type
Selection of circulation type, please consider the efficiency of screw nut's mounting space. The advantage of each circulation type will be specified in figure 3.4.1.
- (3) Number of loop circuits
Performance and service life should be considered when selecting number of loop circuits.
- (4) Shape of flanges
Please make selection based on the available space for the installation of nuts.
- (5) Oil hole
Oil holes are provided for the precision ball screws, please use them during machine assembling and regular furnishing.

1-4 Nut Design

1-4-1 Circulation type

Circulation type	Model		Characteristic
	Single Nut	Double Nuts	
Internal circulation type	SFK SFU SFI SFNU SFNI	DFU DFI DFNU DFNI	<ul style="list-style-type: none"> • Delicated diameter of screw takes only little space. • Applicable to those with smaller lead / the outside diameter of the screw
External circulation type	SFV XSV BSH	DFV	<ul style="list-style-type: none"> • Economy • Applicable to larger lead and diameter. • Applicable for high loading purpose.
End-caps circulation type	SFS SFY SFA	DFS	<ul style="list-style-type: none"> • Suitable for high speed positioning

1-4-2 Nut Types

U, I, NU, NI-Type Nut

In these types of nuts, by using the internal circulator which makes the ball pass over the crest diagonally, the ball will return to the starting point. Normally, one roll of balls will fit with one circulation. As figure 3.4.1 specified, these types of nuts need at least one side which is completely tooth passing, which is applicable for smaller shaft diameter.

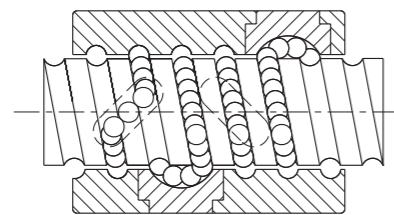

Fig 3.4.1 U, I - Type Nut

K - Type Nut

It applies the similar circulation as that of I-type, but circulation takes place in key slots of identical angle for different circulation. (see Fig 3.4.2)

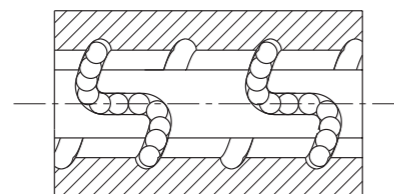

Fig 3.4.2 K - Type Nut

V - Type Nut

Using outer circulation, the special design of circulator allows the balls to roll along the thread direction. By so, the smoothness of circulation is increased and meanwhile decrease the mutual collision. It's a suitable type for high speed and heavy loading.

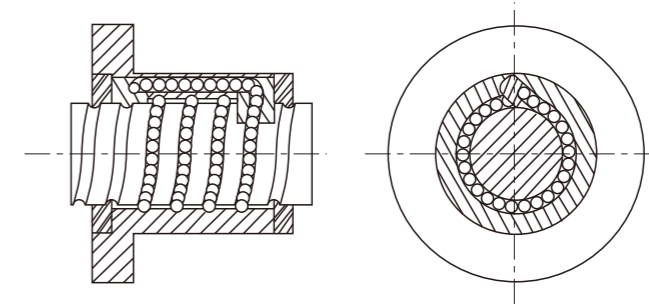

Fig 3.4.3 V - Type Nut

S, Y, E, H-Type Nut

By using thin and flexible dust cap on both side, the performance of wiping had been enhanced. Moreover, the enhancement of circulation structure increase both the function of high rigidity and speed.

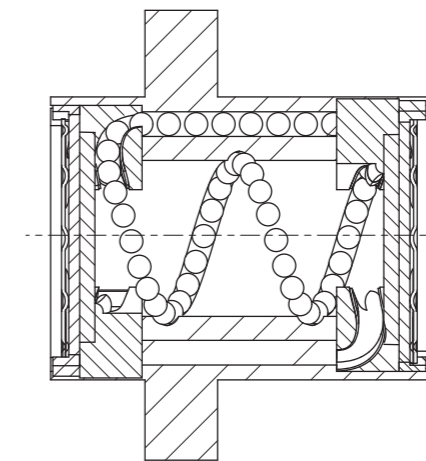

Fig 3.4.4 S, Y, E, H - type nut

1-5 Accuracy

1-5-1 Lead/Travel Accuracy

Mean Travel Deviation ($\pm E$) and Travel Variation (e) (JIS B 1192)
Variation per 300mm (e_{300}) and Wobble Error ($e_{2\pi}$) (JIS B 1192)

Table 1-5-1 Unit : μm

Grade		C0	C1	C2	C3	C5	C7	C10						
e_{300}		3.5	5	7	8	18	50	210						
$e_{2\pi}$		2.5	4	5	6	8								
Travel Length (mm)	Over	Incl.	$\pm E$	e	$\pm E$	e	$\pm E$	e	$\pm E$	e	$\pm E$	e	e	e
		100	3	3	3.5	5	5	7	8	8	18	18	$\pm 50/300\text{mm}$	$\pm 210/300\text{mm}$
		100	200	3.5	3	4.5	5	7	7	10	8	20		
		200	315	4	3.5	6	5	8	7	12	8	23		
		315	400	5	3.5	7	5	9	7	13	10	25		
		400	500	6	4	8	5	10	7	15	10	27		
		500	630	6	4	9	6	11	8	16	12	30		
		630	800	7	5	10	7	13	9	18	13	35		
		800	1000	8	6	11	8	15	10	21	15	40		
		1000	1250	9	6	13	9	18	11	24	16	46		
		1250	1600	11	7	15	10	21	13	29	18	54		
		1600	2000			18	11	25	15	35	21	65		
		2000	2500			22	13	30	18	41	24	77		
	2500	3150			26	15	36	21	50	29	93			
	3150	4000			30	18	44	25	60	35	115			
	4000	5000					52	30	72	41	140			
	5000	6300					65	36	90	50	170			
	6300	8000							110	60	210			
	8000	10000									260			
	10000	12500									320			

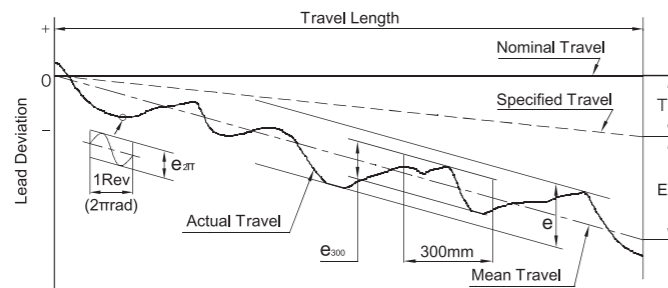

Fig 1.5.1 Diagram of Lead Accuracy

1-5-2 Axial Play

Axial play of LIMON precision ball screw is shown as follows

Table 1-5-2 Classification of Axial Play

Grade	P0	P1	P2	P3	P4
Axial Play	Yes	No	No	No	No
Preload	No	No	Light	Medium	Heavy

Excessive preload increases the friction torque and generates heat which will reduce the life expectancy. However, insufficient preload will reduce stiffness and increase the possibility of lost motion. LIMON recommends that the preload applied on CNC machine tools should not heavier than 8% of the dynamic load; 5% for industrial automation X-Y table.

Table 1.5.3 The reference spring force of (P2)

Model No.	Spring Force (Kg) Single Nut	Spring Force(Kg) Double Nut
1605	0.1~0.3	0.3~0.6
2005	0.1~0.3	0.3~0.6
2505	0.2~0.5	0.3~0.6
3205	0.2~0.5	0.5~0.8
4005	0.2~0.5	0.5~0.8
2510	0.2~0.5	0.5~0.8
3210	0.3~0.6	0.5~0.8
4010	0.3~0.6	0.5~0.8
5010	0.3~0.6	0.8~1.2
6310	0.6~1.0	0.8~1.2
8010	0.6~1.0	0.8~1.2

Table 1.5.4 Axial Play (P0) Clearance in the Axial Direction of Rolled and Ground Ball Screw Unit : mm

Nominal Diameter	Rolled Ball Screw Clearance in the Axial Direction (max.)	Ground Ball Screw Clearance in the Axial Direction (max.)
$\varnothing 04\sim\varnothing 14$ miniature ball screw	0.05	0.015
$\varnothing 15\sim\varnothing 40$ middle size of ball screw	0.08	0.025
$\varnothing 50\sim\varnothing 100$ big size of ball screw	0.12	0.05

1-5-3 Definition of Mounting Accuracy and Tolerance on Ball Screw

The main items of the mounting accuracy of ball screw are listed in below.

- (1) Periphery run-out of the supporting part of the screw shaft to the screw groove.
- (2) Concentricity of a mounting portion of the shaft to the adjacent ground portion of the screw shaft.
- (3) Perpendicularity of the shoulders to the adjacent ground portion of the screw shaft.
- (4) Perpendicularity of the nut flange to the axis of the screw shaft.
- (5) Concentricity of the ball nut diameter to the screw groove.
- (6) Parallelism of the mounting surface of a ball nut to the screw groove.
- (7) Total run-out of the screw shaft to the axis of the screw shaft.

1-6 Screw Shaft Design

1-6-1 Mounting Methods

It's important to consider mounting method (Fig 3.6.1~3.6.8) during your selection of ball screw specification. If you have special requirement related with mounting method, please consult LIMON.

(Mounting Screw and Nut)

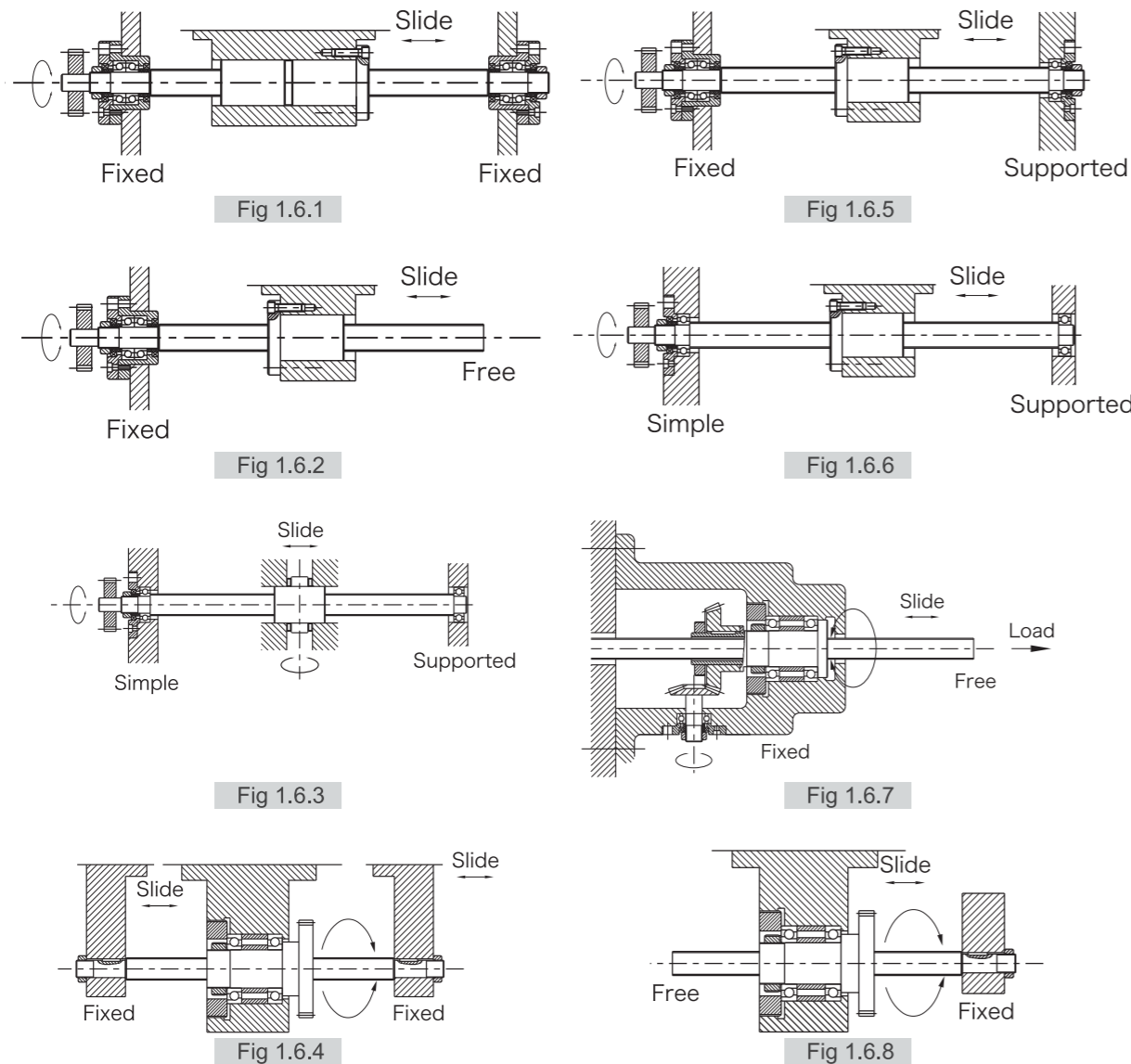

(The mounting method for common types of machinery.)

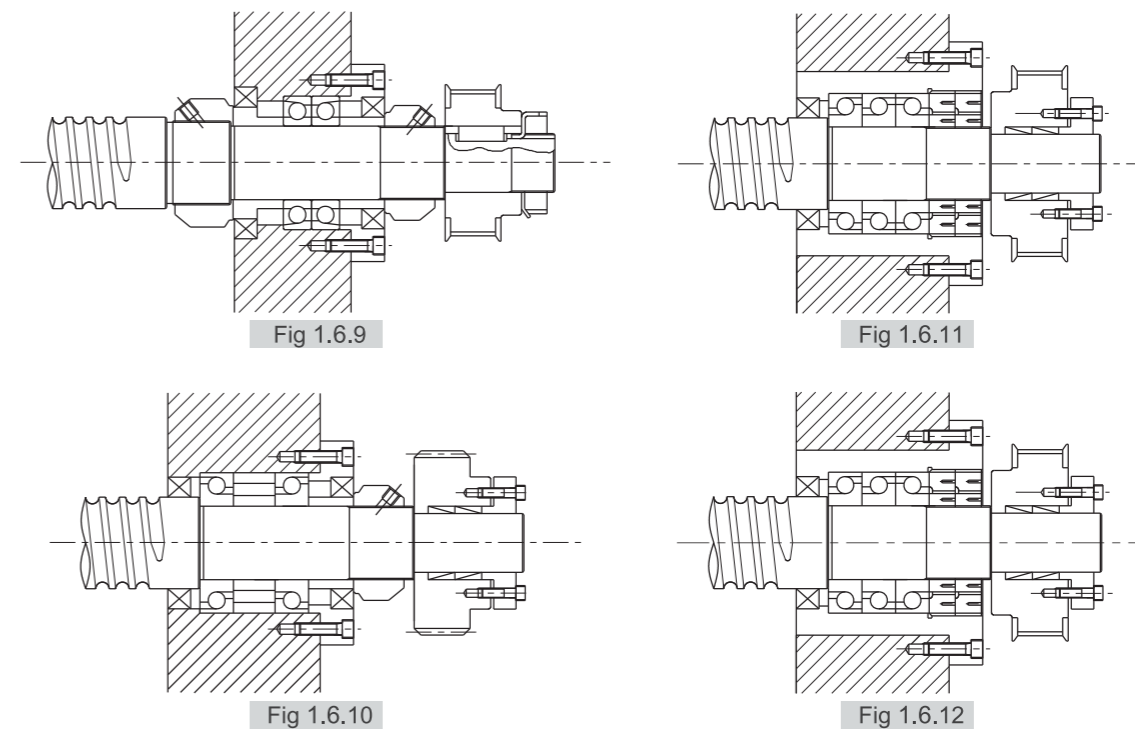

(The mounting method for bearing in a given pretension.)

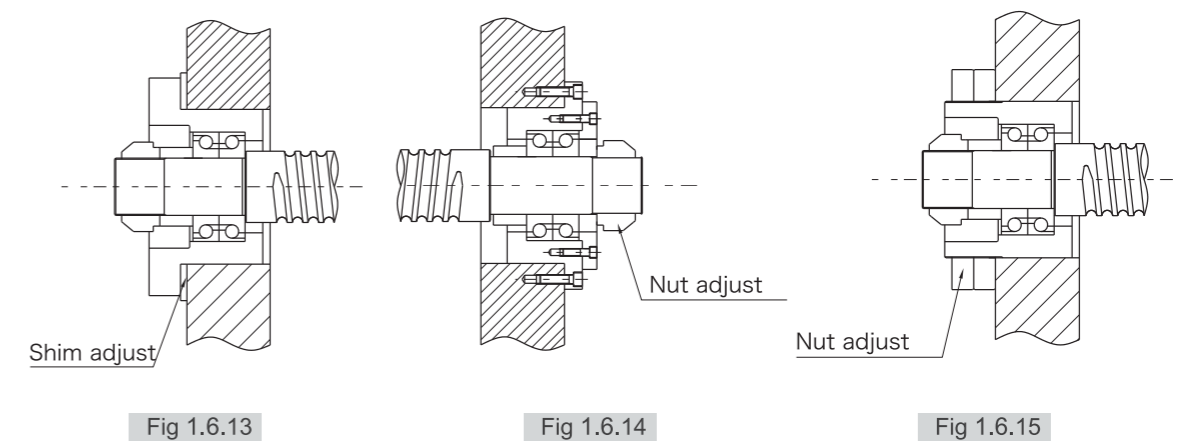

1-7 Positioning Accuracy

Among the factors that cause feed accuracy errors, lead accuracy and feed system rigidity are the key points for review, while other factors such as heat deformation due to temperature rise as well as assembly accuracy for the guiding surface, etc. should also be considered.

1-7-1 Accuracy Selection

Table 1.7.1 shows the recommended application ranges for various ball screws accuracy classes based on different.

Table 1-7-1 Examples of ball screws accuracy classes for different uses

Application		Accuracy Grade							
		C0	C1	C2	C3	C5	C7	C10	
NC Machine Tools	Lathe	X	○	○	○	○	○	○	
		Y				○	○	○	
	Milling Machine Boring Machine	XY		○	○	○	○	○	
		Z			○	○	○	○	
	Machine Center	XY		○	○	○	○		
		Z			○	○	○		
	Jig Borer	Y	○	○					
		Z	○	○					
	Drilling Machine	XY				○	○	○	
		Z						○	○
	Grinding Machine	X	○	○	○	○	○	○	
		Z		○	○	○	○	○	
	Electro-discharge Machine (EDM)	XY		○	○	○	○	○	
		(Z)			○	○	○	○	
Wire Cut (EDM)	Y		○	○	○				
	UV		○	○	○	○	○		
Punching Press	XY				○	○	○		
Laser Cutting Machine	XY				○	○			
	Z				○	○			
Wood Working Machine				○	○	○	○		
Machines of General use and special Use				○	○	○	○		
Semiconductor Machines	Explosure Equipments	○	○						
	Chemical Treatment				○	○	○	○	
	Wire Bonder		○	○	○				
	Prober	○	○	○	○				
	Inserter			○	○	○	○		
	PCB Driller		○	○	○	○	○		
Industrial Robots	Orthogonal Type	As'sy		○	○	○	○	○	
		Others					○	○	○
	Multi-joints Type	As'sy			○	○	○		
		Others				○	○	○	
SCARA Type			○	○	○	○			
Machines for Steel molding						○	○	○	
Injection Molding Machines						○	○	○	
Three-Dimensional Measuring Machines	○	○	○						
Business Machines						○	○	○	
Pattern Image Machines	○	○							
Nuclear	Rod Control				○	○	○		
	Mechnaical Snubber						○	○	
	Aircrafts				○	○			

1-8 Cautions About Use of Ball Screws

Ball screw assemblies are delicate components. Therefore, extra care must be taken to prevent the ball track from damages that caused by edged component or tools. Meanwhile, to prevent steel ball fall out of the nut through the disassembly of screw and nut or over stroke, please be careful while operating. If the steel ball falls out, please contact with LIMON for further instruction. Do not attempt to reassemble, which might cause permanent damage to the ball screw.)

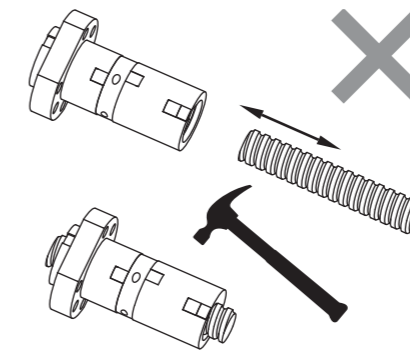

Fig 3.8.1 Error installation

If disassemble is required, please use a transfer pipe which has minor diameter than the screw diameter to transfer the nut to prevent falling out of the steel balls.

1-9 Lubrication

Adequate lubrication must be provided when ball screw is used, insufficient lubrication will result in collision of metal, which leads to increase of friction and detrition, thus cause failure or shortening the service life.

Lubricants applied to ball screws can be divided into 2 types, namely lubricating oil and consistent grease. In general speaking, in respect of maintenance, consistent grease will lead to increase of dynamic friction torque linearly along with increase of rotating speed, hence oil lubrication is deemed the better way when speed exceeds 3-5 m/min; however, don't forget the fact that there have been examples that using grease has been capable of achieving speed of 10 m/min, with respect to the equipment.

In terms of equipments, there are some cheaper lubricant that can be used. In general, to fully utilize the function of ball screw, lubricating oil of 5m/minute is the best option to choose. In figure 3.9.1, we provide the standard of lubricating oil inspection and supplement interval. Before replenishing, please clean up the previous grease to continue.

Table 1-9-1 Inspection of lubrication and interval of reill

Method	Interval	Check Item	Replenish or Change Interval
Auto. Periodial oil supply	Weekly	Oil level, contamination	Add at each check, as required depending on tank level
Grease	Initially 2~3 months	Contamination on entry of chip	replenish yearly or according to the inspection result.
Oil bath	Daily	Oil level	To be determined according to consumption

1-10 Dust Proof / Prevention

Any foreign matter or water, if entering to the ball screw, may increase friction and cause damage. For example, the entry of chips or cutting oil may be expected with machine tools according to the work environment. Where entry of foreign matter is anticipated, use a bellows or telescopic cover as shown in Fig 1.10.1, to cover the screw shaft completely.

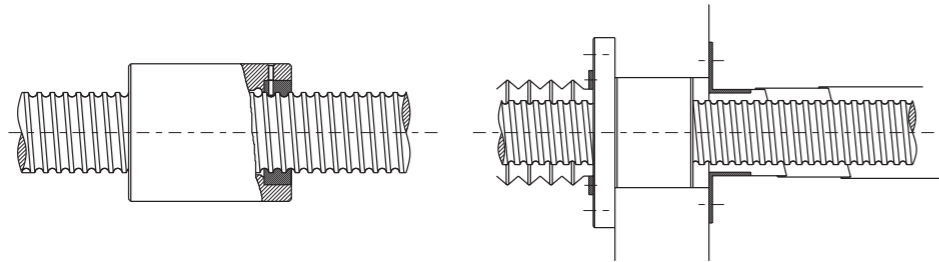

Fig 1.10.1 Dust proof Method by Telescopic Cover and Bellows

1-11 Offset Load

When offset load phenomenon occurs, screw life and noise tend to be directly affected, which would usually be accompanied with hand feel of rough running. As the smoothness of single shaft and assembled ball screw might be different. In addition to single shaft's accuracy, the offset phenomenon was mostly occurred by failed assemble accuracy which is shown in Fig 1.11.1

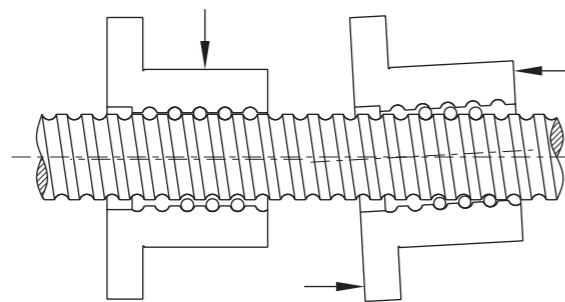
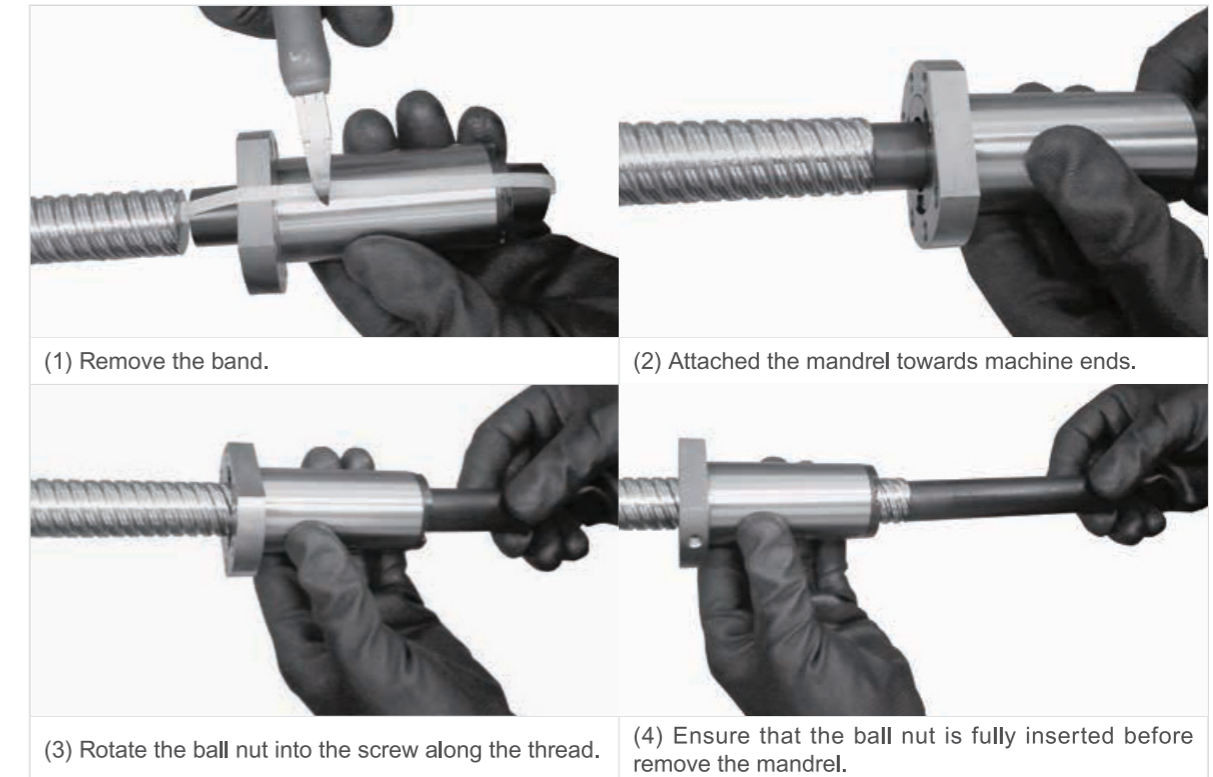

Fig 1.11.1 Offset Load

1-12 Assembling the Ball Screws

If rolled ball nut is shipped un-assembled please follow the procedure as below.

Table 1-12-1 Procedure



1-13 Nominal Model Code of Limon Ball Screw

SFU R 025 05 T4 D G C5 - 600 - P1 - B2 + N3 N3

① ② ③ ④ ⑤ ⑥ ⑦ ⑧ ⑨ ⑩ ⑪ ⑫ ⑬

① Nominal Model	② Threading Direction	⑤ Number of Turns (Turn-Row)	⑦ Product Code
S : Single nut D : Double nut	R : Right L : Left	Turn : T : 1 A : 1.5 (or 1.7/1.8) B : 2.5/2.8	G : Ground F : Rolled
F : With flange C : Without flange	③ Nominal Diameter	C : 3.5 D : 4.8	⑧ Accuracy Grade
NI : type nut NU : type nut H : type nut	Unit : mm	ex : (2.5×2 = B2)	C0, C1, C2, C3, C5, C7, C10
U S : type nut E : type nut Y : type nut V : type nut K : type nut DC : type nut	④ Lead Unit : mm	⑥ Flange Type N : Not cutting S : Single cutting D : Double cutting	⑨ Overall Length of Shaft Unit : mm

⑩ Axial Clearance and Preload Value	⑪ Number of Nut
P0, P1, P2, P3, P4	(Leave blank if only one nut is required) Ex : Install two nuts on a shaft B2

⑫ Nut Surface Treatment	⑬ Shaft Surface Treatment
S : Standard	S : Standard
B1 : Black Oxidation	B1 : Black Oxidation
N1 : Hard Chrome Plating	N1 : Hard Chrome Plating
P : Phosphating	P : Phosphating
N3 : Nickel Plating	N3 : Nickel Plating
N4 : Raydent	N4 : Raydent
N5 : Chrome Plating	N5 : Chrome Plating

※ No symbol required when plating is not needed.
 ※ An inspection report is provided for ground ball screws with an accuracy higher than C5.

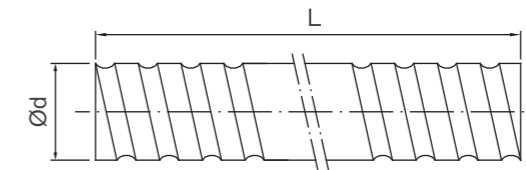
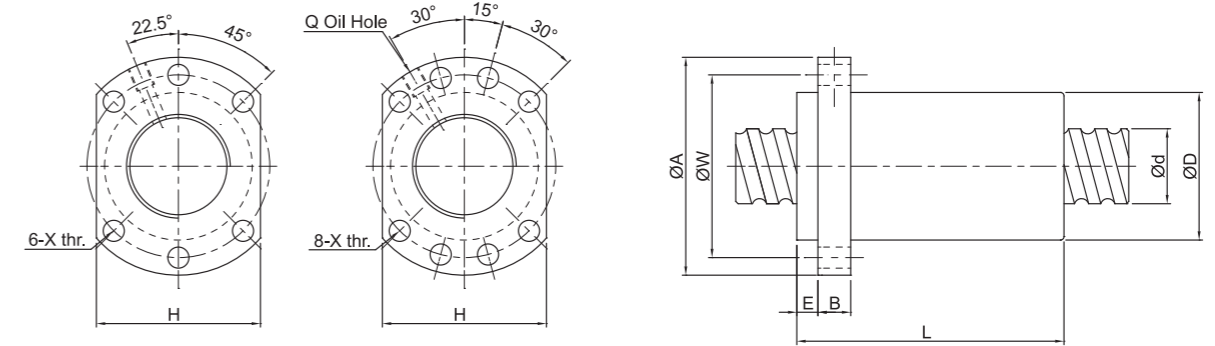

Fig 1.13.1 Screw Shaft Nominal Diameter

Table 1-13-1 Ground Ball Screw Specifications Ø4~32

Ød	Model No.		Accuracy Grade	Threading Direction R : Right L : Left	Number of Grooves	Standard Code of	Type of Nut	
	I	Da						
6	1	0.8	C7	R	1	SCR00601	K	1000
	1	0.8	C7, C5	R	1	SCR00801	K	
8	2	1.2	C7, C5	R	1	SCR00802	K	1000
	2.5	1.2	C7, C5	R	1	SCR0082.5	K, BSH	
10	2	1.2	C7, C5	R	1	SCR01002	K, BSH	3000
	4	2	C7, C5	R	1	SCR01004	K, BSH	
12	2	1.2	C7, C5	R	1	SCR01202	K	3000
	4	2.5	C7, C5	R	1	SCR01204	U, BSH	
	5	2.5	C7, C5	R	1	SCR01205-A	V, U, BSH, S, H	
	5	2.5	C7, C5	R	1	SCR01205-B	K	
	10	2.5	C7, C5	R	2	SCR01210-B	V	
14	2	1.2	C7, C5	R	1	SCR01402	K	1800
	4	2.5	C7	R	1	SCR01404	BSH	
16	4	2.381	C7, C5	R	1	SCR01604(N)	V, I, U, BSH	3000
	5	3.175	C7, C5	R/L	1	SCR01605	V, I, U, BSH	
	10	3.175	C7, C5	R	2	SCR01610	V, I, U, BSH	
	16	2.778	C7, C5	R	4	SCR01616	Y	
	32	2.778	C7	R	8	SCR01632	Y	
20	4	2.381	C7, C5	R	1	SCR02004(N)	V, I, U	3000
	5	3.175	C7, C5	R/L	1	SCR02005	V, U, BSH, S, H	
	20	3.175	C7, C5	R	4	SCR02020	V, Y, S, H	
	40	3.175	C7	R	8	SCR02040	Y	
25	4	2.381	C7	R	1	CR02504(N)	I, U	6000
	5	3.175	C7, C5	R/L	1	SCR02505	V, U, BSH, S, H	
	10	4.762	C7, C5	R	1	SCR02510-A	I, U, BSH	
	10	6.35	C7, C5	R	1	SCR02510-B	V	
	25	3.969	C7, C5	R	4	SCR02525	V, Y	
32	50	3.969	C7	R	8	SCR02550	Y	
	4	2.381	C7, C5	R	1	SCR03204(N)	V, I, U	6000
	5	3.175	C7, C5	R/L	1	SCR03205	V, I, U, M, S, H	
	10	6.35	C7, C5	R/L	1	SCR03210	V, I, U	
	32	4.762	C7	R	4	SCR03232	Y	
64	4.762	C7	R	8	SCR03264	Y		

2 Ball Screw Classification 2-1 Size Table of SFA Ball Screws



$d \leq 32$

$d \geq 40$

I:Lead Da:Ball Diameter n:Number of Circuits K:Stiffness(Kgf/μm)
Ca:Basic Dynamic Rating Load(Kgf) Coa: Basic Static Rating Load(Kgf)

Table 1-13-2 Standard Specifications Ø40~80

Unit : mm

Model No.			Accuracy Grade	Threading Direction R : Right L : Left	Number of Grooves	Standard Code of Shaft	Type of Nut	Rolled Ball Screw maximum length
d	l	Da						
40	5	3.175	C7, C5	R/L	1	SCR04005	V, I, U, S, H	6000
	10	6.35	C7	R/L	1	SCR04010	V, I, U	
	20	6.35	C7	R	2	SCR04020	V	
	40	6.35	C7	R	4	SCR04040	Y	
	80	6.35	C7	R	8	SCR04080	Y	
50	5	3.175	C7, C5	R	1	SCR05005	V, S, H	6000
	10	6.35	C7, C5	R/L	1	SCR05010	V, I, U	
	20	9.525	C7	R	1	SCR05020	V	
	50	7.938	C7	R	4	SCR05050	Y	
	100	7.938	C7	R	8	SCR050100	Y	
63	10	6.35	C7, C5	R	1	SCR06310	V, I, U	7000
	20	9.525	C7	R	1	SCR06320	V, U	
80	10	6.35	C7, C5	R	1	SCR08010	V, I, U	7000
	20	9.525	C7	R	1	SCR08020	V, U	

Table 1-13-3 H-type Specifications Ø16~50

Unit : mm

Model No.			Accuracy Grade	Threading Direction R : Right L : Left	Number of Grooves	Type-H Code of Shaft	Type of Nut	Rolled Ball Screw maximum length
Ød	l	Da						
12	10	2.5	C7, C5	R	2	SSR01210	S	3000
16	5	2.778	C7, C5	R	1	SSR01605	S, H	3000
	10	2.778	C7, C5	R	2	SSR01610	S, H	
	16	2.778	C7, C5	R	4	SSR01616	S, H	
	20	2.778	C7, C5	R	4	SSR01620	S	
20	10	3.175	C7, C5	R	2	SSR02010	S, H	3000
25	10	3.175	C7, C5	R	2	SSR02510	S, H	6000
	25	3.175	C7	R	4	SSR02525	S, H	
32	10	3.969	C7, C5	R	1	SSR03210	S, H	6000
	20	3.969	C7	R	2	SSR03220	S, H	
	32	3.969	C7	R	4	SSR03232	S	
40	10	6.35	C7	R	1	SSR04010	S, H	6000
	20	6.35	C7, C5	R	2	SSR04020	S	
	40	6.35	C7	R	4	SSR04040	S	
50	10	6.35	C7	R	1	SSR05010	S, H	6000
	20	6.35	C7	R	2	SSR05020	S	
	50	6.35	C7	R	4	SSR05050	S	

* The information is for specifications, if customized products are needed please contact LIMON.

Unit : mm

Model no.	d	l	Da	Dimension										Load Rating		K
				D	A	E	B	L	W	H	X	Q	n	Ca(kgf)	Ca(kgf)	
SFA0802-3.8	8	2	1.2	14	27	3	5	17.5	21	18	4-Φ3.4	/	3.8*1	208	419	13
SFA0802.5-3.8		2.5	1.2	14	27	3	5	20	21	18	4-Φ3.4	/	3.8*1	207	418	13
SFA0805-1.8	10	5	1.2	14	27	3	5	19	21	18	4-Φ3.4	/	1.8*1	107	195	6
SFA1004-3.8		4	2	26	46	4	10	30	36	28	4-Φ4.5	M6*1	3.8*1	439	827	16
SFA1006-2.8	12	6	1.588	18	35	5	6	26	27	22	4-Φ4.5	/	2.8*1	247	482	11
SFA1012-1.8		12	1.588	18	35	5	6	32	27	22	4-Φ4.5	/	1.8*1	164	311	7
SFA1205-2.8	12	5	2.5	24	40	5	10	30	32	30	6-Φ4.5	M6*1	2.8*1	487	886	14
SFA1210-2.8		10	2.5	24	40	5	10	42	32	30	6-Φ4.5	M6*1	2.8*1	472	865	13
SFA1220-1.8	14.8	20	2.5	24	40	5	10	50	32	30	6-Φ4.5	M6*1	1.8*1	313	578	8
SFA1605-3.8		5	2.778	28	48	5	10	31	38	40	6-Φ5.5	M6*1	3.8*1	821	1706	22
SFA1610-2.8	14.8	10	2.778	28	48	5	10	42	38	40	6-Φ5.5	M6*1	2.8*1	643	1311	17
SFA1616-1.8		16	2.778	28	48	5	10	43	38	40	6-Φ5.5	M6*1	1.8*1	423	818	11
SFA1616-2.8	14.8	16	2.778	28	48	5	10	59	38	40	6-Φ5.5	M6*1	2.8*1	618	1272	16
SFA1620-1.8		20	2.778	28	48	5	10	50	38	40	6-Φ5.5	M6*1	1.8*1	424	841	11
SFA2005-3.8	20	5	3.175	36	58	7	10	33	47	44	6-Φ6.6	M6*1	3.8*1	1135	2655	29
SFA2010-3.8		10	3.175	36	58	7	10	52	47	44	6-Φ6.6	M6*1	3.8*1	1160	2765	29
SFA2020-1.8	20	20	3.175	36	58	7	10	52	47	44	6-Φ6.6	M6*1	1.8*1	585	1268	14
SFA2020-2.8		20	3.175	36	58	7	10	72	47	44	6-Φ6.6	M6*1	2.8*1	855	1972	21
SFA2505-3.8	25	5	3.175	40	62	7	10	33	51	48	6-Φ6.6	M6*1	3.8*1	1239	3219	33
SFA2510-3.8		10	3.175	40	62	7	12	52	51	48	6-Φ6.6	M6*1	3.8*1	1263	3333	35
SFA2520-2.8	25	20	3.175	40	62	7	12	76	51	48	6-Φ6.6	M6*1	2.8*2	943	2400	25
SFA2525-1.8		25	3.175	40	62	7	12	60	51	48	6-Φ6.6	M6*1	1.8*1	647	1578	16
SFA2525-2.8	32	25	3.175	40	62	7	12	85	51	48	6-Φ6.6	M6*1	2.8*1	947	2454	25
SFA3205-3.8		5	3.175	50	80	9	12	35	65	62	6-Φ9	M6*1	3.8*1	1407	4347	41
SFA3210-3.8	31	10	3.969	50	80	9	13	53	65	62	6-Φ9	M6*1	3.8*1	1883	5234	42
SFA3220-2.8		20	3.969	50	80	9	12	72	65	62	6-Φ9	M6*1	2.8*1	1459	3954	32
SFA3232-1.8	31	32	3.969	50	80	9	13	78	65	62	6-Φ9	M6*1	1.8*1	962	2471	20
SFA3232-2.8		32	3.969	50	80	9	13	110	65	62	6-Φ9	M6*1	2.8*1	1406	3844	31
SFA4005-3.8	40	5	3.175	63	93	9	15	39	78	70	8-Φ9	M8*1	3.8*1	1544	5474	49
SFA4010-3.8		10	6.35	63	93	9	14	57	78	70	8-Φ9	M8*1	3.8*1	3863	10046	53
SFA4020-2.8	38	20	6.35	63	93	9	14	78	78	70	8-Φ9	M8*1	2.8*1	3815	9950	52
SFA4040-1.8		40	6.35	63	93	9	15	96	78	70	8-Φ9	M8*1	1.8*1	1980	4783	25
SFA4040-2.8	50	40	6.35	63	93	9	15	136	78	70	8-Φ9	M8*1	2.8*1	2895	7441	38
SFA5005-3.8		5	3.175	75	110	10.5	15	42	93	85	8-Φ11	M8*1	3.8*1	1689	6883	58
SFA5010-3.8	48	10	6.35	75	110	10.5	18	57	93	85	8-Φ11	M8*1	3.8*1	4314	12877	63
SFA5020-3.8		20	6.35	75	110	10.5	18	98	93	85	8-Φ11	M8*1	3.8*1	4399	13333	66
SFA5050-1.8	50	50	6.35	75	110	10.5	18	117	93	85	8-Φ11	M8*1	1.8*1	2254	6311	31
SFA5050-2.8		50	6.35	75	110	10.5	18	167	93	85	8-Φ11	M8*1	2.8*1	3296	9817	47

2-2 Size Table of SFS Ball Screws

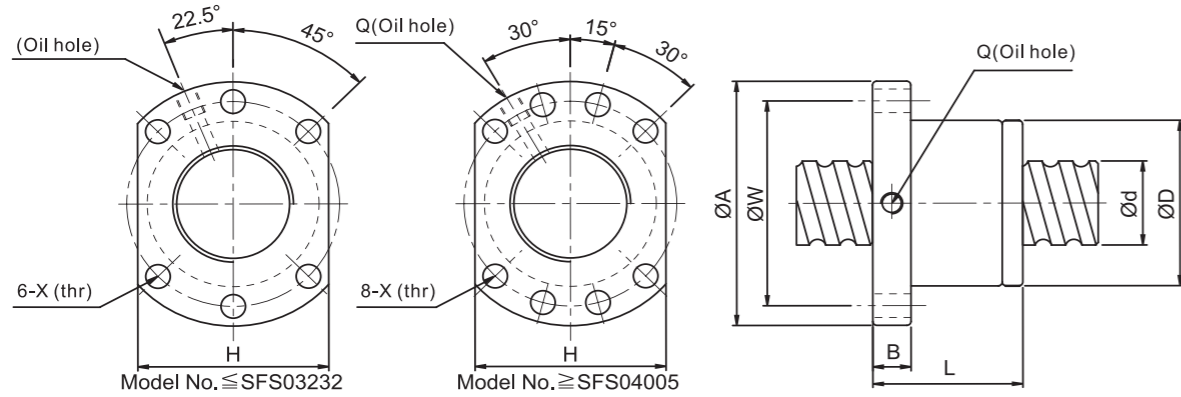

l:Lead Da:Ball Diameter n:Number of Circuits K:Stiffness(Kgf/μm)
 Ca:Basic Dynamic Rating Load(Kgf) Coa: Basic Static Rating Load(Kgf)

Unit:mm

Model no.	d	l	Da	Dimension									Load Rating Ca(kgf)	Load Rating Coa(kgf)	K kgf/μm
				D	A	B	L	W	H	X	Q	n			
SFS1205-2.8	12	5	2.5	24	40	10	31	32	30	6-Φ4.5		2.8*1	487	886	14
SFS1210-2.8		10	2.5	24	40	10	48.5	32	30	6-Φ4.5		2.8*1	472	865	13
SFS1605-3.8	14.8	5	2.778	28	48	10	37.5	38	40	6-Φ5.5	M6*1	3.8*1	821	1706	22
SFS1610-2.8		10	2.778	28	48	10	47	38	40	6-Φ5.5	M6*1	2.8*1	643	1311	17
SFS1616-1.8		16	2.778	28	48	10	45	38	40	6-Φ5.5	M6*1	1.8*1	423	818	11
SFS1620-1.8		20	2.778	28	48	10	56	38	40	6-Φ5.5	M6*1	1.8*1	424	841	11
SFS2005-3.8	20	5	3.175	36	58	10	40	47	44	6-Φ6.6	M6*1	3.8*1	1135	2655	29
SFS2010-3.8		10	3.175	36	58	10	60	47	44	6-Φ6.6	M6*1	3.8*1	1160	2765	299
SFS2020-1.8		20	3.175	36	58	10	57	47	44	6-Φ6.6	M6*1	1.8*1	585	1268	14
SFS2505-3.8	25	5	3.175	40	62	10	40	51	48	6-Φ6.6	M6*1	3.8*1	1239	3219	33
SFS2510-3.8		10	3.175	40	62	12	62	51	48	6-Φ6.6	M6*1	3.8*1	1263	3333	35
SFS2525-1.8		25	3.175	40	62	12	70	51	48	6-Φ6.6	M6*1	1.8*1	647	1578	16
SFS2525-2.8			3.175	40	62	12	95	51	48	6-Φ6.6	M6*1	2.8*1	947	2454	25
SFS3205-3.8	32	5	3.175	50	80	12	42	65	62	6-Φ9	M6*1	3.8*1	1407	4347	41
SFS3210-3.8	31	10	3.969	50	80	13	62	65	62	6-Φ9	M6*1	3.8*1	1883	5234	42
SFS3220-2.8		20	3.969	50	80	12	80	65	62	6-Φ9	M6*1	2.8*1	1459	3954	32
SFS3232-1.8		32	3.969	50	80	13	84	65	62	6-Φ9	M6*1	1.8*1	962	2471	20
SFS3232-2.8			3.969	50	80	13	116	65	62	6-Φ9	M6*1	2.8*1	1406	3844	31
SFS4005-3.8	40	5	3.175	63	93	15	45	78	70	8-Φ9	M8*1	3.8*1	1544	5474	49
SFS4010-3.8	38	10	6.35	63	93	14	63	78	70	8-Φ9	M8*1	3.8*1	3863	10046	53
SFS4020-2.8		20	6.35	63	93	14	82	78	70	8-Φ9	M8*1	2.8*1	3815	9950	52
SFS4040-1.8		40	6.35	63	93	15	105	78	70	8-Φ9	M8*1	1.8*1	1980	4783	25
SFS4040-2.8			6.35	63	93	15	145	78	70	8-Φ9	M8*1	2.8*1	2895	7441	38
SFS5005-3.8	50	5	3.175	75	110	15	45	93	85	8-Φ11	M8*1	3.8*1	1689	6883	58
SFS5010-3.8	48	10	6.35	75	110	18	68	93	85	8-Φ11	M8*1	3.8*1	4314	12877	63
SFS5020-3.8		20	6.35	75	110	18	108	93	85	8-Φ11	M8*1	3.8*1	4399	13333	66
SFS5050-1.8		50	6.35	75	110	18	125	93	85	8-Φ11	M8*1	1.8*1	2254	6311	31
SFS5050-2.8			6.35	75	110	18	175	93	85	8-Φ11	M8*1	2.8*1	3296	9817	47

2-3 Size Table of SFNU Ball Screws

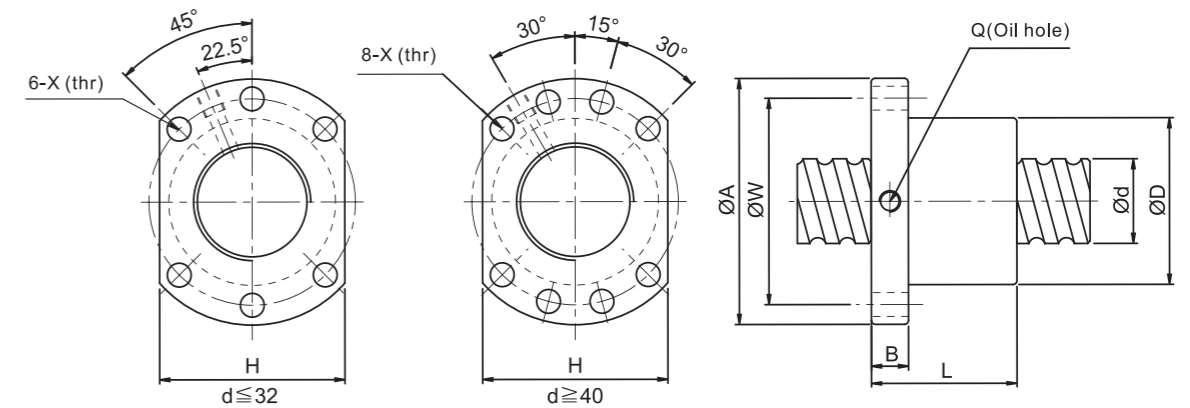

l:Lead Da:Ball Diameter n:Number of Circuits K:Stiffness(Kgf/μm)
 Ca:Basic Dynamic Rating Load(Kgf) Coa: Basic Static Rating Load(Kgf)

Unit:mm

ModelNo.	d	l	Da	Dimension									Load Rating Ca(kgf)	Load Rating Coa(kgf)	K kgf/μm
				D	A	B	L	W	H	X	Q	n			
SFNU1204-4	12	4	2.5	24	40	10	40	32	30	4.5	M6*1	4	572	1015	16
SFNU1604-4	16	4	2.381	28	48	10	40	38	40	5.5	M6*1	4	655	1417	21
SFNU1605-4		3.175	28	48	10	45	38	40	5.5	M6*1	4	919	1789	21	
SFNU1610-3	10	3.175	28	48	10	57	38	40	5.5	M6*1	3	669	1223	14	
SFU2004-3	20	4	2.381	36	58	10	42	47	44	6.6	M6*1	3	589	1436	20
SFNU2005-3		5	3.175	36	58	10	42	47	44	6.6	M6*1	3	831	1782	20
SFNU2005-4		3.175	36	58	10	51	47	44	6.6	M6*1	4	1065	2376	26	
SFU2504-4	25	4	2.381	40	62	10	42	51	48	6.6	M6*1	4	891	2447	25
SFNU2505-3		5	3.175	40	62	10	42	51	48	6.6	M6*1	3	953	2334	25
SFNU2505-4			3.175	40	62	10	51	51	48	6.6	M6*1	4	1137	2830	30
SFNU2510-3		10	4.762	40	62	12	70	51	48	6.6	M6*1	3	1399	2786	22
SFNU2510-4	4.762		40	62	12	80	51	48	6.6	M6*1	4	1792	3714	28	
SFNU3205-4	32	5	3.175	50	80	12	52	65	62	9	M6*1	4	1313	3861	37
SFNU3210-3		10	6.35	50	80	12	74	65	62	9	M6*1	3	2499	5366	30
SFNU3210-4			6.35	50	80	12	85	65	62	9	M6*1	4	3201	7154	40
SFNU4005-4	40	5	3.175	63	93	14	55	78	70	9	M8*1	4	1477	5042	46
SFU4010-3		10	6.35	63	93	14	71	78	70	9	M8*1	3	2895	7127	38
SFNU4010-4			6.35	63	93	14	88	78	70	9	M8*1	4	3707	9503	50
SFNU5010-4	50	10	6.35	75	110	16	88	93	85	11	M8*1	4	4219	12450	21
SFNU6310-4	63	10	6.35	90	125	18	93	108	95	11	M8*1	4	4815	16576	76
SFU6320-4		20	9.525	95	135	20	149	115	100	13.5	M8*1	4	7901	22662	77
SFU8010-4	80	10	6.35	105	145	20	98	125	110	13.5	M8*1	4	5336	21320	91
SFU8020-4		20	9.525	125	165	25	143	145	130	13.5	M8*1	4	9123	30621	96

2-4 Size Table of DFNU Ball Screws

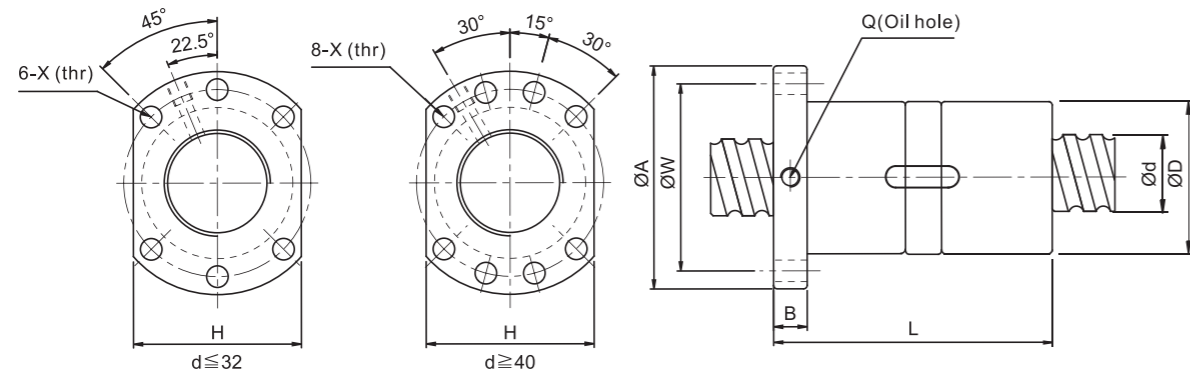

I:Lead Da:Ball Diameter n:Number of Circuits K:Stiffness(Kgf/μm)
 Ca:Basic Dynamic Rating Load(Kgf) Coa: Basic Static Rating Load(Kgf)

Unit:mm

Model no.	d	I	Da	Dimension									Load Rating Ca(kgf)	Load Rating Coa(kgf)	K kgf/μm
				D	A	B	L	W	H	X	Q	n			
DFNU1604-4	16	4	2.381	28	48	10	80	38	40	5.5	M6*1	4	655	1417	33
DFNU1605-4		5	3.175	28	48	10	91	38	40	5.5	M6*1	4	919	1789	33
DFNU1610-3		10	3.175	28	48	10	118	38	40	5.5	M6*1	3	669	1223	23
DFU2004-3	20	4	2.381	36	58	10	82	47	44	6.6	M6*1	4	589	1436	31
DFNU2005-4		5	3.175	36	58	10	95	47	44	6.6	M6*1	4	1065	2376	41
DFU2504-4	25	4	2.381	40	62	10	80	51	48	6.6	M6*1	4	663	1872	38
DFNU2505-4		5	3.175	40	62	10	95	51	48	6.6	M6*1	4	1137	2830	46
DFNU2510-4		10	4.762	40	62	12	138.5	51	48	6.6	M6*1	4	1792	3714	44
DFNU3205-4	32	5	3.175	50	80	12	97	65	62	9	M6*1	4	1313	3861	58
DFNU3210-4		10	6.35	50	80	12	153	65	62	9	M6*1	4	3201	7154	62
DFNU4005-4	40	5	3.175	63	93	14	96	78	70	9	M8*1	4	1477	5042	71
DFNU4010-4		10	6.35	63	93	14	157	78	70	9	M8*1	4	3707	9503	77
DFNU5010-4	50	10	6.35	75	110	16	157	93	85	11	M8*1	4	4219	12450	95
DFNU6310-4	63	10	6.35	90	125	18	182	108	95	11	M8*1	4	4815	16576	118
DFU6320-4		20	9.525	95	135	20	290	115	100	13.5	M8*1	4	7901	22662	119
DFU8010-4	80	10	6.35	105	145	20	182	125	110	13.5	M8*1	4	5336	21320	141
DFU8020-4		20	9.525	125	165	25	295	145	130	13.5	M8*1	4	9123	30621	149

Note:with sign ☆ can produce left helix

2-5 Size Table of OFNU Ball Screws

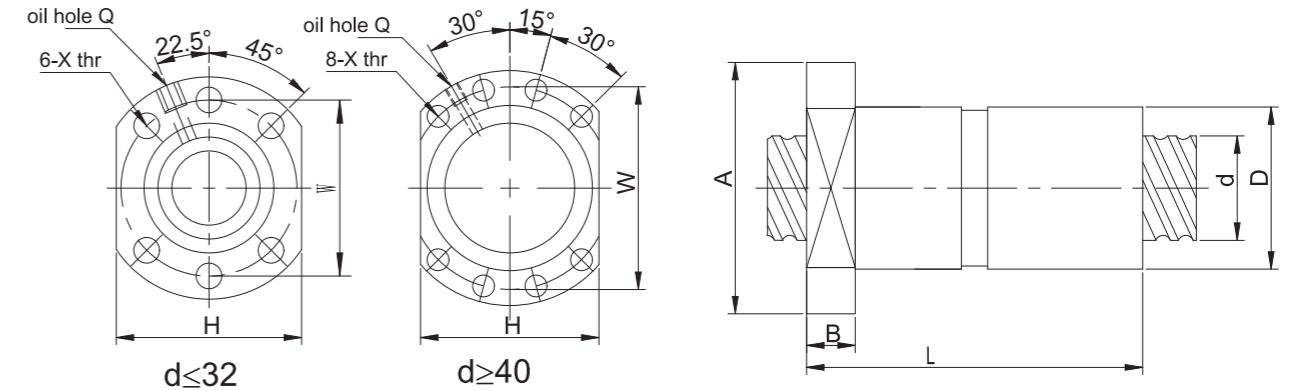

I:Lead Da:Ball Diameter n:Number of Circuits K:Stiffness(Kgf/μm)
 Ca:Basic Dynamic Rating Load(Kgf) Coa: Basic Static Rating Load(Kgf)

Unit:mm

Model no.	d	I	Da	Dimension									Load Rating Ca(kgf)	Load Rating Coa(kgf)	K kgf/μm
				D	A	B	L	W	H	X	Q	n			
OFNU1605-4	16	5	3.175	28	48	10	75	38	40	5.5	M6*1	8	919	1789	33
OFNU2005-4	20	5	3.175	36	58	10	85	47	44	6.6	M6*1	8	831	1782	31
OFNU2505-4	25	5	3.175	40	62	10	86	51	48	6.6	M6*1	8	1137	2830	46
OFNU2510-4		10	4.762	40	62	12	130	51	48	6.6	M6*1	8	1792	3714	44
OFNU3205-4	32	5	3.175	50	80	12	87	65	62	9	M6*1	8	1313	3861	58
OFNU3210-4		10	6.35	50	80	12	145	65	62	9	M6*1	8	3201	7154	62
OFNU4005-4	40	5	3.175	63	93	14	90	78	70	9	M8*1	8	1477	5042	71
OFNU4010-4		10	6.35	63	93	14	148	78	70	9	M8*1	8	3707	9503	77
OFNU5010-4	50	10	6.35	75	110	16	148	93	85	11	M8*1	8	4219	12450	95

2-6 Size Table of SFK Ball Screws

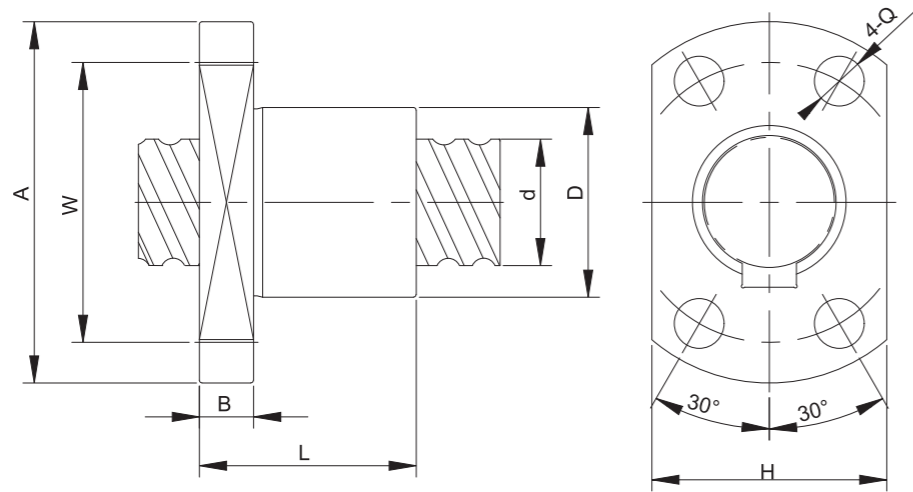

I:Lead Da:Ball Diameter n:Number of Circuits K:Stiffness(Kgf/μm)
Ca:Basic Dynamic Rating Load(Kgf) Coa: Basic Static Rating Load(Kgf)

Unit:mm

Model no.	d	I	Da	Dimension								Load Rating Ca(kgf)	Load Rating Coa(kgf)	K kgf/μm
				D	A	B	L	W	H	X	n			
SFK0601-4	6	1	0.8	12	24	4	14	18	16	3.4	1*4	93	170	12
SFK0801-4	8	1	0.8	14	27	4	14	21	18	3.4	1*4	110	245	16
SFK0802-4		2	1.2	14	27	5	24	21	18	3.4	1*4	183	340	16
SFK1002-4	10	2	1.2	18	35	5	24	27	22	4.5	1*4	214	466	21
SFK1202-4	12	2	1.2	20	37	5	24	29	24	4.5	1*4	234	572	24
SFK1204-4	12	4	2.5	24	40	6	28	32	25	3.5	1*3	521	861	28
SFK1402-4	14	2	1.2	21	40	6	24	31	26	5.5	1*4	251	677	28

2-7 Size Table of SFY Ball Screws

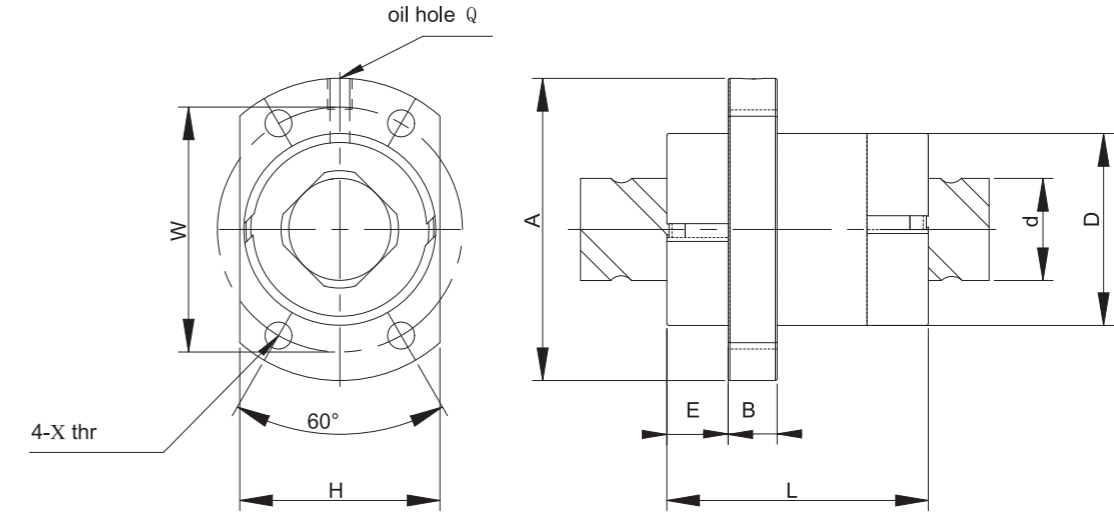

I:Lead Da:Ball Diameter n:Number of Circuits K:Stiffness(Kgf/μm)
Ca:Basic Dynamic Rating Load(Kgf) Coa: Basic Static Rating Load(Kgf)

单位:mm

Model no.	d	I	Da	D	A	E	B	L	W	H	X	Q	n	Load Rating Ca(kgf)	Load Rating Coa(kgf)	K kgf/μm
														Ca(kgf)	Coa(kgf)	K kgf/μm
SFY1616-3.6	16	16	2.778	32	53	10	10	45	42	34	4.5	M6*1	1.8*2	886	1994	24
SFY1632-1.6		32						0.8*2					419	915	10	
SFY2020-3.6	20	20	3.175	39	62	13	10	52	50	41	5.5	M6*1	1.8*2	1187	2894	30
SFY2040-1.6		40						0.8*2					556	1311	12	
SFY2040-3.6	20	40	3.175	39	62	13	10	90	50	41	5.5	M6*1	1.8*2	1117	2949	26
SFY2525-3.6		25						1.8*2					1773	4524	37	
SFY2525-5.6	25	25	3.969	47	74	15	12	89	60	49	6.6	M6*1	2.8*2	2593	7038	56
SFY2550-1.6		60						0.8*2					832	2050	15	
SFY2550-3.6		50						1.8*2					1671	4612	33	
SFY3232-3.6	32	32	4.762	58	92	17	12	78	74	60	9	M6*1	1.8*2	2508	6848	45
SFY3232-5.6		110						2.8*2					3667	10652	68	
SFY3264-1.6	32	64	4.762	58	92	17	12	71	74	60	9	M6*1	0.8*2	1172	3084	18
SFY4040-3.6	40	40	6.35	73	114	19.5	15	99	93	75	11	M6*1	1.8*2	4131	11587	57
SFY4040-5.6		139						2.8*2					6040	18024	86	
SFY4080-1.6		80						0.8*2					1939	5253	23	
SFY5050-3.6	50	50	7.938	90	135	21.5	20	117	112	92	14	M6*1	1.8*2	6185	18032	70
SFY5050-5.6		167						2.8*2					9044	28049	106	
SFY50100-1.6	50	100	7.938	90	135	21.5	20	111	112	92	14	M6*1	0.8*2	2803	7793	27

2-8 Size Table of SFNI Ball Screws

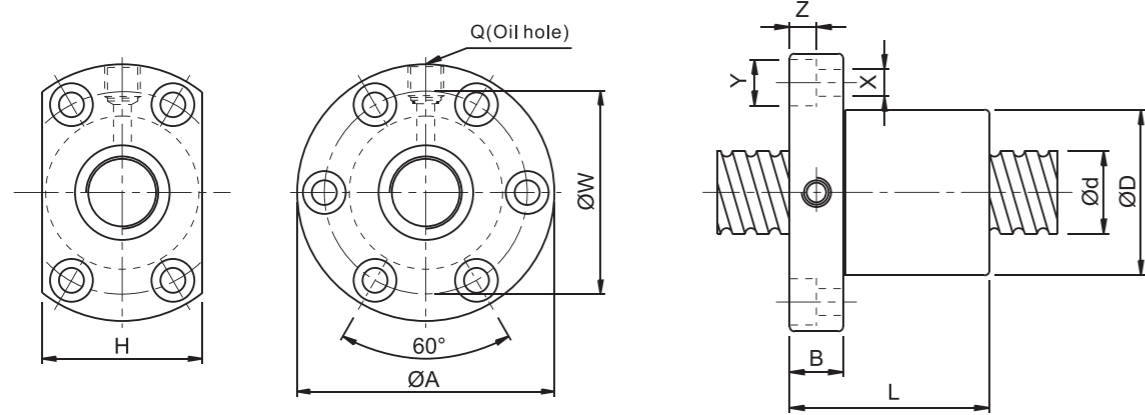

I:Lead Da:Ball Diameter n:Number of Circuits K:Stiffness(Kgf/μm)
 Ca:Basic Dynamic Rating Load(Kgf) Coa: Basic Static Rating Load(Kgf) Unit:mm

Model no.	d	I	Da	Dimension											Load Rating Ca(kgf)	Load Rating Coa(kgf)	K kgf/μm
				D	A	B	L	W	H	X	Y	Z	Q	n			
☆ SFNI1605-4	16	5	3.175	30	49	10	45	39	34	4.5	8	4.5	M6*1	4	919	1789	21
☆ SFNI1610-3		10	3.175	34	58	10	57	45	34	5.5	9.5	5.5	M6*1	3	669	1223	14
☆ SFNI2005-4	20	5	3.175	34	57	11	51	45	40	5.5	9.5	5.5	M6*1	4	1065	2376	26
☆ SFNI2505-4	25	5	3.175	40	63	11	51	51	46	5.5	9.5	5.5	M8*1	4	1137	2830	30
☆ SFNI2510-4		10	4.762	46	72	12	80	58	52	6.5	11.5	6.5	M6*1	4	1792	3714	28
☆ SFNI3205-4	32	5	3.175	46	72	12	52	58	52	6.5	11.5	6.5	M8*1	4	1313	3861	37
☆ SFNI3210-4		10	6.35	54	88	15	85	70	62	9	14	9	M8*1	4	3201	7154	40
☆ SFNI4005-4	40	5	3.175	56	90	15	55	72	64	9	14	8.5	M8*1	4	1477	5042	46
☆ SFNI4010-4		10	6.35	62	104	18	88	82	70	11	17.5	11	M8*1	4	3707	9503	50
☆ SFNI5010-4	50	10	6.35	72	114	18	88	92	82	11	17.5	11	M8*1	4	4219	12450	61
☆ SFNI6310-4	63	10	6.35	85	131	22	93	107	95	14	20	13	M8*1	4	4815	16576	76
☆ SFNI8010-4	80	10	6.35	105	150	22	93	127	115	14	20	13	M8*1	4	5336	21320	91

Note:with sign ☆ can produce left helix

2-9 Size Table of OFNI Ball Screws

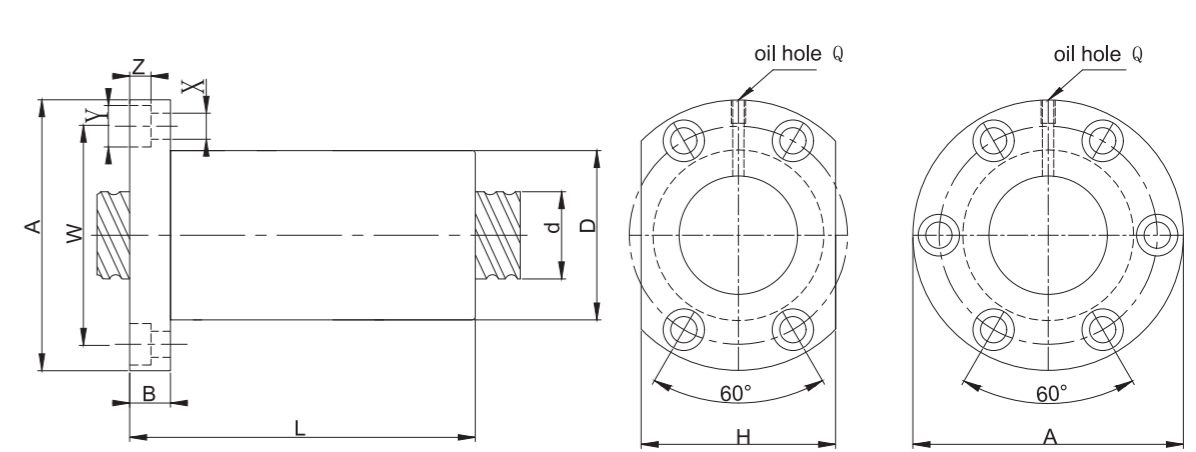

I:Lead Da:Ball Diameter n:Number of Circuits K:Stiffness(Kgf/μm)
 Ca:Basic Dynamic Rating Load(Kgf) Coa: Basic Static Rating Load(Kgf) Unit:mm

Model no.	d	I	Da	Dimension											Load Rating Ca(kgf)	Load Rating Coa(kgf)	K kgf/μm
				D	A	B	L	W	H	X	Y	Z	Q	n			
☆ OFNI1605-4	16	5	3.175	30	49	10	75	39	34	4.5	8	4.5	M6*1	8	919	1789	33
☆ OFNI2005-4	20	5	3.175	34	57	11	85	45	40	5.5	9.5	5.5	M6*1	8	1065	2376	41
☆ OFNI2505-4	25	5	3.175	40	63	11	86	51	46	5.5	9.5	5.5	M8*1	8	1137	2830	46
☆ OFNI2510-4		10	4.762	46	72	12	130	58	52	6.5	11.5	6.5	M6*1	8	1792	3714	44
☆ OFNI3205-4	32	5	3.175	46	72	12	87	58	52	6.5	11.5	6.5	M8*1	8	1313	3861	58
☆ OFNI3210-4		10	6.35	54	88	15	145	70	62	9	14	9	M8*1	8	3201	7154	62
☆ OFNI4005-4	40	5	3.175	56	90	15	90	72	64	9	14	8.5	M8*1	8	1477	5042	71
☆ OFNI4010-4		10	6.35	62	104	18	148	82	70	11	17.5	11	M8*1	8	3707	9503	77
☆ OFNI5010-4	50	10	6.35	72	114	18	148	92	82	11	17.5	11	M8*1	8	4219	12450	95
☆ OFNI6310-4	63	10	6.35	85	131	22	153	107	95	14	20	13	M8*1	8	4815	16576	118
☆ OFNI8010-4	80	10	6.35	105	150	22	153	127	115	14	20	13	M8*1	8	5336	21320	141

Note:with sign ☆ can produce left helix

Support

The support seat is the bearing fixed seat connecting the screw rod and the motor. It is the shaft end product of the standard ball screw. Support units are composed of a bearing housing, bearing, holding lid, seal, lock nut and set screws. The support unit can be used on Fixed and supported ends for the ball screw, which mounts the ball screw in the desired position. Limon offers various ball screw support units to satisfy the mounting or loading requirements of any application. The support unit can be used in the fixed end and the support end of the ball screw respectively to fix the screw in the correct position. It is compact in size, easy to install, and can be installed in a narrow space. Because the bearing already contains proper grease and is adjusted to the proper condition, it can be assembled to the equipment immediately without additional adjustment and processing, so as to reduce the assembly time and improve the accuracy and stability of assembly.

1-1 General Feature

Limon's support provide accurate and repeatable linear motion with precise positioning control. Combining a ballscrew, nut and bearing, plus additional components such as end supports, which have high axial load capacity and run smoothly and efficiently.

1 Support Classification

1-1 BK Fixed Side

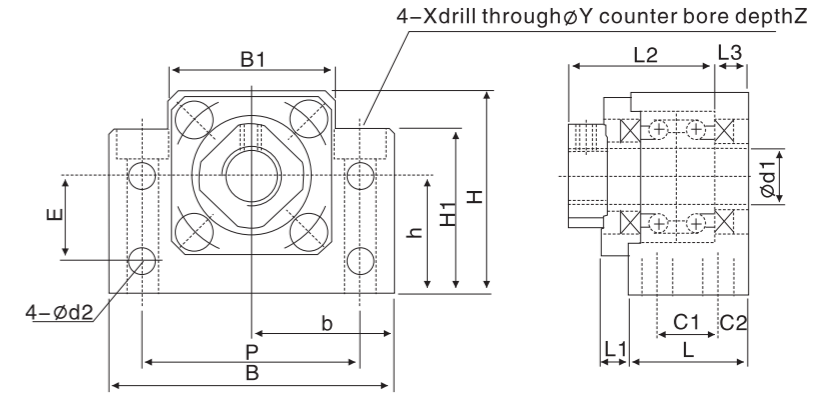

Unit:mm

Model Number	d1	L	L1	L2	L3	C1	C2	B	H	b ^{±0.02}	h ^{±0.02}	B1	H1	E	P	d2	X	Y	Z
BK 10	10	25	5	29	5	13	6	60	39	30	22	34	32.5	15	46	5.5	6.6	10.8	5
BK 12	12	25	5	29	5	13	6	60	43	30	25	34	32.5	18	46	5.5	6.6	10.8	1.5
BK 15	15	27	6	32	6	15	6	70	48	35	28	40	38	18	54	5.5	6.6	11	6.5
BK 17	17	35	9	44	7	19	8	86	64	43	39	50	55	28	68	6.6	9	14	8.5
BK 20	20	35	8	43	8	19	8	88	60	44	34	52	50	22	70	6.6	9	14	8.5
BK 25	25	42	12	54	9	22	10	106	80	53	48	64	70	33	85	9	11	17.5	11
Bk 30	30	45	14	61	9	23	11	128	89	64	51	76	78	33	102	11	14	20	13
Bk 35	35	50	14	67	12	26	12	140	96	70	52	88	79	35	114	11	14	20	13
BK 40	40	61	18	76	15	33	14	160	110	80	60	100	90	37	130	14	18	26	17.5

BF Floated Side

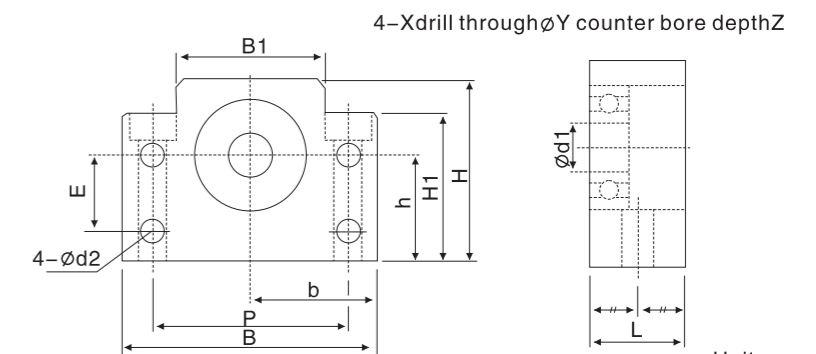

Unit:mm

Model Number	d1	L	B	H	b ^{±0.02}	h ^{±0.02}	B1	H1	E	P	d2	X	Y	Z
BF 10	8	20	60	39	30	22	34	32.5	15	46	5.5	6.6	10.8	5
BF 12	10	20	60	43	30	25	34	32.5	18	46	5.5	6.6	10.8	1.5
BF 15	15	20	70	48	35	28	40	38	18	54	5.5	6.6	11	6.5
BF 17	17	23	86	64	43	39	50	55	28	68	6.6	9	14	8.5
BF 20	20	26	88	60	44	34	52	50	22	70	6.6	9	14	8.5
BF 25	25	30	106	80	53	48	64	70	33	85	9	11	17.5	11
BF 30	30	32	128	89	64	51	76	78	33	102	11	14	20	13
BF 35	35	32	140	96	70	52	88	79	35	114	11	14	20	13
BF 40	40	37	160	110	80	60	100	90	37	130	14	18	26	17.5

Support - EK/EF Series



Support - FK/FF Series

1-2 EK Fixed Side

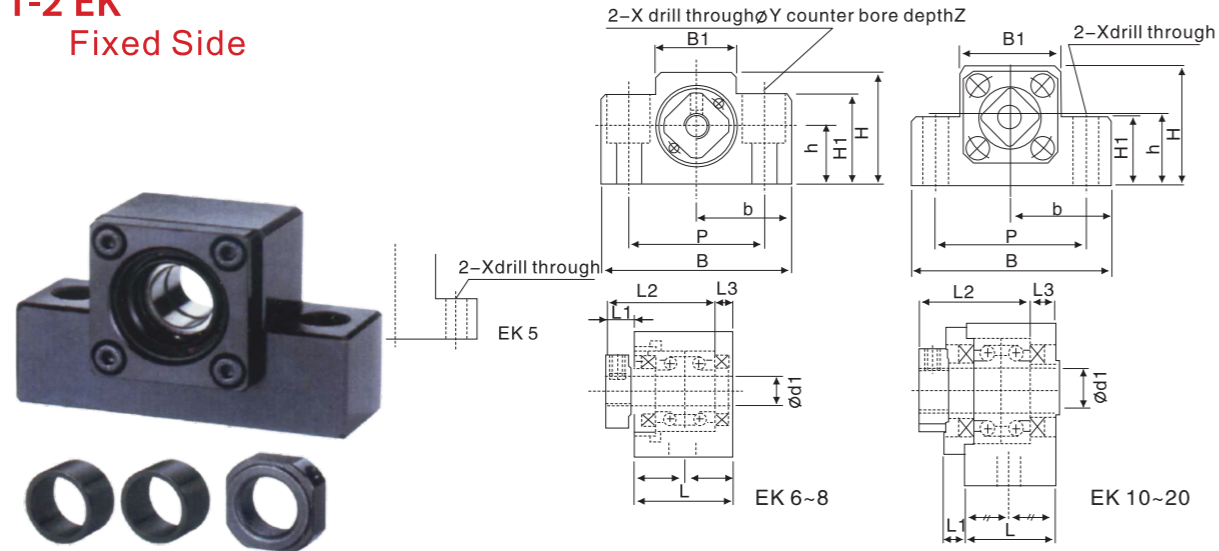

Unit:mm

Model Number	d1	L	L1	L2	L3	B	H	b ^{±0.02}	h ^{±0.02}	B1	H1	P	X	Y	Z
EK 5	5	16.5	5.5	18.5	3.5	36	21	18	11	20	8	28	4.5	-	-
EK 6	6	20	5.5	22	3.5	42	25	21	13	18	20	30	5.5	9.5	11
EK 8	8	23	7	26	4	52	32	26	17	25	26	38	6.6	11	12
EK 10	10	24	6	29.5	6	70	43	35	25	36	24	52	9	-	-
EK 12	12	24	6	29.5	6	70	43	35	25	36	24	52	9	-	-
EK 15	15	25	6	36	5	80	49	40	30	41	25	60	11	-	-
EK 20	20	42	10	50	10	95	58	47.5	30	56	25	75	11	-	-

EF Floated Side

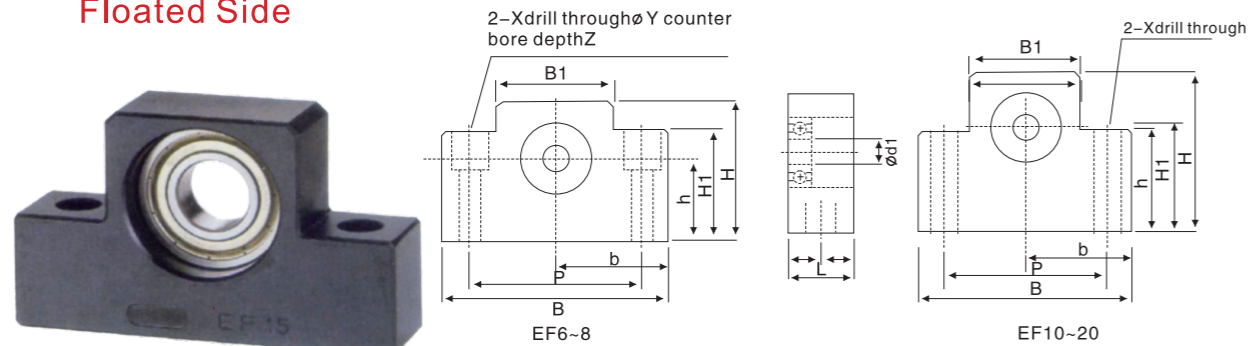

Unit:mm

Model Number	d1	L	B	H	b ^{±0.02}	h ^{±0.02}	B1	H1	P	X	Y	Z
EF 6	6	12	42	25	31	13	18	20	30	5.5	9.5	11
EF 8	6	14	52	32	26	17	25	26	38	6.6	11	12
EF 10	8	20	70	43	35	25	36	24	52	9	-	-
EF 12	10	20	70	43	35	25	36	24	52	9	-	-
EF 15	15	20	80	49	40	30	41	25	60	9	-	-
EF 20	20	26	95	58	47.5	30	56	25	75	11	-	-

1-3 FK Fixed Side

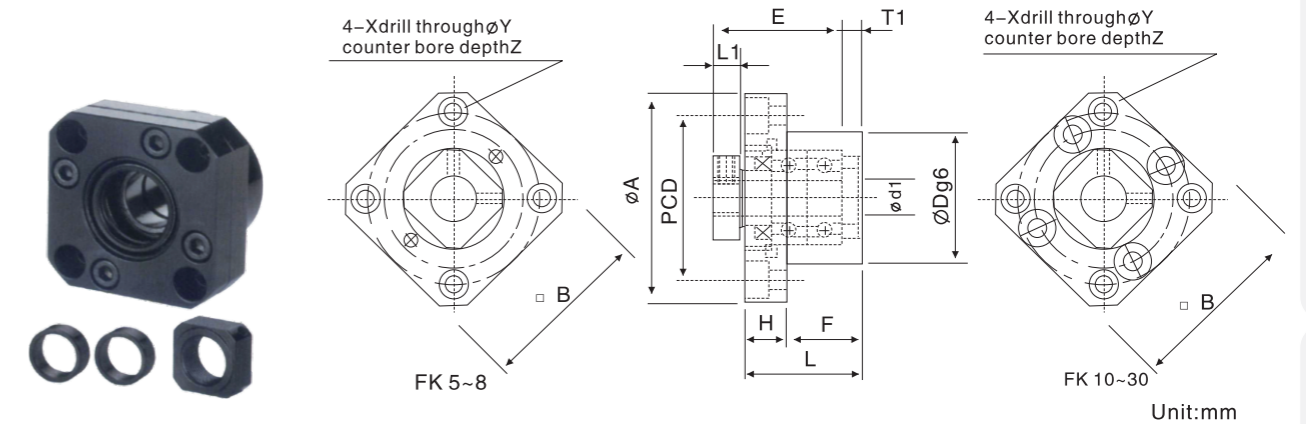

Unit:mm

Model Number	d1	L	H	F	E	Dg6	A	PCD	B	L1	T1	X	Y	Z
FK 5	5	16.5	6	10.5	18.5	20	34	26	26	5.5	3.5	3.4	6.5	4
FK 6	6	20	7	13	22	22	36	28	28	5.5	3.5	3.4	6.5	4
FK 8	8	23	9	14	26	28	43	35	35	7	4	3.4	6.5	4
FK 10	10	27	10	17	29.5	34	52	42	42	7.5	5	4.5	8	4
FK 12	12	27	10	17	29.5	36	54	44	44	7.5	5	4.5	8	4
FK 15	15	32	15	17	36	40	63	50	52	10	6	5.5	9.5	6
FK 17	17	45	22	23	47	50	77	62	61	11	9	6.6	11	10
FK 20	20	52	22	30	50	57	85	70	68	8	10	6.6	11	10
FK 25	25	57	27	30	60	63	98	80	79	13	10	9	15	13
FK 30	30	62	30	32	61	75	117	95	93	11	12	11	17.5	15

FF Floated Side

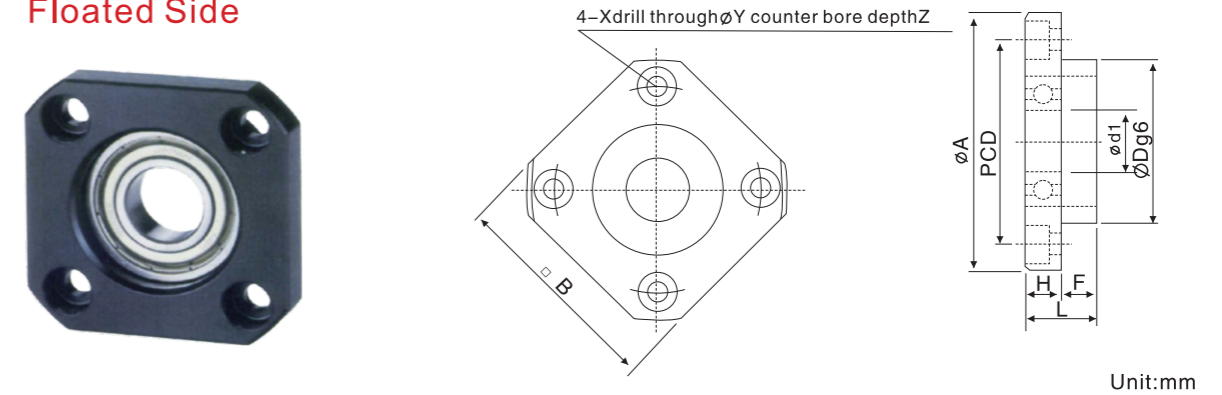

Unit:mm

Model Number	d1	L	H	F	Dg6	A	PCD	B	X	Y	Z
FF 6	6	10	6	4	22	36	28	28	3.4	6.5	4
FF 10	8	12	7	5	28	43	35	35	3.4	6.5	4
FF 12	10	15	7	8	34	52	42	42	4.5	8	4
FF 15	15	17	9	8	40	63	50	52	5.5	9.5	5.5
FF 17	17	20	11	9	50	77	62	61	6.6	11	6.5
FF 20	20	20	11	9	57	85	70	68	6.6	11	6.5
FF 25	25	24	14	10	63	98	80	79	9	14	8.5
FF 30	30	27	18	9	75	117	95	93	11	17.5	11

Linear Guideways

Ball Screw

Support

Linear Bushing

Linear Guideways

Ball Screw

Support

Linear Bushing

1-4 Support Unit AK (fixed-side rectangular type)

Park No.	Part name	Qty
1	Housing	1
2	Bearing	set
3	Holding lid	1
4	Collar	2
5	Seal	1
6	Lock nut	set
7	Hexagon socket-head screws	2

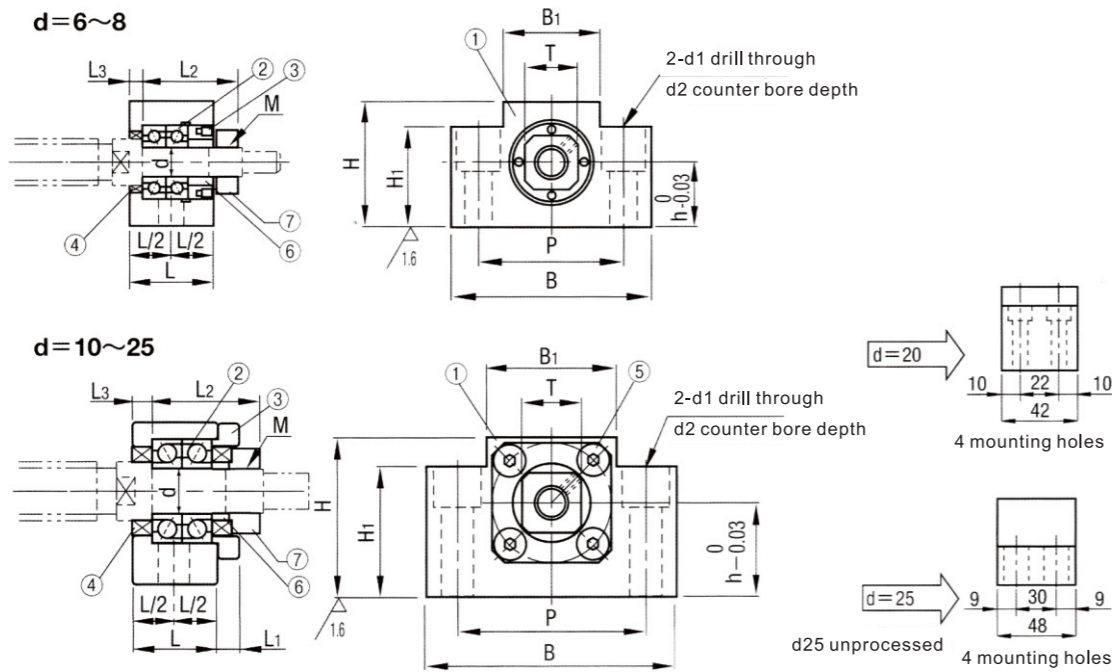

Unit:mm

Model Number	Shaft diameter d1	L	L1	L2	L3	B	H	h	B1	H1	P	d1	d2	e	M (screw thread)	T	Oil Seal (Applicable axle dia.)
AK6	6	20	-	22.5	3.5	42	25	13	18	20	30	5.5	9.5		M6×0.75	12	-
AK8	8	23	-	26	4	52	32	17	25	26	38	6.6	11		M8×1.0	14	10 11.54
AK10	10	24	6	29.5	6	6	40	22		32				11	M10×1.0	17	14
							43	25	36	35	52	9	14				14
AK12	12						41	23		33					M12×1.0	19	15
							43	25		35							
							46	26		36							
AK15	15	25	6	38	5	80	48	28	41	38				M15×1.0	22	20	
							50	30	60	40							
							58	33	75	45	11	17	15				
AK20	20	42	10	52	10	95	58	30	56	45	75			M20×1.0	30	25	
AK25	25	48	13	59	14	105	68	35	66	25	85	11	-	M25×1.5	35	31	

- Note:
- The use of C7 (prefix 6) deep groove ball bearing maximum axial clearance of 0.05-0.1mm.
 - The use of C5 (prefix 7) by pre-loading angular contact bearings, axial clearance 0.
 - The bearing is made of German brand, which is assembled by DF.

Support Unit AF (Supported-side rectangular type)

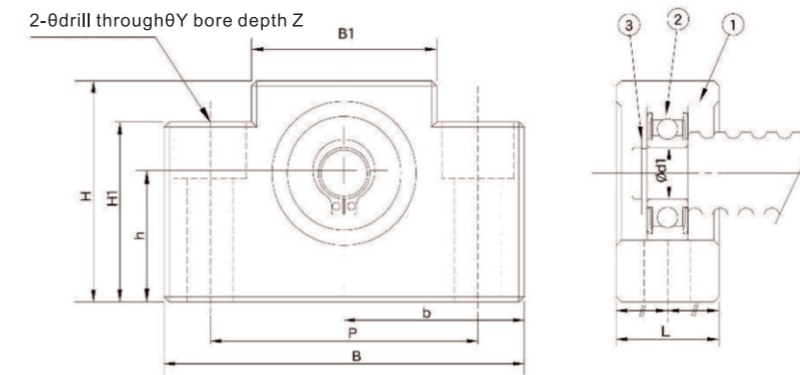

Unit:mm

Model Number	Shaft diameter d1	L	B	H	b	h	B1	H1	P	X	Y	Z	Bearing	Snapping	Weight (kgs)
AF10	8	20	70	43	35	25	36	35	52	9	14	11	608ZZ	S08	0.37
AF12	10	20	70	43	35	25	36	35	52	9	14	11	6000ZZ	S10	0.37
AF15	15	20	80	49	40	30	41	40	60	9	14	11	6002ZZ	S15	0.45
AF20	20	26	95	58	47.5	30	56	45	75	11	17	15	6204ZZ	S20	0.75
AF25	25	30	105	68	52.5	35	66	25	85	11	-	-	6205ZZ	S25	0.95

- Note:
- The use of (prefix 6) deep groove ball bearing maximum axial clearance of 0.05-0.01mm.

1-5 Recommended ball screw end machining size

Fixed side

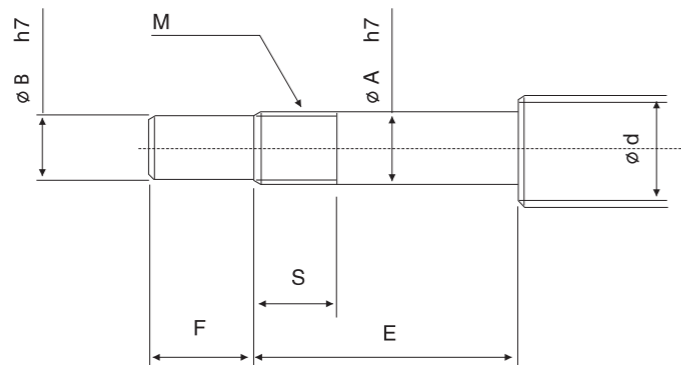

Unit:mm

Model Number	Ball Screw shaft OD	Shaft Support Portion OD					Metric screw thread	
Type BK	d	A	B	E	F	M	S	
BK 10	12/14/15	10	8	36	15	M10×1	16	
BK 12	14/15/16	12	10	36	15	M12×1	14	
BK 15	18/20	15	12	40	20	M15×1	12	
BK 17	20/25	17	15	53	23	M17×1	17	
BK 20	25/28	20	17	53	25	M20×1	15	
BK 25	32/36	25	20	65	30	M25×1.5	18	
BK 30	36/40	30	25	72	38	M30×1.5	25	
BK 35	45	35	30	81	45	M35×1.5	18	
BK 40	50	40	35	93	50	M40×1.5	35	

Unit:mm

Model Number	Ball Screw shaft OD	Shaft Support Portion OD					Metric screw thread	
Type FK	Type FK	d	A	B	E	F	M	S
FK 6	EK6	8	6	4	28	8	M6×0.75	8
FK 8	EK8	10/12	8	6	32	9	M8×1	10
FK 10	EK10	12/14/15	10	8	36	15	M10×1	11
FK 12	EK12	14/15/16	12	10	36	15	M12×1	11
FK 15	EK15	18/20	15	12	47	20	M15×1	13
FK 17	-	20/25	17	15	58	23	M17×1	15
FK 20	EK20	25/28/30	20	17	62	25	M20×1	17
FK 25	-	30/32/36	25	20	76	30	M25×1.5	20
FK 30	-	36/40	30	25	72	38	M30×1.5	25

Recommended ball screw end machining size

Floated Side

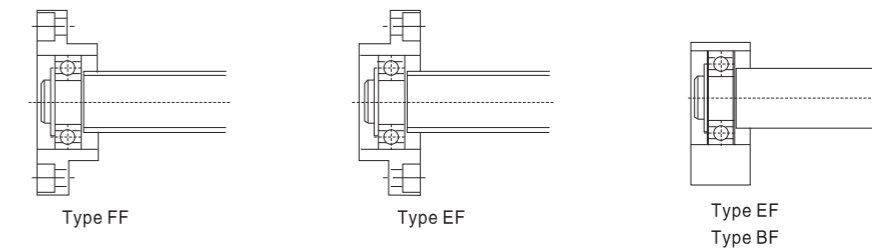

Model Number			Ball Screw shaft OD	Shaft Support Portion OD
Type FF	Type EF	Type BF	d	A
FF10	EF10	BF10	12/14/15	8
FF12	EF12	BF12	14/15/16	10
FF15	EF15	BF15	18/20	15
FF17	-	BF17	20/25	17
FF20	EF20	(BF20)NOTE	25/28/30	20
FF25	-	BF25	30/32/36	25
FF30	-	BF30	36/40	30
-	-	BF35	40/45	35
-	-	BF40	50	40

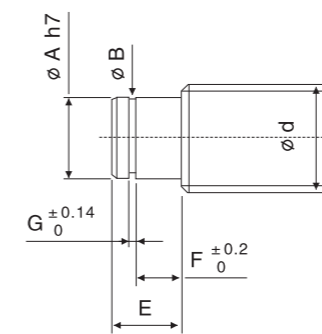

Note:
In this table, dimensions in parentheses are those of type BF20. These dimensions differ from those of type FF20 and EF20. When placing an order, always specify the model number of the Support Unit to be used

Unit:mm

Snap-ring Groove			
E	B	F	G
10	7.6	7	0.9
11	9.6	8	1.15
13	14.3	9	1.15
16	16.2	12	1.15
19(16)	19	14(12)	1.35
20	23.9	15	1.35
21	28.6	16	1.75
22	33	17	1.75
23	38	18	1.75

1-6 WBK High Load Support

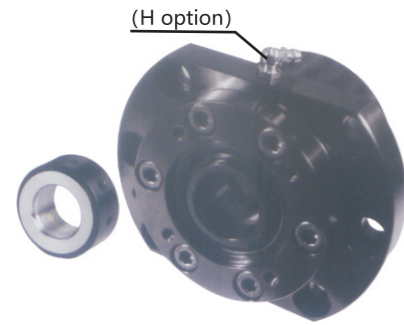

Park No.	Part name	Qty
1	Housing	1
2	Bearing	1 set
3	Holding lid	1
4	Collar	2
5	Seal	2
6	Lock nut	1 set
7	Hexagon socket-head Setscrew	4

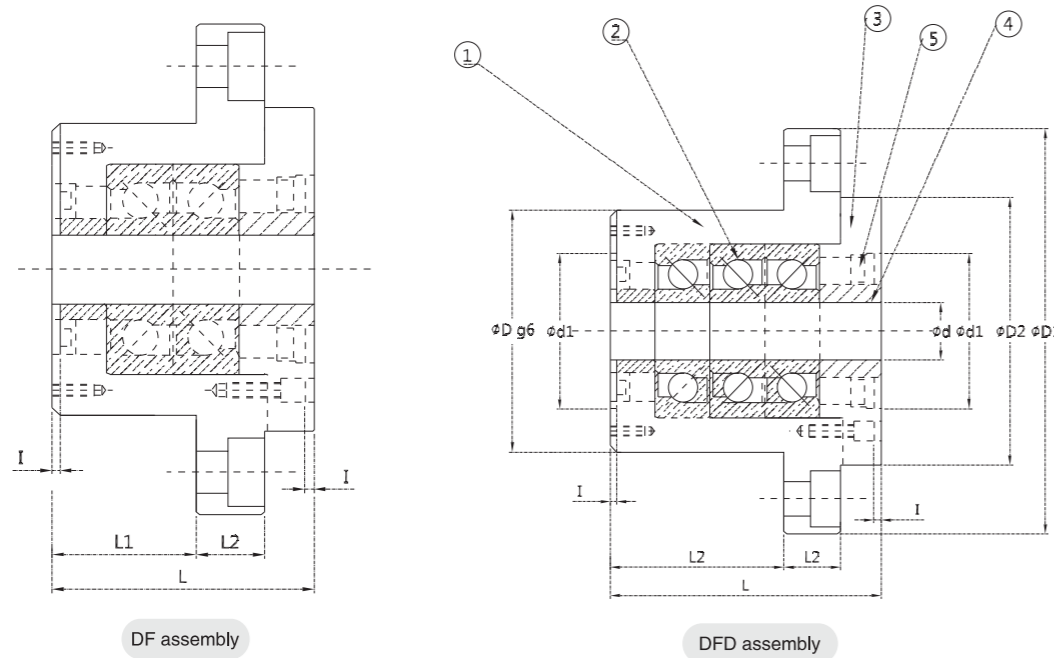

Model Number	Dimensions of support unit																	
	d	D	D1	D2	L	L1	L2	A	W	X	Y	Z	d1	I	V	P	Q	H
WBK 17DF	17	70	106	72	60	32	15	80	88	9	14	8.5	45	3	58	M5	10	M6
WBK 20DF	20	70	106	72	60	32	15	80	88	9	14	8.5	45	3	58	M5	10	M6
WBK 25DF					66	33												
WBK 25DFD	25	85	130	90	81	48	18	100	110	11	17	11	57	4	70	M6	12	M6
WBK 25DFF					96	48												
WBK 30DF					66	33												
WBK 30DFD	30	85	130	90	81	48	18	100	110	11	17	11	57	4	70	M6	12	M6
WBK 30DFF					96	48												
WBK 35DF					66	33												
WBK 35DFD	35	95	142	102	81	48	18	106	121	11	17	11	69	4	80	M6	12	M6
WBK 35DFF					96	48												
WBK 40DF					66	33												
WBK 40DFD	40	95	142	102	81	48	18	106	121	11	17	11	69	4	80	M6	12	M6
WBK 40DFF					96	48												

Note:
Inside bearings use high precision P4 grade TAC 60 degree contact ball bearing.
The standard type is without H, if required, please advise in advance.

WBK High Load Support

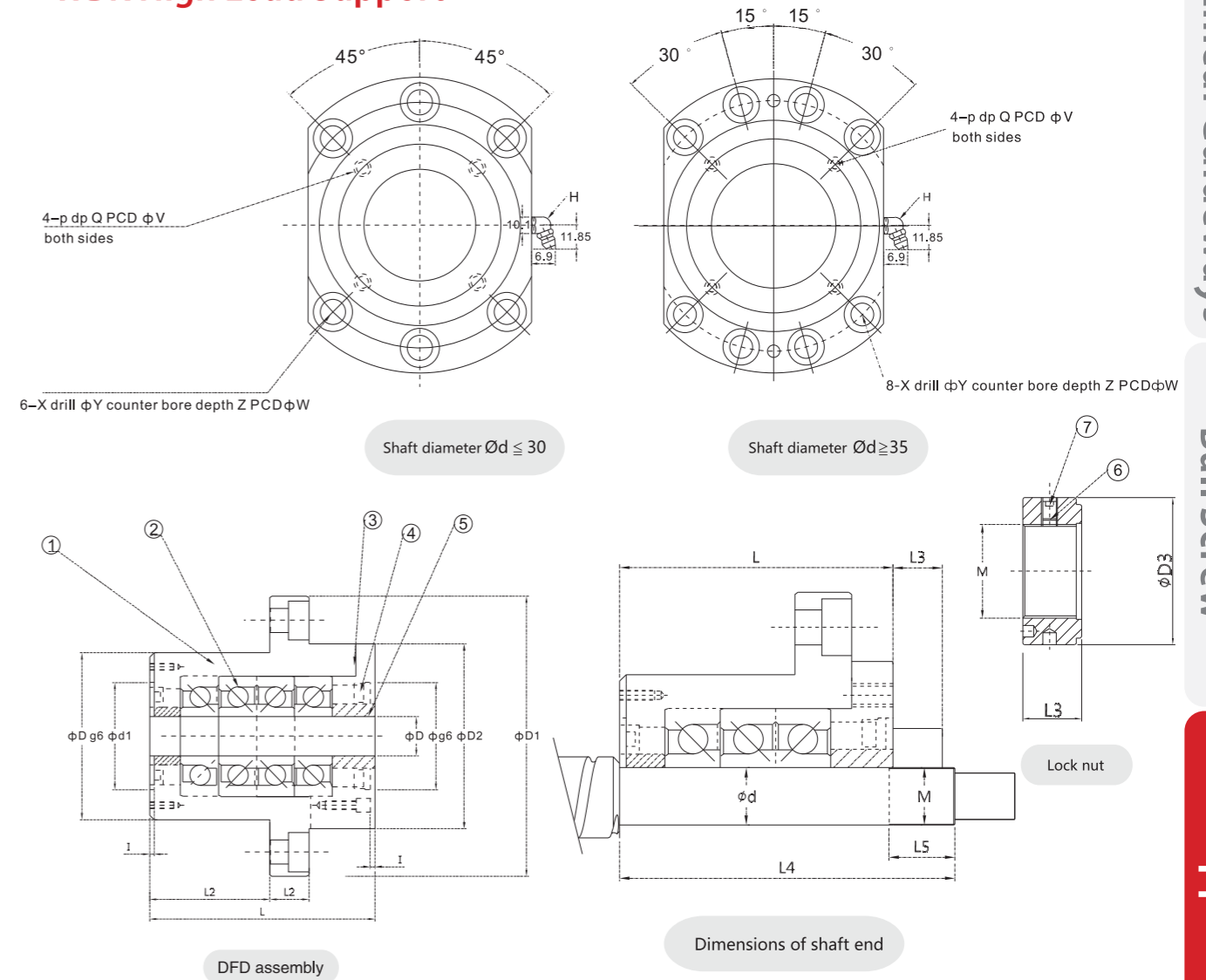

Model Number	Basic dynamic load rating Ca(kgf)	Permissible axial load (kgf)	Preload (kgf)	Axial rigidity (kgf/um)	Starting torque (kgf-cm)	Lock nut			Weight (kgs)	Dimensions of shaft end		
						M	D3	L3		d	L4	L5
WBK 17DF	2240	2710	220	75	1~1.9	M17×1	37	18	1.97	17	81	23
WBK 20DF	2240	2710	220	75	1~1.9	M20×1	40	18	1.97	20	81	23
WBK 25DF	2910	4150	320	100	1.6~2.9				3.3		89	
WBK 25DFD	4700	8300	440	150	2.2~4	M25×1.5	45	20	3.85	25	104	26
WBK 25DFF	4700	8300	640	200	2.8~5				4.4		119	
WBK 30DF	2980	4400	340	105	1.7~3				3.4		89	
WBK 30DFD	4850	8800	460	155	2.2~4	M30×1.5	50	20	3.7	30	104	26
WBK 30DFF	4850	8800	680	205	2.9~5.2				4.4		119	
WBK 35DF	3150	5100	390	120	1.9~3.5				3.75		92	
WBK 35DFD	5150	10200	530	175	2.5~4.6	M35×1.5	55	22	4.4	35	107	30
WBK35DFF	5150	10200	780	240	3.3~6				5		122	
WBK 40DF	3250	5300	400	125	2~3.7				3.65		92	
WBK 40DFD	5250	10600	540	185	2.4~4.0	M40×1.5	60	22	4.3	40	107	30
WBK 40DFF	5250	10600	800	245	3.4~6.2				5		122	

Note:
Dimensions with * mark can be used for dust cover and damper installation.
About its correct position, please contact SYK.

1-7 DSG Ball Screw Nut Support

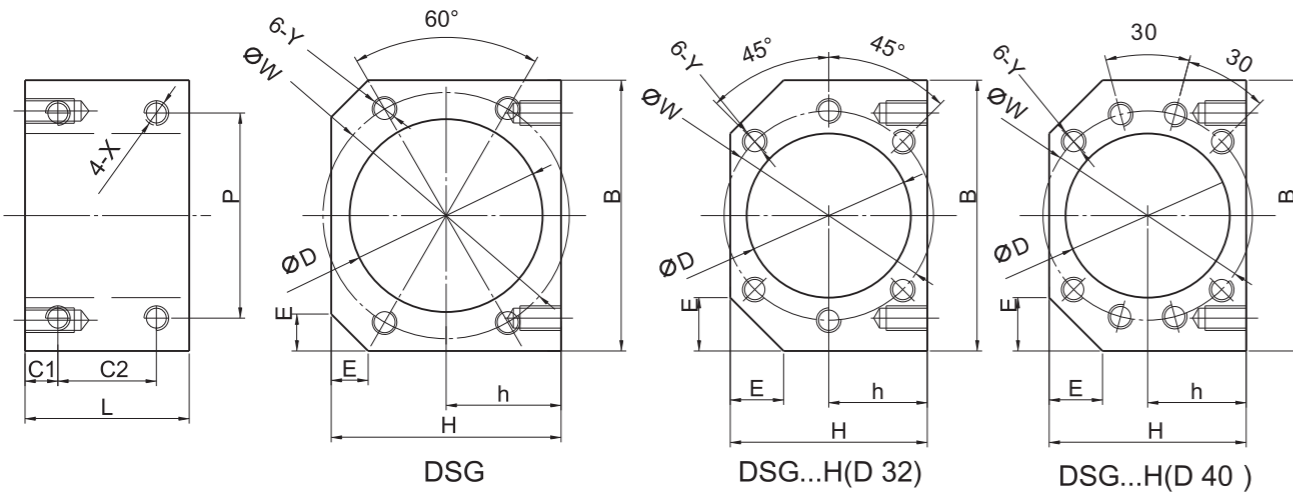

Model Number	Suitable Nut	D	B	H	h	E	L	C1	C2	P	X	W	Y
DSG12H	SFU1204,SFS1205	22.1 24.1	50	35	17.7	-	36	8	24	36	M4	32	M4
DSG16H	SFU-1604,1605,1610	28	52	40	20	12	40	8	24	40	M5	38	M5
	SFS-1610,1616,1620												
DSG20H	SFU-2004,2005	36	62	44	22	12	40	8	24	48	M6	47	M6
	SFS-2010,2020												
DSG25H	SFU-2504,2505,2510	40	66	48	24	13	40	8	24	50	M6	51	M6
	SFS-2505,2510,2520												
DSG32H	SFU-3204,3205,3210	50	86	62	31	17	40	8	24	66	M8	65	M8
	SFS-3205,3210,3220,3232												
DSG40H	SFU-4005,4010,	63	100	80	40	/	59	9.5	40	78	M8	78	M8
	SFS-4005,4010,4020,4040												
DSG50H	SFU-5005,5010	75	120	90	45	/	60	10	40	100	M10	93	M10
	SFS-5020,5050												
DSG1616	SFE/SFY-1616	32	55	40	20	6	27	6	15	46	M4	42	M4
DSG2020	SFE/SFY-2020	39	66	47	23.5	7.5	35	7.5	20	56	M5	50	M5
DSG2525	SFE/SFY-2525	47	80	55	27.5	10	34	7	20	68	M6	60	M6
DSG3232	SFE/SFY-3232	58	95	66	33	10	55	10	35	82	M8	74	M8

1 General Information

1-1 Structure

The LIMON linear motion bearing consists of an outer cylinder, ball retainer, balls and two end rings. The ball retainer which holds the balls in the recirculating tracks is held inside the outer cylinder by end rings.

Those parts are assembled to optimize their required functions. The outer cylinder is maintained sufficient hardness by heat treatment, therefore it ensures the bearings projected travel life and satisfactory durability.

The ball retainer is made from steel or synthetic resin. The steel retainer has high rigidity.

The synthetic resin retainer can reduce running noise. The user can select the optimum type for meeting the user's service conditions.

1-2 Features

1-2-1 High precision and rigidity

The LIMON linear motion bearing is produced from a solid steel outer cylinder and incorporates an industrial strength resin retainer.

1-2-2 Easy of assembly

The standard type of LIMON linear motion bearing can be loaded from any direction. Precision control is possible using only the shaft supporter, and the mounting surface can be machined easily.

1-2-3 Easy of replacement

LIMON linear motion bearings of each type are completely interchangeable because of their standardized dimensions and strict precision control. Replacement because of wear or damage is therefore easy and accurate.

1-2-4 Variety of types

LIMON offers a full line of linear motion bearings: the standard, integral single retainer closed types and the open, double retainer, and flanged types. The user can choose from among these according to the application requirements to be met.

1-3 Type Number Format

1-3-1 Linear Motion Bearing

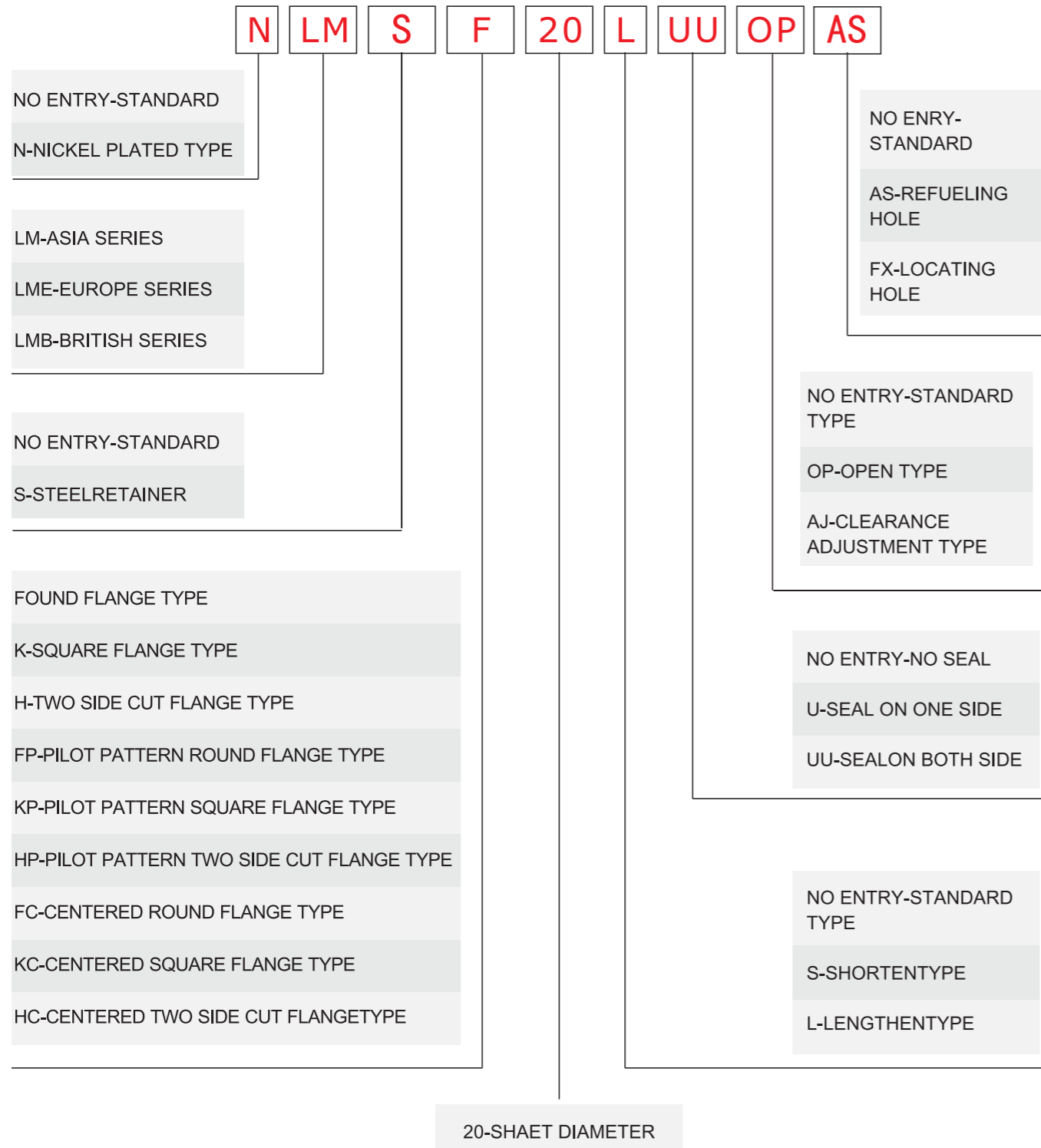

1-3-2 Slide Unit

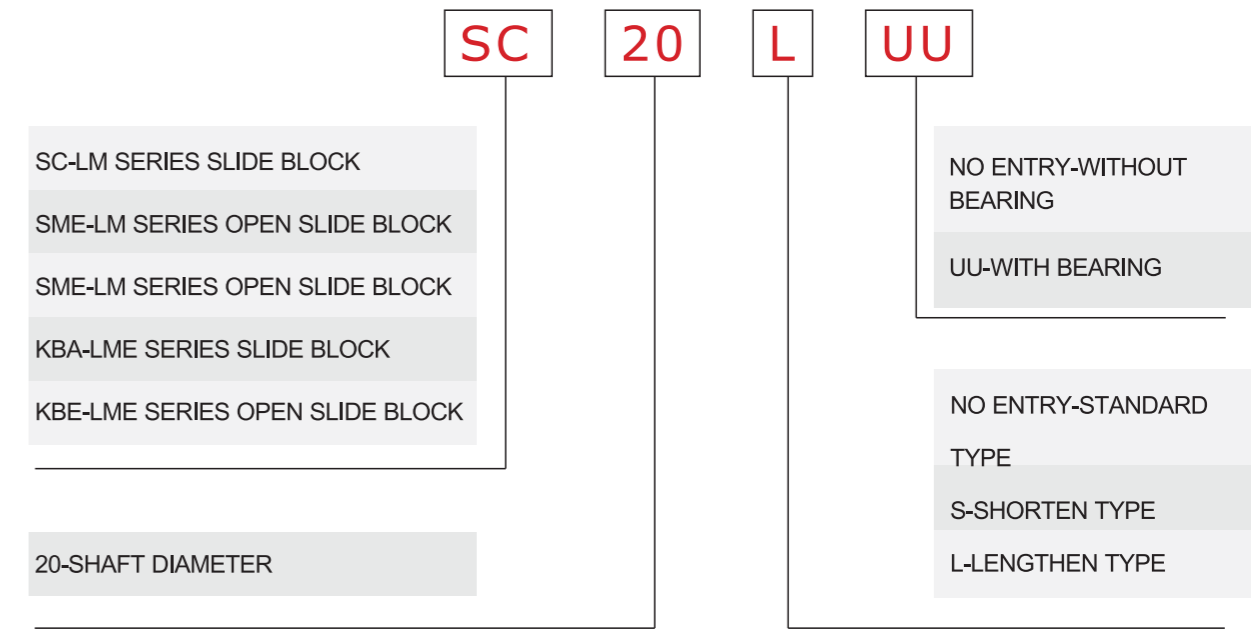

1-4 Load

1-4-1 Basic Dynamic Load Rating(C)

This term is arrived at based on an evaluation of a number of identical linear systems individually run in the same conditions, if 90% of them can run with the load (with a constant value in a constant direction) for a distance of 50 km without damage caused by rolling fatigue. This is the basis of the rating

1-4-2 Basic Static Load Rating(Co)

This term defines a static load such that, at the contacting position where the stress is exercised, the sum of the permanent deformation of the rolling elements and that of the rolling plane is 0.0001 time of the diameter of the rolling elements

1-4-3 Relation Between Ball Circuits and Load Rating

The LIMON linear motion bearing includes ball circuits that are spaced equally and circumferentially. The load rating varies according to the loaded position on the circumference. The value in the dimension table indicates the load rating when the

load is placed on top of one ball circuit. If the LIMON linear bearing is used with two ball circuits loaded uniformly, the load rating will be greater, the following table shows the values by the number of ball circuits in such cases:

Table 1

Number of rows	3	4	5	6	8
Row position load ratio					
Row position	$Q_0 = P_0$	$Q_1 = P_0$	$Q_1 = 1.106 P_0$	$Q_1 = 1.354 P_0$	$Q_1 = 1.841 P_0$
Row position	$Q_0 = P_0$	$Q_0 = 1.414 P_0$	$Q_0 = 1.618 P_0$	$Q_0 = 1.732 P_0$	$Q_0 = 2.052 P_0$
Load ratio	$Q_0/Q_1 = 1$	$Q_0/Q_1 = 1.414$	$Q_0/Q_1 = 1.463$	$Q_0/Q_1 = 1.280$	$Q_0/Q_1 = 1.115$

1-5 Life Expectancy

1-5-1 Calculation Formula

The life(L) of a linear motion bearing can be obtained from the following equation with the basic dynamic load rating and the load applied to the bearing:

$$L = \left(\frac{f_H \cdot f_T \cdot f_C \cdot C}{f_w \cdot P} \right)^3 \cdot 50 \quad (1)$$

- L : Rated life(km)
- C : Basic dynamic load rating(N)
- P : Working load(N)
- f_w : Load coefficient
- f_H : Hardness factor
- f_T : Temperature coefficient
- f_C : Contact coefficient

The lifespan(L_h) of a linear motion bearing in hours can be obtained by calculating the traveling distance per unit time. The lifespan can be obtained from the following equation if the stroke length and the number of strokes are constant:

$$L_h = \left(\frac{L \cdot 10^3}{2 \cdot S \cdot n_i \cdot 60} \right) \quad (2)$$

- L_h : Lifespan(hr)
- L: Rated life(km)
- S: Stroke length(m)
- n_i : Number of strokes per minute(CPM)

Selecting the linear motion bearing type satisfying the following conditions:

- number of linear motion bearing used 4
- Stroke length.....1m
- number of strokes per minute 5(cpm)
- lifespan.....10000(hr)
- Total load.....980N

Assume the following with a pair of shafts each with two bearings. From equation, the basic dynamic load rating is obtained as follow:

1-5-2 Sample Calculations

Obtaining the rated life L and lifespan L_h of the LIMON linear motion bearing used in the following conditions:

- linear motion bearing.....Lm20
- stroke length.....50mm
- number of strokes per minute.....50(cpm)
- load per bearing.....490N

The basic dynamic load rating of the linear motion bearing is 882N from the dimension table. From equation, therefore the rated life L is obtained as follows :

$$L = \left(\frac{f_H \cdot f_T \cdot f_C \cdot C}{f_w \cdot P} \right)^3 \cdot 50 \quad F_H = f_T = f_C = f_w = 1.0$$

$$= \left(\frac{882}{490} \right)^3 \cdot 50 = 292 \text{ km}$$

$$L = 2 \times e_s \times n_i \times 60 \times L_h = 6,000 \text{ km}$$

$$C = \sqrt[3]{\frac{L}{50}} \cdot \left(\frac{f_w}{f_H \cdot f_T \cdot f_C} \right) \cdot P = 1492 \text{ N}$$

The lifespan L_h is obtained as follows:

$$L_h = \frac{L \cdot 10^3}{2 \times e_s \times n_i \times 60} = \frac{292 \times 10^3}{2 \times 0.05 \times 50 \times 60} = 973 \text{ hr}$$

As a result, LM30 is selected from the dimension table as the LIMON linear motion bearing type satisfying the value of C.

1-6 Mounting

When inserting the linear bearing into the housing, do not hit the linear bearing on the linear bearing ring holding the retainer but apply the cylinder circumference with a proper jig and push the linear bearing into the housing by hand or lightly knock it in. (See Fig. 1) In inserting the shaft after mounting the bearing, be careful not to shock the balls. Note that if two shafts are used in parallel, the parallelism is the most important factor to assure the smooth linear movement. Take care in setting the shafts.

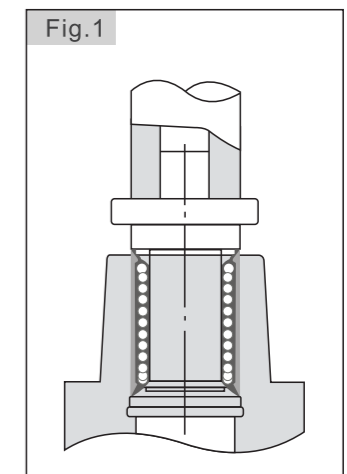

1-6-1 Examples Of Mounting

The popular way to mount a linear bearing is to operate it with an appropriate interference. It is recommended, however, to make a loose fit in principle because otherwise precision is apt to be minimized.

The following examples(Figs. 2 to 6)show assembling of the inserted bearing in terms of designing and mounting, for reference.

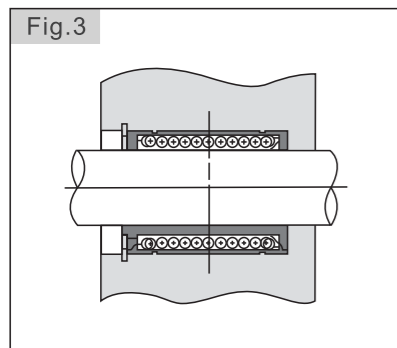
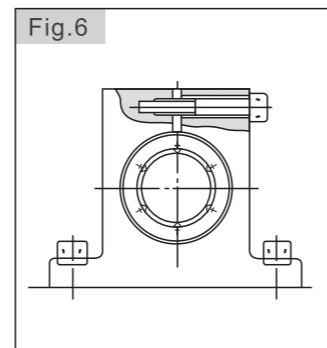
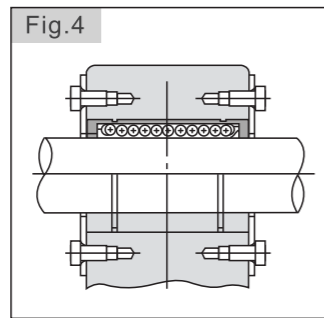
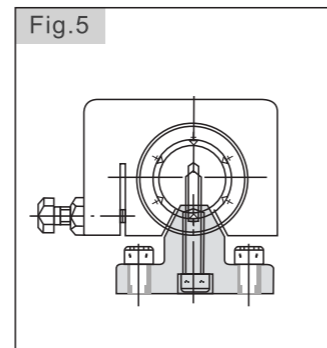
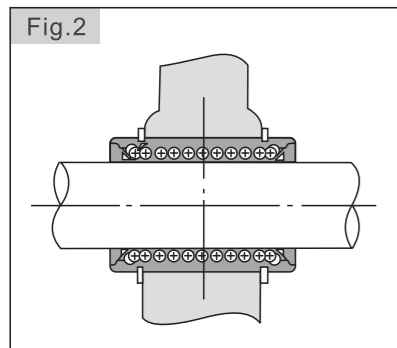

1-7 Lubrication and Dust Prevention

Using LIMON linear systems without lubrication increases the abrasion of the rolling elements, shortening the lifespan, the LIMON linear systems therefore require appropriate lubrication. For lubrication LIMON recommends turbine oil conforming to ISO Standards G32 to G68 or lithium base soap grease NO.2. Some LIMON linear systems are sealed to block dust out and seal lubricant in. If used in a harsh or corrosive environment, however apply a protective cover to the part involving linear motion.

2 Linear Motion Ball Bearing 2-1 KH Series



KH

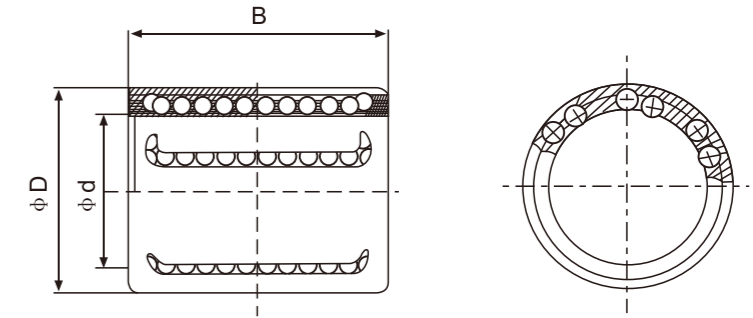

Part No.	Main Dimensions			Basic Load Rating		Weight (g)
	ϕd	ϕD	B	C N	C ₀ N	
KH-0622	6	12	22	400	239	7
KH-0824	8	15	24	435	280	12
KH-1026	10	17	26	500	370	14.5
KH-1228	12	19	28	620	510	18.5
KH-1428	14	21	28	620	520	20.5
KH-1630	16	24	30	800	620	27.5
KH-2030	20	28	30	950	790	32.5
KH-2540	25	35	40	1990	1670	66
KH-3050	30	40	50	2800	2700	95
KH-4060	40	52	60	4400	4450	182
KH-5070	50	62	70	5500	6300	252

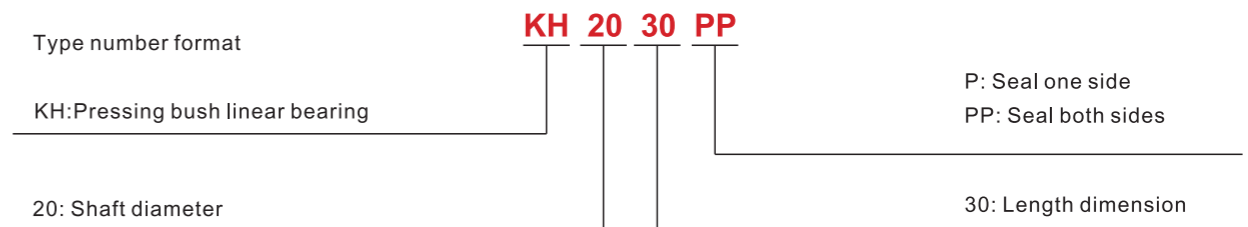

2-2 LM Series

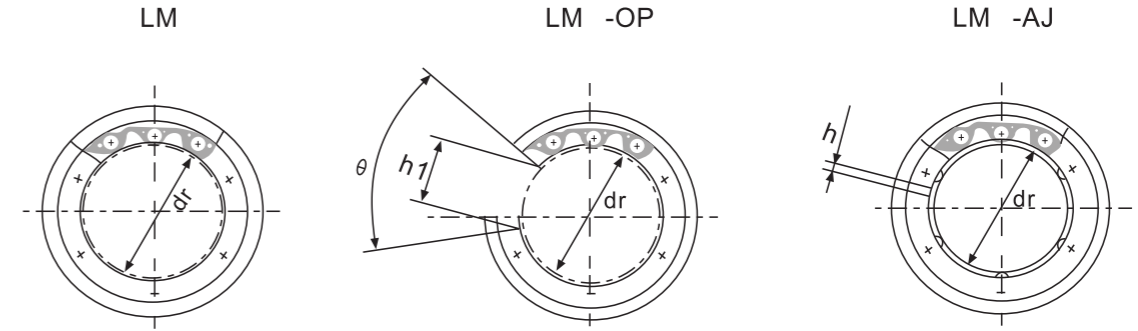
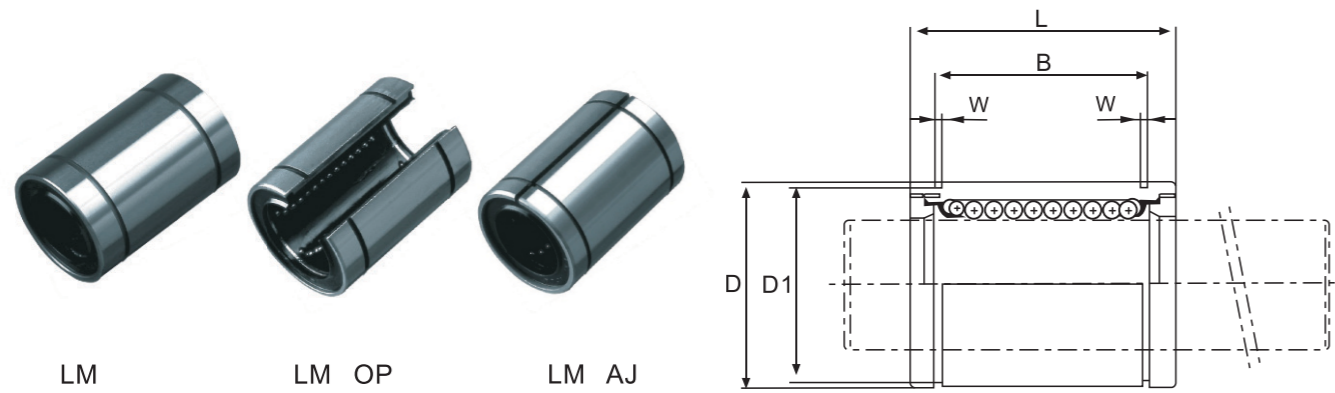

Part No.						Main Dimensions and Tolerance				
Seal Type	Ball Circuit	Open Type	Ball Circuit	Adjustable Type	Ball Circuit	dr (mm)	Tolerance (μm)	D (mm)	Tolerance (μm)	
LM4	4	-	-	-	-	4	0	8	0	
LM5UU	4	-	-	-	-	5	-8	10	-9	
LM6UU	4	-	-	LM6UUAJ	4	6	0	12	-11	
LM8SUU	4	-	-	LM8SUUAJ	4	8		15		
LM8UU	4	-	-	LM8UUAJ	4	8		15		
LM10UU	4	-	-	☆LM10UUAJ	4	10		19		
☆LM12UU	4	LM12UU-OP	3	☆LM12UUAJ	4	12	-9	21	0	
LM13UU	4	LM13UU-OP	3	LM13UUAJ	4	13		23		-13
☆LM16UU	5	LM16UU-OP	4	☆LM16UUAJ	5	16		28		
☆LM20UU	5	LM20UU-OP	4	☆LM20UUAJ	5	20	0	32	-10	
☆LM25UU	6	LM25UU-OP	5	☆LM25UUAJ	6	25		40		0
☆LM30UU	6	LM30UU-OP	5	☆LM30UUAJ	6	30	-10	45	-16	
LM35UU	6	LM35UU-OP	5	LM35UUAJ	6	35		52		0
☆LM40UU	6	LM40UU-OP	5	☆LM40UUAJ	6	40	0	60	-19	
LM50UU	6	LM50UU-OP	5	LM50UUAJ	6	50		80		0
LM60UU	6	LM60UU-OP	5	LM60UUAJ	6	60	0/-15	90	-22	

Note : ☆ means steel retainer is available.

Main Dimensions and Tolerance									Eccentricity (max) μm	Radial Clearance (max) μm	Basic Load Rating		Weight (g)
L (mm)	Tolerance (μm)	B (mm)	Tolerance (μm)	W (mm)	D1 (mm)	h (mm)	h1 (mm)	θ			C N	Co N	
12	0	-	0	-	-	-	-	-	8	-3	88	127	2
15		-120		10.2	1.1	9.6	-	-			-	167	206
19	0	13.5	-200	1.1	11.5	1.0	-	-	12	-4	206	265	8.5
17		11.5		1.1	14.3	1.0	-	-			176	216	11
24		17.5		1.1	14.3	1.0	-	-			274	392	17
29		22		1.3	18	1.0	-	-			372	549	36
30		23		1.3	20	1.5	8	80°			412	598	42
32		23		1.3	22	1.5	9	80°			510	784	49
37	26.5	1.6	27	1.5	11	80°	774	1180	76				
42	30.5	1.6	30.5	1.5	11	60°	882	1370	100				
59	0	41	0	1.85	38	2	12	50°	15	-6	980	1570	240
64		44.5		1.85	43	2.5	15	50°			1570	2740	270
70		49.5		2.1	49	2.5	17	50°			1670	3140	425
80		60.5		2.1	57	3	20	50°			2160	4020	654
100		74		2.6	76.5	3	25	50°			3820	7940	1700
110	85	3.15	86.5	3	30	50°	4700	10000	2000				

2-2 LME Series

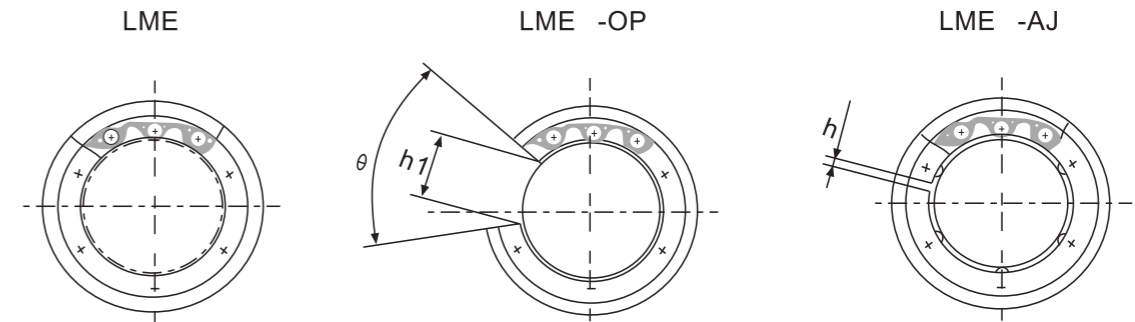
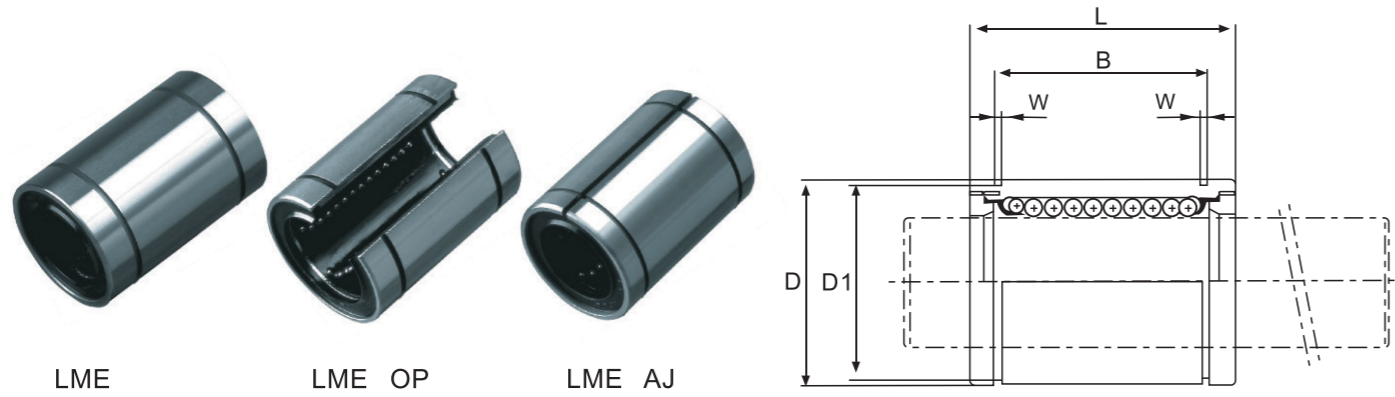

Part No.					Main Dimensions and Tolerance			
Seal Type	Ball Circuit	Open Type	Ball Circuit	Adjustable Type	Ball Circuit	dr (mm)	Tolerance (μm)	D (mm)
LME5UU	4	-	-	LME5UUAJ	4	5	+8 0	12
LME8UU	4	-	-	LME8UUAJ	4	8		16
☆ LME12UU	4	LME12UU-OP	3	☆ LME12UUAJ	4	12	+9 -1	22
☆ LME16UU	5	LME16UU-OP	4	☆ LME16UUAJ	5	16		26
☆ LME20UU	5	LME20UU-OP	4	☆ LME20UUAJ	5	20	+11 -1	32
☆ LME25UU	6	LME25UU-OP	5	☆ LME25UUAJ	6	25		40
☆ LME30UU	6	LME30UU-OP	5	☆ LME30UUAJ	6	30	+13 -2	47
☆ LME40UU	6	LME40UU-OP	5	☆ LME40UUAJ	6	40		62
LME50UU	6	LME50UU-OP	5	LME50UUAJ	6	50	+13 -2	75
LME60UU	6	LME60UU-OP	5	LME60UUAJ	6	60		90

Note : ☆ means steel retainer is available.

Main Dimensions and Tolerance										Eccentricity (max) μm	Radial Clearance (max) μm	Basic Load Rating		Weight (g)
Tolerance (μm)	L (mm)	Tolerance (μm)	B (mm)	Tolerance (μm)	W (mm)	D1 (mm)	h (mm)	h1 (mm)	θ			C N	Co N	
0 -8	22	0 -200	14.5	0 -300	1.1	11.5	1	-	-	12	-3	206	265	11
	25		16.5		1.1	15.2	1	-	-			265	402	22
0 -9	32	0 -200	22.9	0 -300	1.3	21	1.5	7.5	78°	12	-4	510	784	45
	36		24.9		1.3	24.9	1.5	10	78°			775	1180	60
0 -11	45	0 -300	31.5	0 -400	1.6	30.3	2	10	60°	15	-6	862	1370	102
	58		44.1		1.85	37.5	2	12.5	60°			980	1570	235
0 -13	68	0 -300	52.1	0 -400	1.85	44.5	2	12.5	50°	17	-8	1570	2740	360
	80		60.6		2.15	59	3	16.8	50°			2160	4020	770
0/-15	100	0/-400	77.6	0/-400	2.65	72	3	21	50°	20	-13	3820	7940	1250
0/-15	125		101.7		3.15	86.5	3	27.2	54°			4700	9800	2220

2-3 LML Series

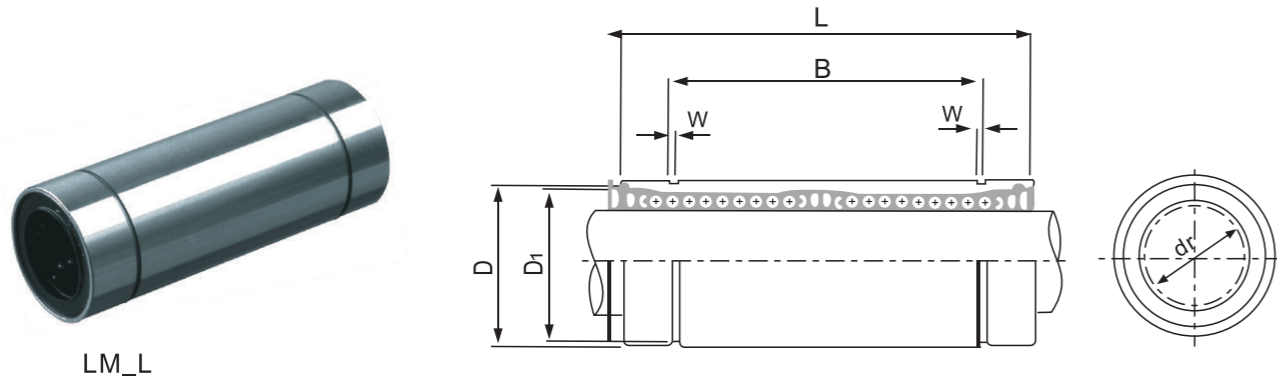

2-4 LMEL Series

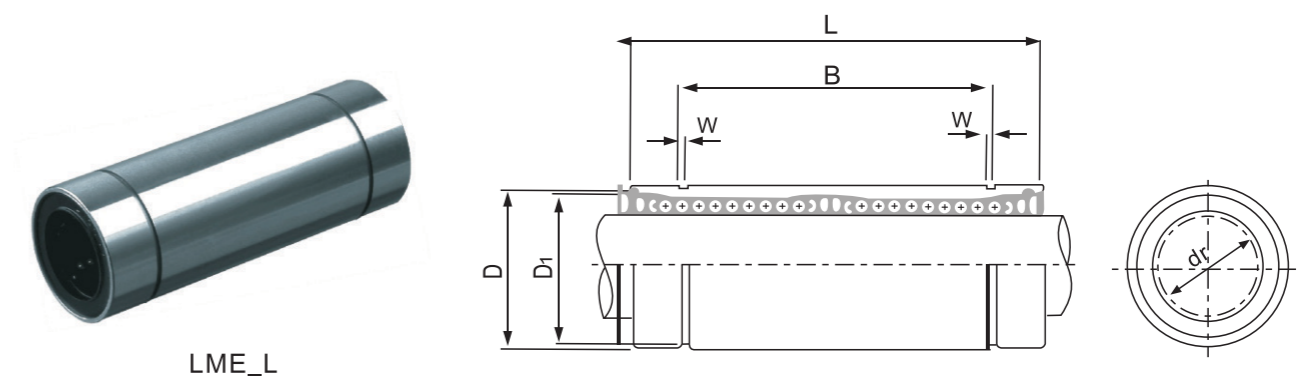

Linear Guideways

Ball Screw

Support

Linear Bushing

Linear Guideways

Ball Screw

Support

Linear Bushing

Part No.		Main Dimensions and Tolerance										Basic Load Rating		Eccentricity	Weight (g)							
Seal Type	Ball Circuit	dr (mm)	Tolerance (μm)	D (mm)	Tolerance (μm)	L (mm)	Tolerance (μm)	B (mm)	Tolerance (μm)	W (mm)	D1 (mm)	C N	Co N									
	LM6LUU	4	6	0 -10	12	0 -13	35	0 -300	0 -400	27	1.1	11.5	323	530	15	16						
	LM8LUU	4	8		15		45										35	1.1	14.3	431	784	31
☆	LM10LUU	4	10		19		55										44	1.3	18	588	1100	62
☆	LM12LUU	4	12		21		57										46	1.3	20	813	1570	80
	LM13LUU	4	13		23		61										46	1.3	22	813	1570	90
☆	LM16LUU	5	16	0 -12	28	0 -16	70	0 -300	0 -400	53	1.6	27	1230	2350	20	145						
☆	LM20LUU	5	20		32		80										61	1.6	30.5	1400	2740	180
☆	LM25LUU	6	25		40		112										82	1.85	38	1560	3140	440
☆	LM30LUU	6	30		45		123										89	1.85	43	2490	5490	580
	LM35LUU	6	35		52		135										99	2.1	49	2650	6270	795
☆	LM40LUU	6	40	0 -15	60	0 -19	151	0 -400	0 -500	121	2.1	57	3430	8040	25	1170						
	LM50LUU	6	50		80		192										148	2.6	76.5	6080	15900	3100
	LM60LUU	6	60		0/-20		90										0/-25	209	3.15	86.5	7550	20000

Note : ☆ means steel retainer is available.

Part No.		Main Dimensions and Tolerance										Eccentricity	Basic Load Rating		Weight (g)								
Seal Type	Ball Circuit	dr (mm)	Tolerance (μm)	D (mm)	Tolerance (μm)	L (mm)	Tolerance (μm)	B (mm)	Tolerance (μm)	W (mm)	D1 (mm)		C N	Co N									
	LME8LUU	4	8	+9 -1	16	0/-9	46	0	-300	33	1.1	15.2	15	421	804	40							
☆	LME12LUU	4	12		22		61										45.8	21	813	1570	80		
☆	LME16LUU	5	16	+11 -1	26	0	-11	68	-400	49.8	1.3	24.9	15	921	1780	115							
☆	LME20LUU	5	20		32												80	61	1.6	30.5	1370	2740	180
☆	LME25LUU	6	25	+13 -2	40	0	-13	112	0	82	1.85	38	17	1570	3140	430							
☆	LME30LUU	6	30		47												123	104.2	1.85	44.5	2500	5490	615
☆	LME40LUU	6	40	+16 -4	62	0	-15	151	0	121.2	2.15	59	20	3430	8040	1400							
	LME50LUU	6	50		75												192	155.2	2.65	72	6080	15900	2320
	LME60LUU	6	60		90												0/-20	209	170	3.15	86.5	7550	20000

Note : ☆ means steel retainer is available.

3 Flanged Linear Motion Ball Bearing 3-1 LMF/K/H Series

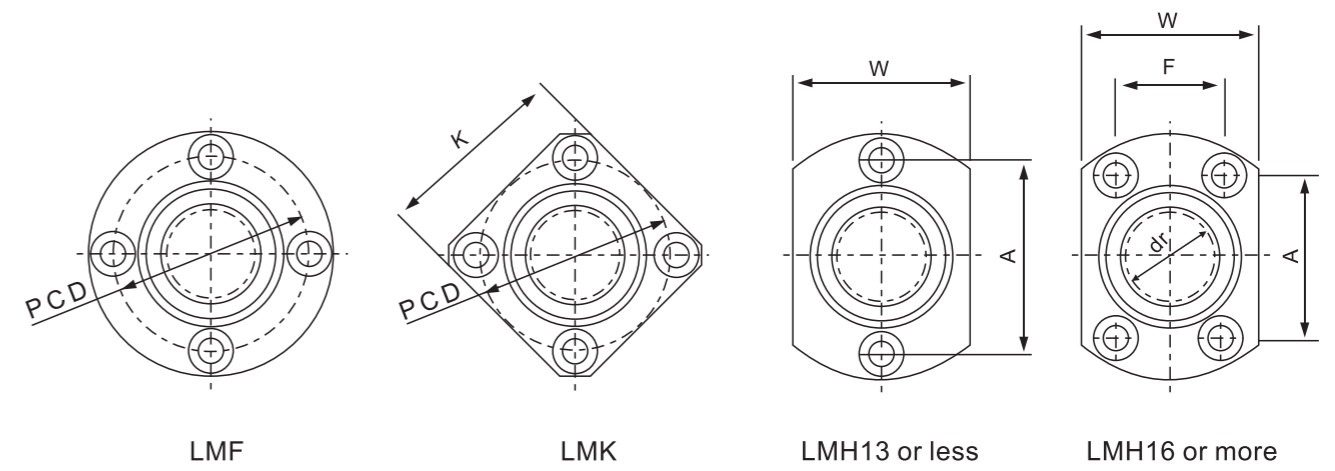
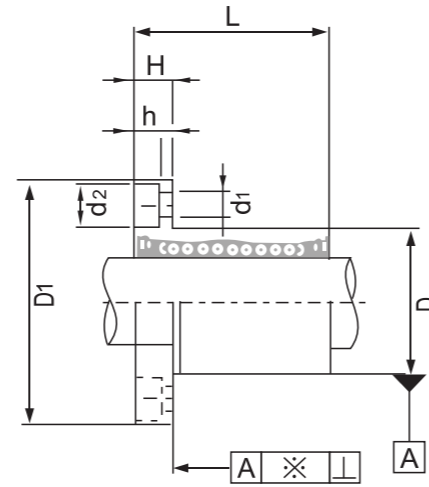

Part No.			Main Dimensions and Tolerance												
Seal Type	Ball Circuit	dr (mm)	Tolerance (μm)	D (mm)	Tolerance (μm)	L (mm)	Tolerance (μm)	D1 (mm)	H (mm)	PCD (mm)	K (mm)	W (mm)	A (mm)		
LMF6UU	LMK6UU	LMH6UU	4	6	0 -9	12	19	±300	28	5	20	22	18	20	
LMF8UU	LMK8UU	LMH8UU	4	8		15	24		32	5	24	25	21	24	
☆LMF10UU	☆LMK10UU	☆LMH10UU	4	10		19	29		40	6	29	30	25	29	
☆LMF12UU	☆LMK12UU	☆LMH12UU	4	12	0 -13	21	30	-200	42	6	32	32	27	32	
LMF13UU	LMK13UU	LMH13UU	4	13		23	32		43	6	33	34	29	33	
☆LMF16UU	☆LMK16UU	☆LMH16UU	5	16		28	37		48	6	38	37	34	31	
☆LMF20UU	☆LMK20UU	☆LMH20UU	5	20	0 -16	32	42	-300	54	8	43	42	38	36	
☆LMF25UU	☆LMK25UU	☆LMH25UU	6	25		40	59		62	8	51	50	46	40	
☆LMF30UU	☆LMK30UU	☆LMH30UU	6	30		45	64		74	10	60	58	51	49	
LMF35UU	LMK35UU	LMK35UU	6	35	0 -19	52	70	-400	82	10	67	64	60	55	
☆LMF40UU	☆LMK40UU	LMK40UU	6	40		60	80		96	13	78	75	70	64	
LMF50UU	LMK50UU	-	6	50		80	100		116	13	98	92	-	-	
LMF60UU	LMK60UU	-	6	60	0/-15	90	0/-22	110	-400	134	18	112	106	-	

Note : ☆ means steel retainer is available.

F (mm)	d1xd2xh (mm)	Eccentricity (max) μm	Radial Clearance (max) μm	Basic Load Rating		Weight (g)
				C N	Co N	
-	3.5x6x3.1	12	-3	206	265	24
-	3.5x6x3.1			274	392	37
-	4.5x7.5x4.1			372	549	72
-	4.5x7.5x4.1	15	-4	510	784	76
-	4.5x7.5x4.1			510	784	88
22	4.5x7.5x4.1			774	1180	120
24	5.5x9x5.1	20	-6	882	1370	180
32	5.5x9x5.1			980	1570	340
35	6.6x11x6.1			1570	2740	470
38	6.6x11x6.1	25	-8	1670	3140	650
45	9x14x8.1			2160	4020	1060
-	9x14x8.1			3820	7940	2200
-	11x17x11.1	-13	-10	4700	10000	3000
-	11x17x11.1			4700	10000	3000

3-2 LMEF/K/H Series



LMEF



LMEK

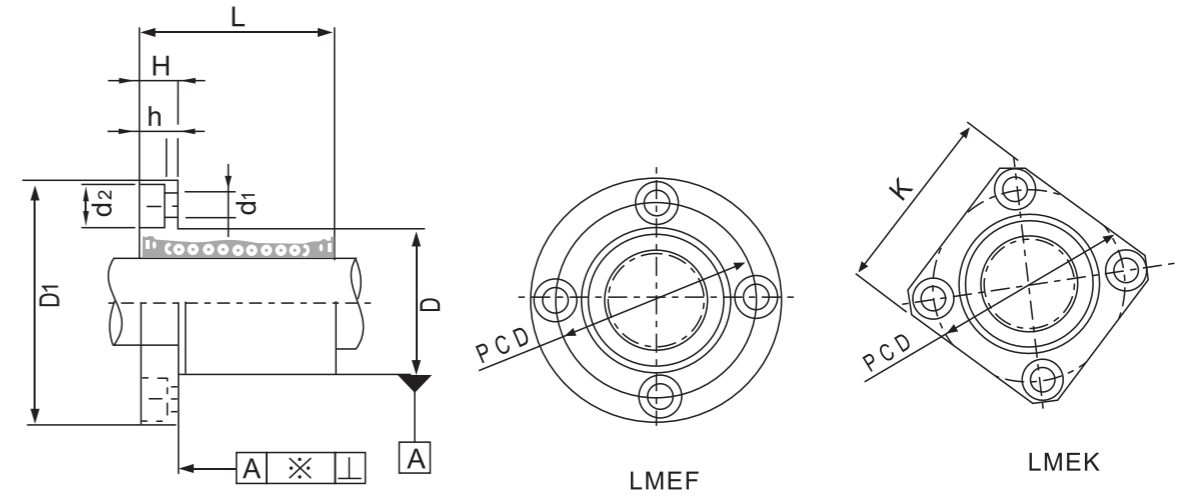

Part No.			Main Dimensions and Tolerance							
Seal Type	Ball Circuit		dr (mm)	Tolerance (μm)	D (mm)	Tolerance (μm)	L (mm)	Tolerance (μm)	D1 (mm)	
LMEF8UU	LMEK8UU	LMEH8UU	4	8	16	0/-11	25	±300	32	
☆ LMEF12UU	☆ LMEK12UU	☆ LMEH12UU	4	12						22
☆ LMEF16UU	☆ LMEK16UU	☆ LMEH16UU	5	16	26	-13	36	-200	46	
☆ LMEF20UU	☆ LMEK20UU	☆ LMEH20UU	5	20	32	0	45	-300	54	
☆ LMEF25UU	☆ LMEK25UU	☆ LMEH25UU	6	25	40		-16		58	62
☆ LMEF30UU	☆ LMEK30UU	☆ LMEH30UU	6	30	47	0	68	-300	76	
☆ LMEF40UU	☆ LMEK40UU	☆ LMEH40UU	6	40	62		-19		80	98
LMEF50UU	LMEK50UU	LMEH50UU	6	50	75	+13 -2	100	-400	112	
LMEF60UU	LMEK60UU	LMEH60UU	6	60	90		0/-22		125	134

Note : ☆ means steel retainer is available.

Main Dimensions and Tolerance				Eccentricity (max) μm	Radial Clearance (max) μm	Basic Load Rating		Weight (g)
H (mm)	PCD (mm)	K (mm)	d1xd2xh (mm)			C N	Co N	
5	24	25	3.5x6x3.1	12	-3	265	402	41
6	32	32	4.5x7.5x4.1		-4	510	784	80
6	36	35	4.5x7.5x4.1	15		-6	578	892
8	43	42	5.5x9x5.1		862		1370	182
8	51	50	5.5x9x5.1		980	1570	335	
10	62	60	6.6x11x6.1	20	-8	1570	2740	560
13	80	75	9x14x8.1			2160	4020	1175
13	94	88	9x14x8.1	25	-13	3820	7940	1745
18	112	106	11x17x11.1			4700	9800	3220

3-3 LMF/K/H_L Series

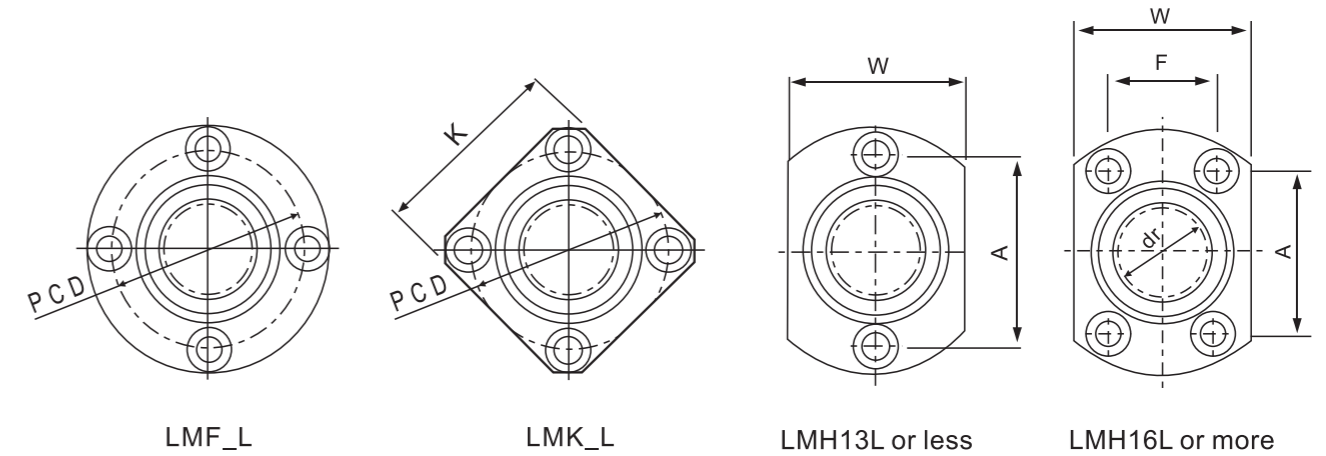
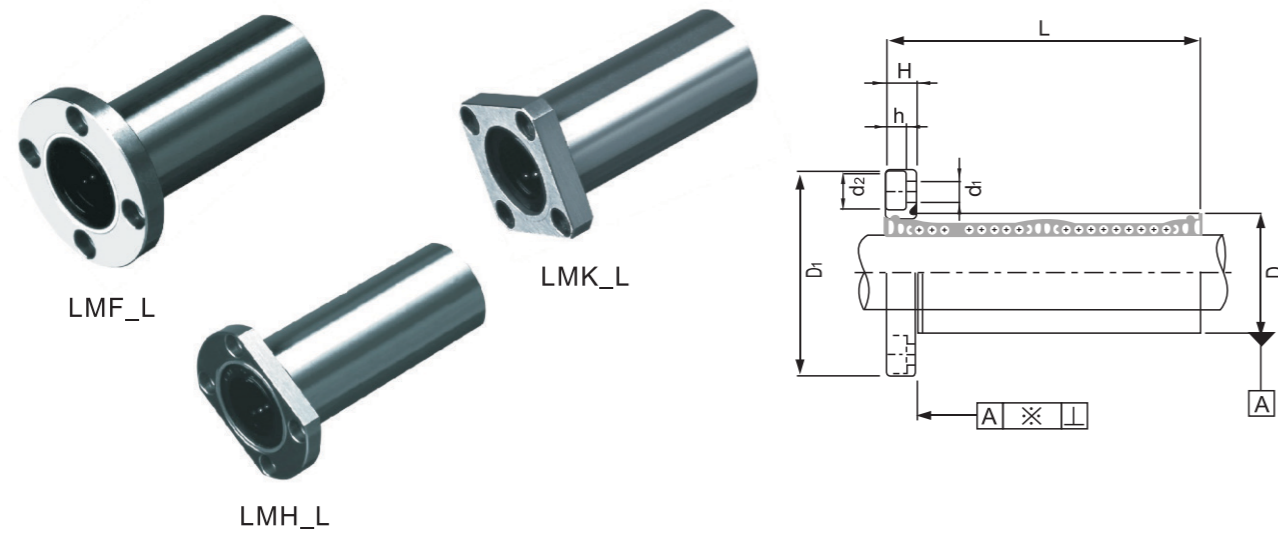

Linear Guideways

Ball Screw

Support

Linear Bushing

Linear Guideways

Ball Screw

Support

Linear Bushing

Part No.			Main Dimensions and Tolerance							
Seal Type	Ball Circuit	dr (mm)	Tolerance (μm)	D (mm)	Tolerance (μm)	L (mm)	Tolerance (μm)	D1 (mm)	H (mm)	
LMF6LUU	LMK6LUU	LMH6LUU	4	6	0 -13	12	35	±300	28	5
LMF8LUU	LMK8LUU	LMH8LUU	4	8		15	45		32	5
☆ LMF10LUU	☆ LMK10LUU	☆ LMH10LUU	4	10		19	55		40	6
☆ LMF12LUU	☆ LMK12LUU	☆ LMH12LUU	4	12	0 -16	21	57	-300	42	6
LMF13LUU	LMK13LUU	☆ LMH13LUU	4	13		23	61		43	6
☆ LMF16LUU	☆ LMK16LUU	☆ LMH16LUU	5	16		28	70		48	6
☆ LMF20LUU	☆ LMK20LUU	☆ LMH20LUU	5	20	0 -12	32	80	-400	54	8
☆ LMF25LUU	☆ LMK25LUU	☆ LMH25LUU	6	25		40	112		62	8
☆ LMF30LUU	☆ LMK30LUU	☆ LMH30LUU	6	30		45	123		74	10
LMF35LUU	LMK35LUU	LMH35LUU	6	35	0 -15	52	135	-400	82	10
☆ LMF40LUU	LMK40LUU	-	6	40		60	151		96	13
LMF50LUU	LMK50LUU	-	6	50		80	192		116	13
LMF60LUU	LMK60LUU	-	6	60	0/-20	90	0/-25	209	134	18

Note : ☆ means steel retainer is available.

Main Dimensions and Tolerance						Eccentricity (max) μm	Radial Clearance (max) μm	Basic Load Rating		Weight (g)
PCD (mm)	K (mm)	W (mm)	A (mm)	F (mm)	d1xd2xh (mm)			C N	Co N	
20	22	18	20	-	3.5x6x3.1	15	-3	323	529	31
24	25	21	24	-	3.5x6x3.1		-3	431	784	51
29	30	25	29	-	4.5x7.5x4.1		-4	588	1100	98
32	32	27	32	-	4.5x7.5x4.1		-4	813	1570	110
33	34	29	33	-	4.5x7.5x4.1		-4	813	1570	130
38	37	34	31	22	4.5x7.5x4.1		-6	1230	2350	190
43	42	38	36	24	5.5x9x5.1	20	-6	1400	2740	260
51	50	46	40	32	5.5x9x5.1		-6	1560	3140	540
60	58	51	49	35	6.6x11x6.1		-8	2490	5490	680
67	64	60	55	38	6.6x11x6.1	25	-8	2650	6270	1020
78	75	-	-	-	9x14x8.1		-10	3430	8040	1570
98	92	-	-	-	9x14x8.1		-13	6080	15900	3600
112	106	-	-	-	11x17x11.1		-13	7550	20000	4500

3-4 LMEF/K_L Series

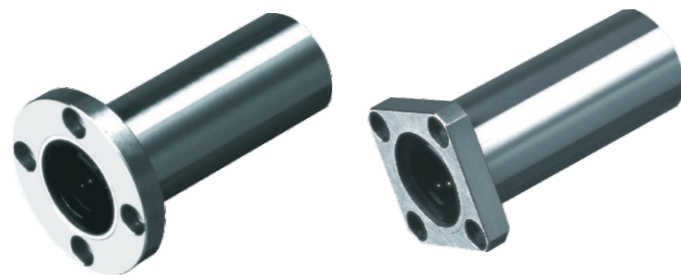

LMEF_L

LMEK_L

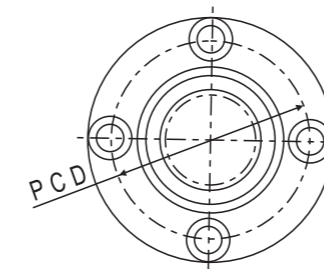
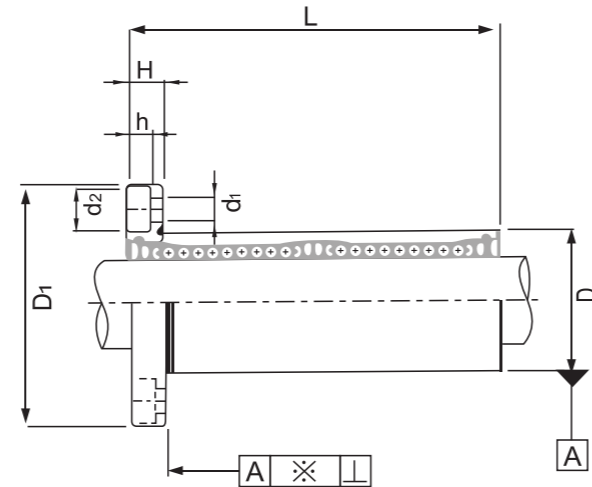

LMEF_L

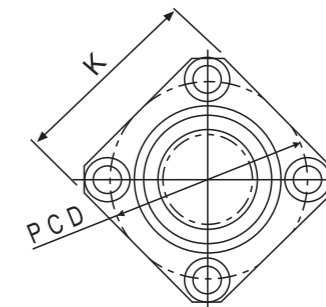

LMEK_L

Part No.		Main Dimensions and Tolerance								
Seal Type	Ball Circuit	dr (mm)	Tolerance (μm)	D (mm)	Tolerance (μm)	L (mm)	Tolerance (μm)	D1 (mm)	H (mm)	
LMEF8LUU	LMEK8LUU	4	8	+9 -1	16	0/-13	46	±300	32	5
☆ LMEF12LUU	☆ LMEK12LUU	4	12	+11 -1	22	0 -16	61	-300	42	6
☆ LMEF16LUU	☆ LMEK16LUU	5	16		26	68	46		6	
☆ LMEF20LUU	☆ LMEK20LUU	5	20	+13 -2	32	0 -19	80	-400	54	8
☆ LMEF25LUU	☆ LMEK25LUU	6	25		40	112	62		8	
☆ LMEF30LUU	☆ LMEK30LUU	6	30	+16 -4	47	0 -22	123	-400	76	10
☆ LMEF40LUU	☆ LMEK40LUU	6	40		62	151	98		13	
LMEF50LUU	LMEK50LUU	6	50	+16 -4	75	0 -22	192	-400	112	13
LMEF60LUU	LMEK60LUU	6	60		90	209	134		18	

Note : ☆ means steel retainer is available.

Main Dimensions and Tolerance			Eccentricity (max) μm	Radial Clearance (max) μm	Basic Load Rating		Weight (g)
PCD (mm)	K (mm)	d1xd2xh (mm)			C N	Co N	
24	25	3.5x6x3.1	12	-3	365	402	41
32	32	4.5x7.5x4.1		-4	510	784	80
36	35	4.5x7.5x4.1			578	892	103
43	42	5.5x9x5.1	15	-6	862	1370	182
51	50	5.5x9x5.1			980	1570	335
62	60	6.6x11x6.1			-8	1570	2740
80	75	9x14x8.1	20	2160		4020	1175
94	88	9x14x8.1		-13	3820	7940	1745
112	106	11x17x11.1	4700		9800	3220	

3-5 LMF/K/HP Series

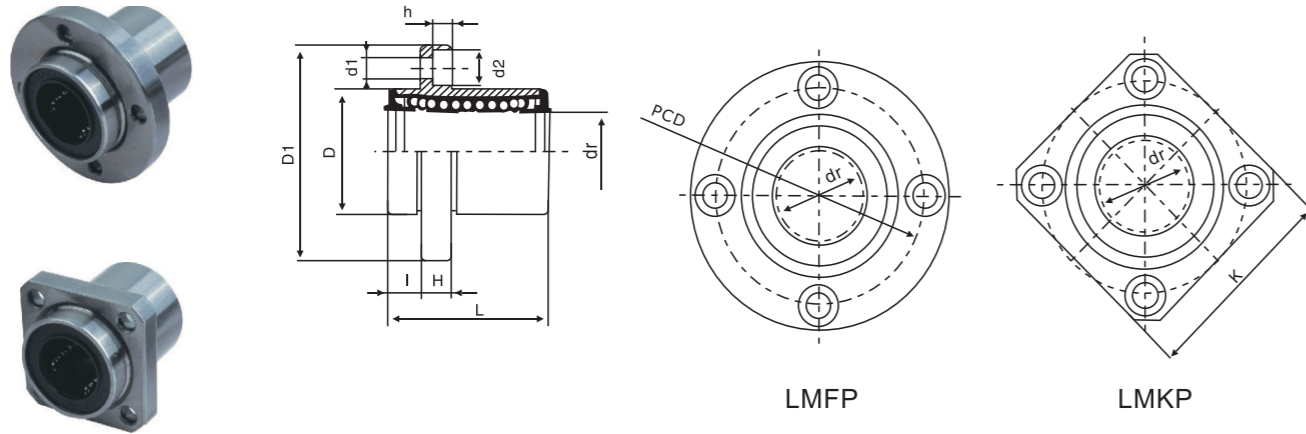

LMFP

LMKP

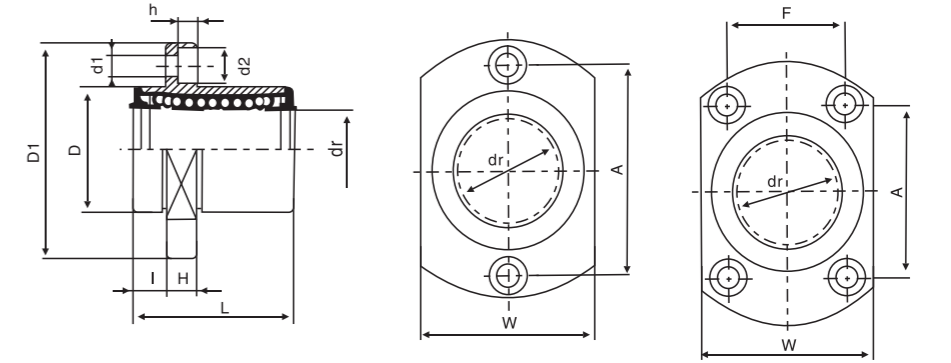

LMHP6~LMHP13

LMHP16~LMHP30

Part No.		Main Dimensions and Tolerance													Eccentricity	Basic Load Rating		Weight (g)
Seal Type	Ball Circuit	dr (mm)	Tolerance (μm)	D (mm)	Tolerance (μm)	L (mm)	Tolerance (μm)	I (mm)	D1 (mm)	K (mm)	H (mm)	PCD (mm)	d1xd2xh (mm)	C		Co	N	
LMFP6UU	LMKP6UU	4	6		12	0	19		5	28	22	5	20	3.5x6x3.1	206	265	24	
LMFP8UU	LMKP8UU	4	8		15	0	24	±300	5	32	25	5	24	3.5x6x3.1	274	392	37	
☆LMFP10UU	☆LMKP10UU	4	10	0	19		29		6	40	30	6	29	4.5x7.5x4.1	372	549	72	
☆LMFP12UU	☆LMKP12UU	4	12	0	21	0	30	-200	6	42	32	6	32	4.5x7.5x4.1	510	784	76	
LMFP13UU	LMKP13UU	4	13		23	0	32		6	43	34	6	33	4.5x7.5x4.1	510	784	88	
☆LMFP16UU	☆LMKP16UU	5	16		28		37		6	48	37	6	38	4.5x7.5x4.1	774	1180	120	
☆LMFP20UU	☆LMKP20UU	5	20		32		42		8	54	42	8	43	5.5x9x5.1	882	1370	180	
☆LMFP25UU	☆LMKP25UU	6	25	0	40	0	59		8	62	50	8	51	5.5x9x5.1	980	1570	340	
☆LMFP30UU	☆LMKP30UU	6	30		45		64	-300	10	74	58	10	60	6.6x11x6.1	1570	2740	470	
LMFP35UU	LMKP35UU	6	35		52		70		10	82	64	10	67	6.6x11x6.1	1670	3140	650	
☆LMFP40UU	☆LMKP40UU	6	40	0	60	0	80		13	96	75	13	78	9x14x8.1	2160	4020	1060	
LMFP50UU	LMKP50UU	6	50		80		100		13	116	92	13	98	9x14x8.1	3820	7940	2200	
LMFP60UU	LMKP60UU	6	60	0	90	0	110	-400	18	134	106	18	122	11x17x11.1	4700	10000	3000	

Note : ☆ means steel retainer is available.

Part No.		Main Dimensions and Tolerance															Eccentricity	Basic Load Rating		Weight (g)
Seal Type	Ball Circuit	dr (mm)	Tolerance (μm)	D (mm)	Tolerance (μm)	L (mm)	Tolerance (μm)	I (mm)	D1 (mm)	W (mm)	H (mm)	A (mm)	F (mm)	D1xd2xh (mm)	C	Co		N	N	
LMHP6UU	4	6		12	0	19		5	28	18	5	20	-	3.5x6x3.1	206	265	21			
LMHP8UU	4	8		15	0	24	±300	5	32	21	5	24	-	3.5x6x3.1	274	392	33			
☆LMHP10UU	4	10	0	19		29		6	40	25	6	29	-	4.5x7.5x4.1	372	549	64			
☆LMHP12UU	4	12	0	21	0	30	-200	6	42	27	6	32	-	4.5x7.5x4.1	510	784	68			
LMHP13UU	4	13		23	0	32		6	43	29	6	33	-	4.5x7.5x4.1	510	784	81			
☆LMHP16UU	5	16		28		37		6	48	34	6	31	22	4.5x7.5x4.1	774	1180	112			
☆LMHP20UU	5	20		32		42		8	54	38	8	36	24	5.5x9x5.1	882	1370	167			
☆LMHP25UU	6	25	0	40	0	59	-300	8	62	46	8	40	32	5.5x9x5.1	980	1570	325			
☆LMHP30UU	6	30		45		64		10	74	51	10	49	35	6.6x11x6.1	1570	2740	388			

Note : ☆ means steel retainer is available.

3-6 LMF/K/HP_L Series

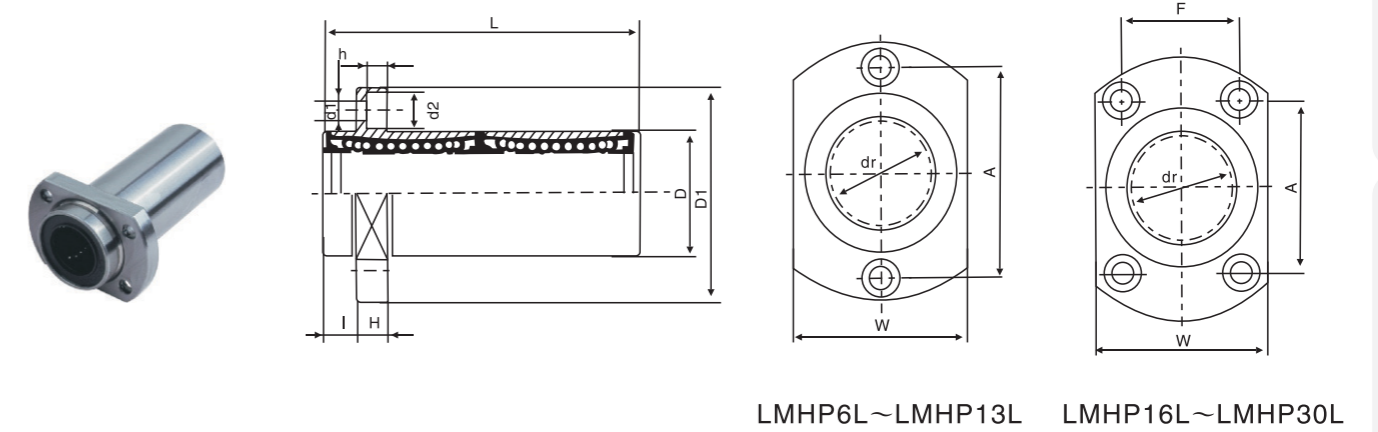
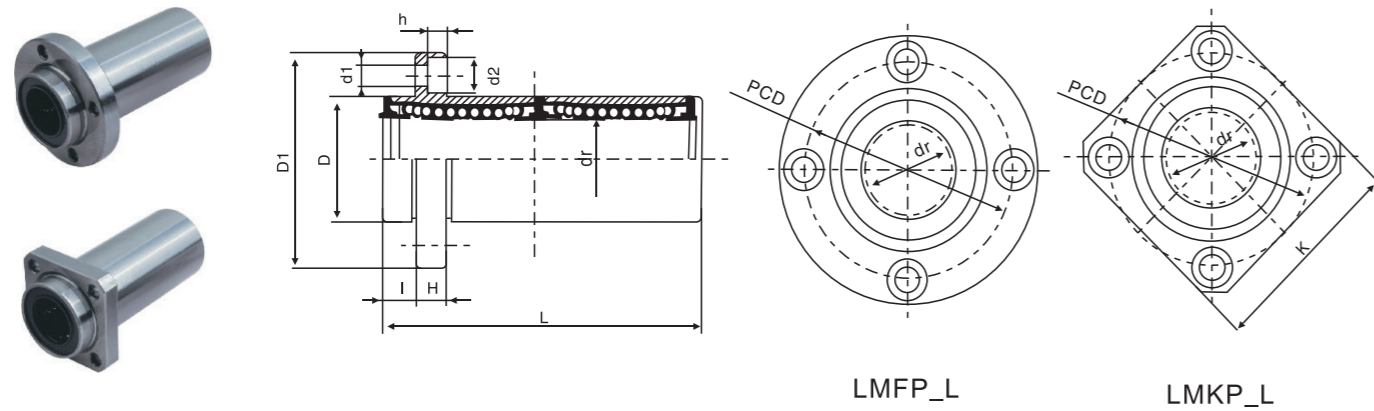

LMFP_L

LMKP_L

LMHP6L~LMHP13L LMHP16L~LMHP30L

Part No.		Main Dimensions and Tolerance												Eccentricity	Basic Load Rating		Weight (g)	
Seal Type	Ball Circuit	dr (mm)	Tolerance (μm)	D (mm)	Tolerance (μm)	L (mm)	Tolerance (μm)	I (mm)	D1 (mm)	K (mm)	H (mm)	PCD (mm)	d1xd2xh (mm)		C N	Co N		
LMFP6LUU	LMKP6LUU	4	6	0	12	-13	35	±300	5	28	22	5	20	3.5x6x3.1	15	323	529	31
LMFP8LUU	LMKP8LUU	4	8		15				45	5	32	25	5	24		3.5x6x3.1	431	784
☆LMFP10LUU	☆LMKP10LUU	4	10	0	19	-10	55	-200	6	40	30	6	29	4.5x7.5x4.1	20	588	1100	98
☆LMFP12LUU	☆LMKP12LUU	4	12		21				57	6	42	32	6	32		4.5x7.5x4.1	813	1570
LMFP13LUU	LMKP13LUU	4	13	0	23	-16	61	-300	6	43	34	6	33	4.5x7.5x4.1	25	813	1570	130
☆LMFP16LUU	☆LMKP16LUU	5	16		28				70	6	48	37	6	38		4.5x7.5x4.1	1230	2350
☆LMFP20LUU	☆LMKP20LUU	5	20	0	32	-19	80	-300	8	54	42	8	43	5.5x9x5.1	20	1400	2740	260
☆LMFP25LUU	☆LMKP25LUU	6	25		40				112	8	62	50	8	51		5.5x9x5.1	1560	3140
☆LMFP30LUU	☆LMKP30LUU	6	30	0	45	-22	123	-300	10	74	58	10	60	6.6x11x6.1	25	2490	5490	680
LMFP35LUU	LMKP35LUU	6	35		52				135	10	82	64	10	67		6.6x11x6.1	2650	6270
☆LMFP40LUU	☆LMKP40LUU	6	40	0	60	-25	151	-300	13	96	75	13	78	9x14x8.1	25	3430	8040	1570
LMFP50LUU	LMKP50LUU	6	50		80				192	13	116	92	13	98		9x14x8.1	6080	15900
LMFP60LUU	LMKP60LUU	6	60	0	90	-20	209	-400	18	134	106	18	112	11x17.5x10.8	7550	20000	4500	

Note : ☆ means steel retainer is available.

Part No.		Main Dimensions and Tolerance														Eccentricity	Basic Load Rating		Weight (g)
Seal Type	Ball Circuit	dr (mm)	Tolerance (μm)	D (mm)	Tolerance (μm)	L (mm)	Tolerance (μm)	I (mm)	D1 (mm)	W (mm)	H (mm)	A (mm)	F (mm)	d1xd2xh (mm)	C N		Co N		
LMHP6LUU	4	6	0	12	-13	35	±300	5	28	18	5	20	-	3.5x6x3.1	15	323	529	28	
LMHP8LUU	4	8		15				45	5	32	21	5	24	-		3.5x6x3.1	431	784	47
☆LMHP10LUU	4	10	0	19	-10	55	-200	6	40	25	6	29	-	4.5x7.5x4.1	20	588	1100	90	
☆LMHP12LUU	4	12		21				58	6	42	27	6	32	-		4.5x7.5x4.1	813	1570	102
☆LMHP13LUU	4	13	0	23	-16	61	-300	6	43	29	6	33	-	4.5x7.5x4.1	25	813	1570	123	
☆LMHP16LUU	5	16		28				70	6	48	34	6	31	22		4.5x7.5x4.1	1230	2350	182
☆LMHP20LUU	5	20	0	32	-19	80	-300	8	54	38	8	36	24	5.5x9x5.1	20	1400	2740	247	
☆LMHP25LUU	6	25		40				112	8	62	46	8	40	32		5.5x9x5.1	1560	3140	525
☆LMHP30LUU	6	30	0	45	-22	123	-300	10	74	51	10	49	35	6.6x11x6.1	25	2490	5490	645	

Note : ☆ means steel retainer is available.

3-7 LMF/KC Series

3-8 LMHC Series

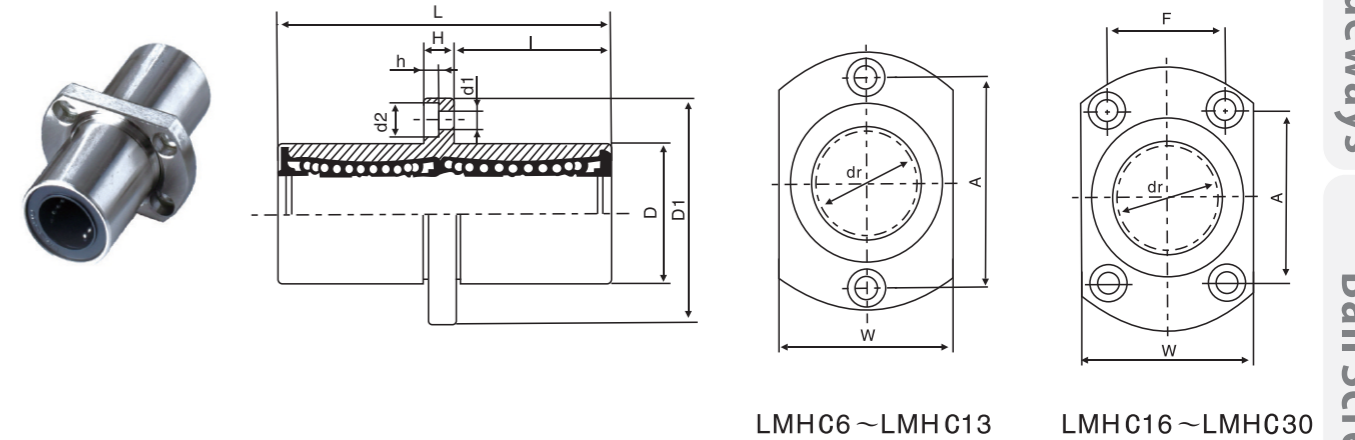
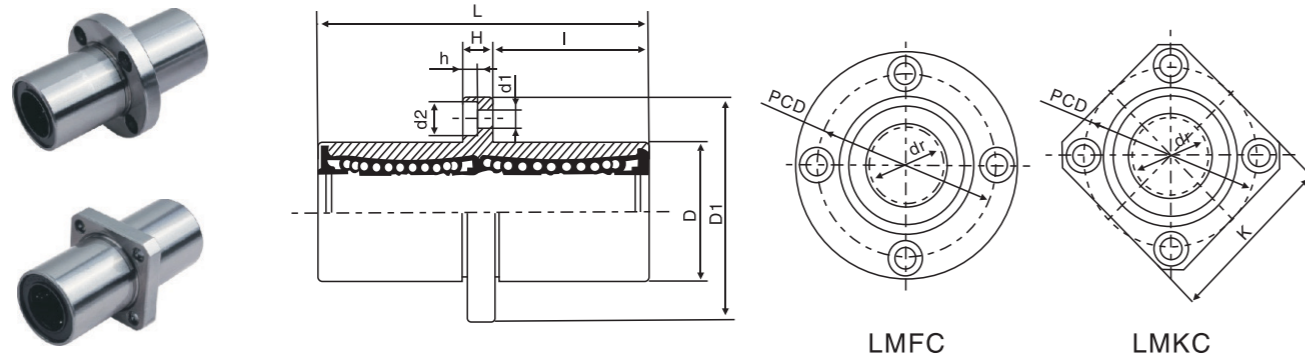

LMFC

LMKC

LMHC6~LMHC13

LMHC16~LMHC30

Part No.		Main Dimensions and Tolerance											Eccentricity	Basic Load Rating		Weight (g)
Seal Type	Ball Circuit	dr (mm)	Tolerance (μm)	D (mm)	Tolerance (μm)	L (mm)	Tolerance (μm)	I (mm)	D1 (mm)	K (mm)	H (mm)	PCD (mm)		d1 x d2 x h (mm)	C	
LMFC6UU	LMKC6UU	4	6	12	0	35	±300	15	28	22	5	20	3.5x6x3.1	323	529	31
LMFC8UU	LMKC8UU	4	8	15	-13	45	±300	20	32	25	5	24	3.5x6x3.1	431	784	51
☆LMFC10UU	☆LMKC10UU	4	10	19	0	55	-200	24.5	40	30	6	29	4.5x7.5x4.1	588	1100	98
☆LMFC12UU	☆LMKC12UU	4	12	21	0	57	-200	25.5	42	32	6	32	4.5x7.5x4.1	813	1570	110
LMFC13UU	LMKC13UU	4	13	23	-16	61	-200	27.5	43	34	6	33	4.5x7.5x4.1	813	1570	130
LMFC16UU	LMKC16UU	5	16	28	-16	70	-200	32	48	37	6	38	4.5x7.5x4.1	1230	2350	190
☆LMFC20UU	☆LMKC20UU	5	20	32	-16	80	-200	36	54	42	8	43	5.5x9x5.1	1400	2740	260
☆LMFC25UU	☆LMKC25UU	6	25	40	0	112	-300	52	62	50	8	51	5.5x9x5.1	1560	3140	540
☆LMFC30UU	☆LMKC30UU	6	30	45	0	123	-300	56.5	74	58	10	60	6.6x11x6.1	2490	5490	680
LMFC35UU	LMKC35UU	6	35	52	0	135	-300	62.5	82	64	10	67	6.6x11x6.1	2650	6270	1020
☆LMFC40UU	☆LMKC40UU	6	40	60	0	151	-300	69	96	75	13	78	9x14x8.1	3430	8040	1570
LMFC50UU	LMKC50UU	6	50	80	0	192	-300	89.5	116	92	13	98	9x14x8.1	6080	15900	3600
LMFC60UU	LMKC60UU	6	60	90	0	209	-400	95.5	134	106	18	112	11x17x11.1	7550	20000	4500

Note : ☆ means steel retainer is available.

Part No.		Main Dimensions and Tolerance														Eccentricity	Basic Load Rating		Weight (g)
Seal Type	Ball Circuit	dr (mm)	Tolerance (μm)	D (mm)	Tolerance (μm)	L (mm)	Tolerance (μm)	I (mm)	D1 (mm)	W (mm)	H (mm)	A (mm)	F (mm)	d1 x d2 x h (mm)	C		Co	N	
LMHC6UU	4	6	12	0	35	±300	15	28	18	5	20	-	3.5x6x3.1	323	529	28			
LMHC8UU	4	8	15	-13	45	±300	20	32	21	5	24	-	3.5x6x3.1	431	784	47			
LMHC10UU	4	10	19	0	55	-200	24.5	40	25	6	29	-	4.5x7.5x4.1	588	1100	90			
LMHC12UU	4	12	21	0	58	-200	25.5	42	27	6	32	-	4.5x7.5x4.1	813	1570	102			
LMHC13UU	4	13	23	-16	61	-200	27.5	43	29	6	33	-	4.5x7.5x4.1	813	1570	123			
LMHC16UU	5	16	28	-16	70	-200	32	48	34	6	31	22	4.5x7.5x4.1	1230	2350	182			
LMHC20UU	5	20	32	-16	80	-300	36	54	38	8	36	24	5.5x9x5.1	1400	2740	247			
LMHC25UU	6	25	40	0	112	-300	52	62	46	8	40	32	5.5x9x5.1	1560	3140	525			
LMHC30UU	6	30	45	0	123	-300	56.5	74	51	10	49	35	6.6x11x6.1	2490	5490	645			

4 Slide Unit 4-1 SC Series



SC_S

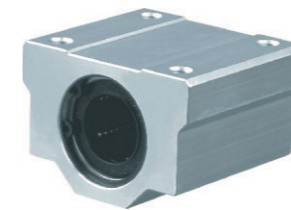
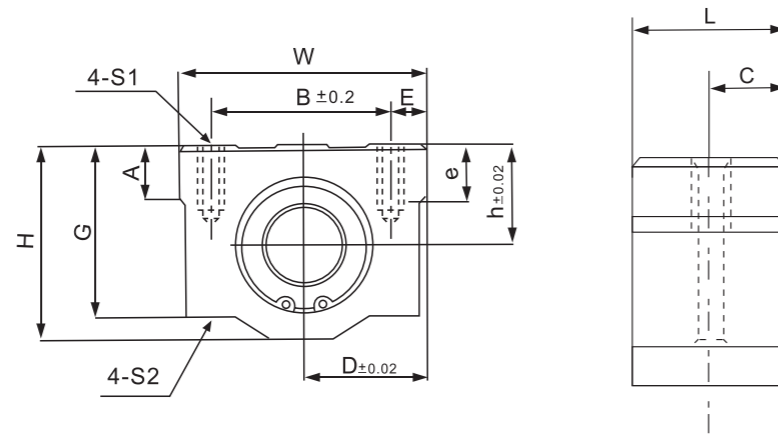

SC

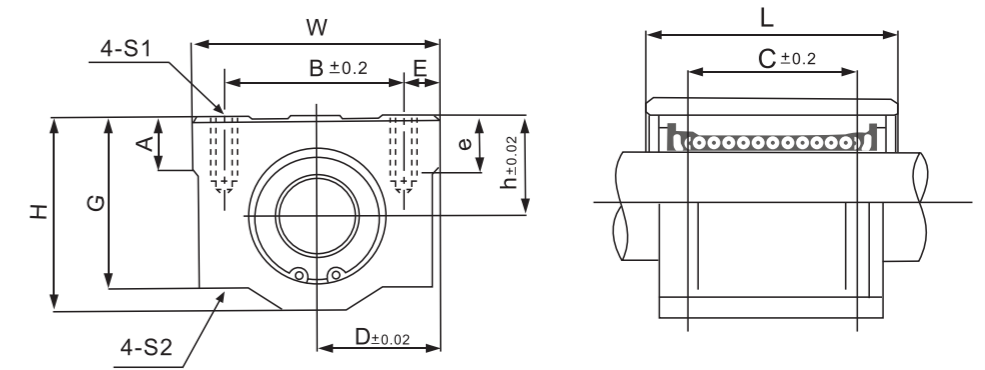

Part No.	Main Dimensions (mm)												Basic Load Rating		Weight (g)
	h	D	W	H	G	A	B	E	S1xe	S2	C	L	C N	Co N	
SC8SUU	11	17	34	22	18	6	24	5	M4X8	3.4	7.7	15.4	274	392	27
SC10SUU	13	20	40	26	21	8	28	6	M5X12	4.3	9.95	19.9	372	549	53
SC12SUU	15	21	42	28	24	8	30.5	5.75	M5X12	4.3	10.45	20.9	510	784	60
SC13SUU	15	22	44	30	24.5	8	33	5.5	M5X12	4.3	10.45	20.9	510	784	64
SC16SUU	19	25	50	38.5	32.5	9	36	7	M5X12	4.3	12	24	774	1180	110
SC20SUU	21	27	54	41	35	11	40	7	M6X12	5.2	14	28	882	1370	144
SC25SUU	26	38	76	51.5	42	12	54	11	M8X18	7	18.9	37.8	980	1570	340
SC30SUU	30	39	78	59.5	49	15	58	10	M8X18	7	20.65	41.3	1574	2740	424
SC35SUU	34	45	90	68	54	18	70	10	M8X18	7	22.65	45.3	1670	3140	626
SC40SUU	40	51	102	78	62	20	80	11	M10X25	8.7	28.15	56.3	2160	4020	1000
SC50SUU	52	61	122	102	80	25	100	11	M10X25	8.7	34.4	68.8	3820	7940	2100

Part No.	Main Dimensions (mm)												Basic Load Rating		Weight (g)
	h	D	W	H	G	A	B	E	S1xe	S2	C	L	C N	Co N	
SC8UU	11	17	34	22	18	6	24	5	M4X8	3.4	18	30	274	392	52
SC10UU	13	20	40	26	21	8	28	6	M5X12	4.3	21	35	372	549	92
SC12UU	15	21	42	28	24	8	30.5	5.75	M5X12	4.3	26	36	510	784	102
SC13UU	15	22	44	30	24.5	8	33	5.5	M5X12	4.3	26	39	510	784	120
SC16UU	19	25	50	38.5	32.5	9	36	7	M5X12	4.3	34	44	774	1180	200
SC20UU	21	27	54	41	35	11	40	7	M6X12	5.2	40	50	882	1370	255
SC25UU	26	38	76	51.5	42	12	54	11	M8X18	7	50	67	980	1570	600
SC30UU	30	39	78	59.5	49	15	58	10	M8X18	7	58	72	1574	2740	735
SC35UU	34	45	90	68	54	18	70	10	M8X18	7	60	80	1670	3140	1100
SC40UU	40	51	102	78	62	20	80	11	M10X25	8.7	60	90	2160	4020	1590
SC50UU	52	61	122	102	80	25	100	11	M10X25	8.7	80	110	3820	7940	3340

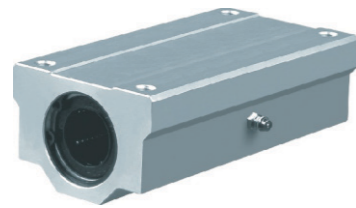

SC_L

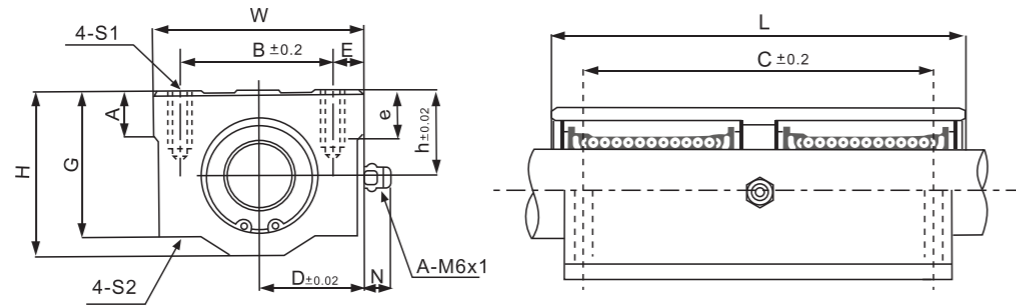

4-2 TBR Series

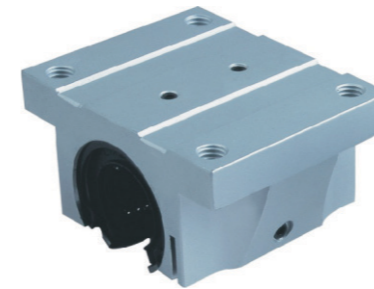

TBR

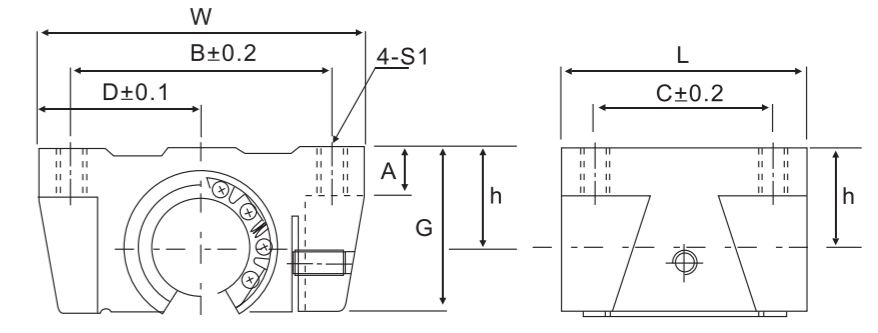

Part No.	Main Dimensions (mm)													Basic Load Rating		Weight (g)
	h	D	W	H	G	N	A	B	E	S1xe	S2	C	L	C	Co	
SC8LUU	11	17	34	22	18	7	6	24	5	M4x8	3.4	42	58	431	784	102
SC10LUU	13	20	40	26	21	7	8	28	6	M5X12	4.3	46	68	588	1100	180
SC12LUU	15	21	42	28	24	6.5	8	30.5	5.75	M5X12	4.3	50	70	813	1570	250
SC13LUU	15	22	44	30	24.5	6.5	8	33	5.5	M5X12	4.3	50	75	813	1570	240
SC16LUU	19	25	50	38.5	32.5	6	9	36	7	M5X12	4.3	60	85	1230	2350	400
SC20LUU	21	27	54	41	35	7	11	40	7	M6X12	5.2	70	96	1410	2740	570
SC25LUU	26	38	76	51.5	42	4	12	54	11	M8X18	7	100	130	1610	3140	1200
SC30LUU	30	39	78	59.5	49	5	15	58	10	M8X18	7	110	140	2450	5490	1480
SC35LUU	34	45	90	68	54	5.5	18	70	10	M8X18	7	120	155	2650	6270	2200
SC40LUU	40	51	102	78	62	5	20	80	11	M10X25	8.7	140	175	3430	8040	3200
SC50LUU	52	61	122	102	80	5	25	100	11	M10X25	8.7	160	215	6080	15900	6700

Part No.	Main Dimensions (mm)										Basic Load Rating		Weight (g)
	W	G	A	L	B	D	C	h	S1	C	Co		
TBR16UU	62	26	8	42	50	31	30	18	M5	392	490	180	
TBR20UU	68	31	10	51	54	34	37	21	M6	784	1176	300	
TBR25UU	82	41	12	65	65	41	50	28	M8	1568	2352	600	
TBR30UU	91	48	12	75	75	45.5	60	33.5	M8	1764	2940	900	

4-3 SME Series

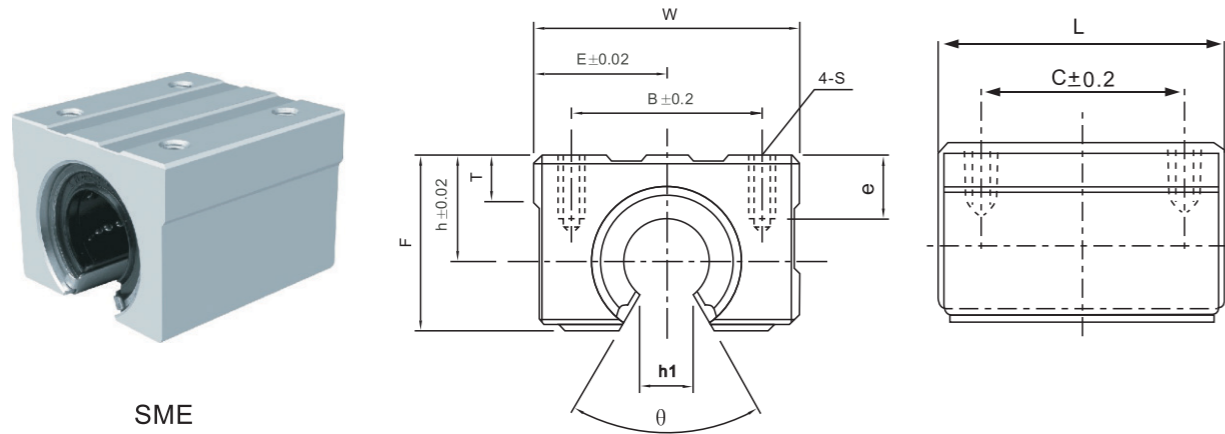

SME

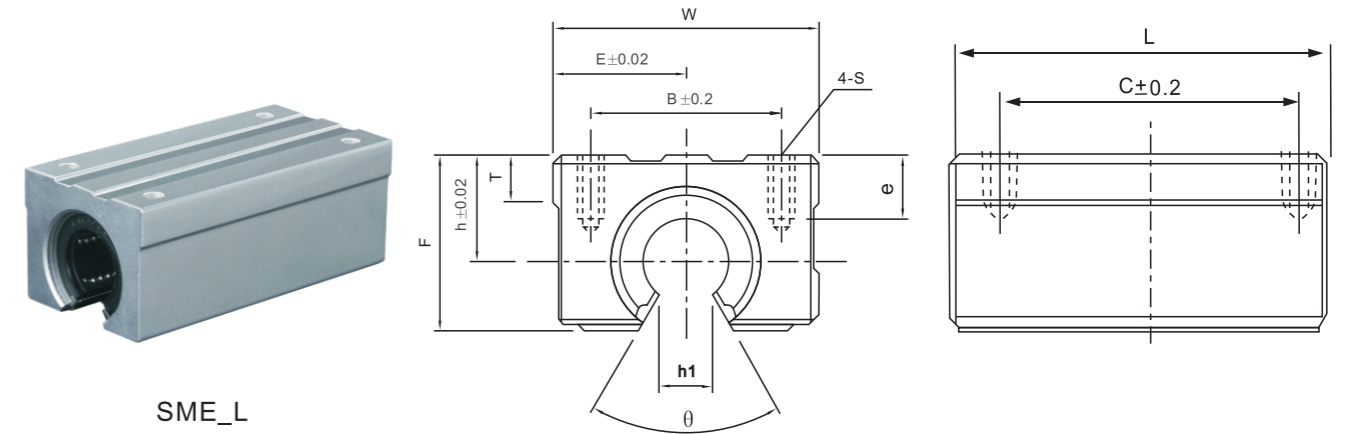

SME_L

Part No.	Main Dimensions (mm)											Slide Bush	Basic Load Rating		Weight (g)
	h	D	W	L	F	T	h1	θ	B	C	Sxe		C N	Co N	
SME16UU	20	22.5	45	45	33	9	10	80°	32	30	M5x12	LM16UU-OP	774	1180	150
SME20UU	23	24	48	50	39	11	10	60°	35	35	M6x12	LM20UU-OP	882	1370	200
SME25UU	27	30	60	65	47	14	11.5	50°	40	40	M6x12	LM25UU-OP	980	1570	450
SME30UU	33	35	70	70	56	15	14	50°	50	50	M8x18	LM30UU-OP	1570	2740	630
SME35UU	37	40	80	80	63	18	16	50°	55	55	M8x18	LM35UU-OP	1670	3140	925
SME40UU	42	45	90	90	72	20	19	50°	65	65	M10x20	LM40UU-OP	2160	4020	1330
SME50UU	53	60	120	110	92	25	23	50°	94	80	M10x20	LM50UU-OP	3820	7940	3000

Part No.	Main Dimensions (mm)											Slide Bush	Basic Load Rating		Weight (g)
	h	D	W	L	F	T	h1	θ	B	C	Sxe		C N	Co N	
SME16LUU	20	22.5	45	85	33	9	10	80°	32	60	M5x12	LM16UU-OPx2	1230	2350	300
SME20LUU	23	24	48	95	39	11	10	60°	35	70	M6x12	LM20UU-OPx2	1400	2740	400
SME25LUU	27	30	60	130	47	14	11.5	50°	40	90	M6x12	LM25UU-OPx2	1560	3140	900
SME30LUU	33	35	70	140	56	15	14	50°	50	100	M8x18	LM30UU-OPx2	2490	5490	1260

4-4 KBA Series



KBA_S

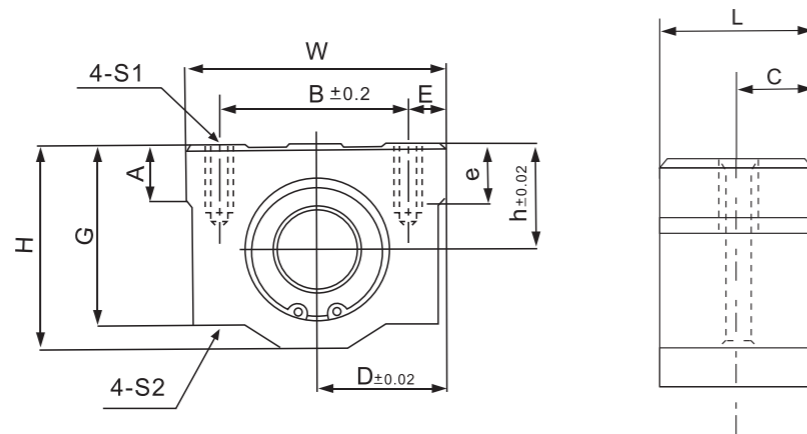

KBA

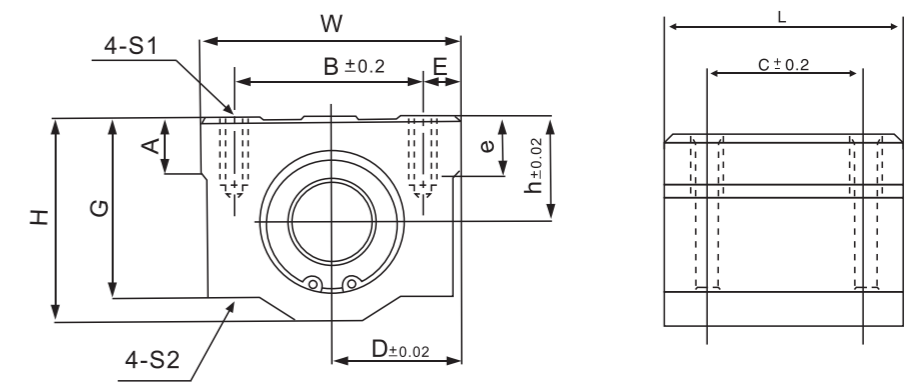

Part No.	Main Dimensions (mm)												Basic Load Rating		Weight (g)
	h	D	W	H	G	A	B	E	S1xe	S2	C	L	C N	Co N	
KBA8SUU	11	17	34	22	18	6	24	5	M4X8	3.4	7.2	14.4	274	392	25
KBA12SUU	15	22	44	30	24.5	8	33	5.5	M5X12	4.3	10.4	20.8	510	784	65
KBA16SUU	19	25	50	38.5	32.5	9	36	7	M5X12	4.3	11.2	22.4	774	1180	100
KBA20SUU	21	27	54	41	35	11	40	7	M6X12	5.2	14.5	29	882	1370	148
KBA25SUU	26	38	76	51.5	42	12	54	11	M8X18	7	20.45	40.9	980	1570	368
KBA30SUU	30	39	78	59.5	49	15	58	10	M8X18	7	24.45	48.9	1574	2740	500
KBA40SUU	40	51	102	78	62	20	80	11	M10X25	8.7	28.2	56.4	2160	4020	1000
KBA50SUU	52	61	122	102	80	25	100	11	M10X25	8.7	36.2	72.4	3820	7940	2205

Part No.	Seal Type	Shaft Diameter	Main Dimensions (mm)											Weight (g)	
			h	D	W	L	H	G	T	B	C	E	S1xe		S2
KBA10UU		10	13	20	40	35	26	21	8	28	21	6	M5x12	4.3	92
KBA12UU		12	15	22	44	39	30	24.5	8	33	26	5.5	M5x12	4.3	120
KBA16UU		16	19	25	50	44	38.5	32.5	9	36	34	7	M5x12	4.3	200
KBA20UU		20	21	27	54	53	41	35	11	40	40	7	M6x12	5.2	270
KBA25UU		25	26	38	76	67	51.5	42	12	54	50	11	M8x18	7	600
KBA30UU		30	30	39	78	76	59.5	49	15	58	58	10	M8x18	7	776
KBA40UU		40	40	51	102	90	78	62	20	80	60	11	M10x25	8.7	1590
KBA50UU		50	52	61	122	110	102	80	25	100	80	11	M10x25	8.7	3340
KBA60UU		60	58	66	132	137	114	94	30	108	90	12	M12x25	10.7	4800

Linear Bushing - KBA_L Series



Linear Bushing - KBE Series

Linear Guideways

Ball Screw

Support

Linear Bushing

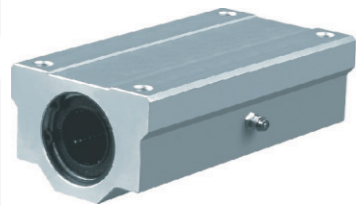

KBA_L

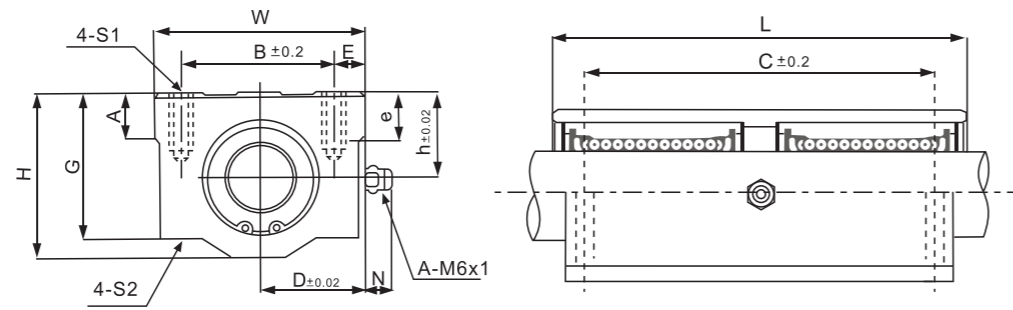

4-5 KBE Series

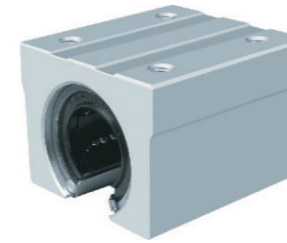

KBE

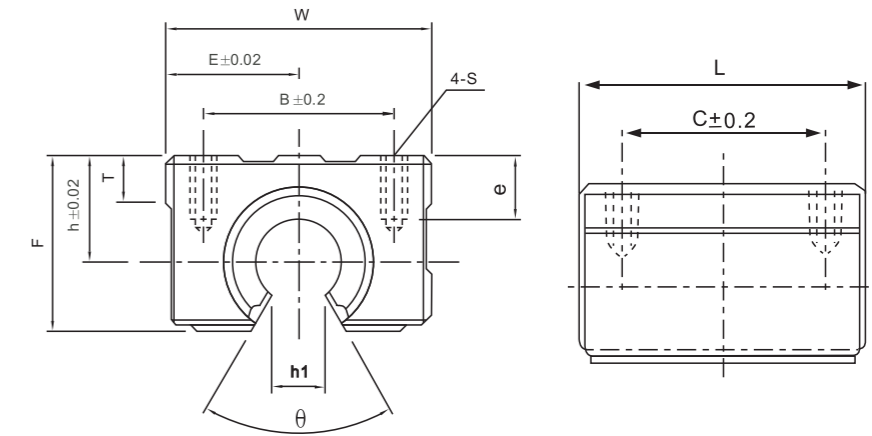

Part No.		Main Dimensions (mm)											Weight (g)	
Seal Type	Shaft Diameter	h	D	W	L	H	G	T	B	C	E	S1xe		S2
KBA10LUU	10	13	20	40	68	26	21	8	28	46	6	M5x12	4.3	180
KBA12LUU	12	15	22	44	77	30	24.5	8	33	64	5.5	M5x12	4.3	237
KBA16LUU	16	19	25	50	89	38.5	32.5	9	36	79	7	M5x12	4.3	405
KBA20LUU	20	21	27	54	100	41	35	11	40	90	7	M6x12	5.2	510
KBA25LUU	25	26	38	76	136	51.5	42	12	54	119	11	M8x18	7	1220
KBA30LUU	30	30	39	78	154	59.5	49	15	58	132	10	M8x18	7	1580
KBA40LUU	40	40	51	102	180	78	62	20	80	150	11	M10x25	8.7	3180
KBA50LUU	50	52	61	122	230	102	80	25	100	200	11	M10x25	8.7	6990

Part No.		Main Dimensions (mm)											Basic Load Rating		Weight (g)
Seal Type	Shaft Diameter	h	D	W	L	H	T	h1	θ	B	C	Sxe	C N	Co N	
KBE16UU	16	20	22.5	45	45	33	9	10	80°	32	30	M5x12	774	1180	150
KBE20UU	20	23	24	48	50	39	11	10	60°	35	35	M6x12	882	1370	200
KBE25UU	25	27	30	60	65	47	14	11.5	60°	40	40	M6x12	980	1570	450
KBE30UU	30	33	35	70	70	56	15	14	60°	50	50	M8x18	1570	2740	630
KBE40UU	40	42	45	90	90	72	20	19	60°	65	65	M10x20	2160	4020	1330
KBE50UU	50	53	60	120	110	92	25	23	60°	94	80	M10x20	3820	7940	3000

Linear Guideways

Ball Screw

Support

Linear Bushing

5 Shaft Support 5-1 SK Series

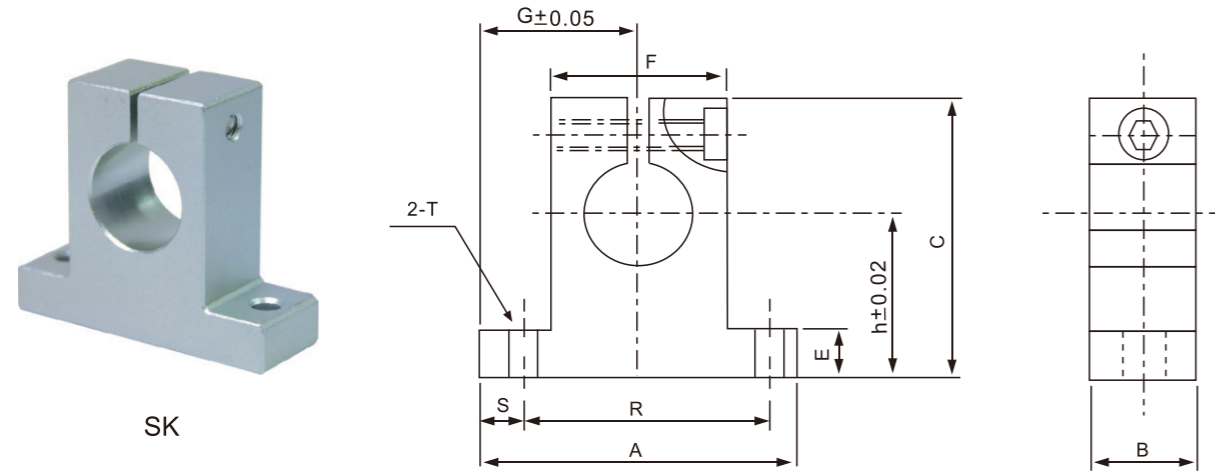

5-2 SHF Series

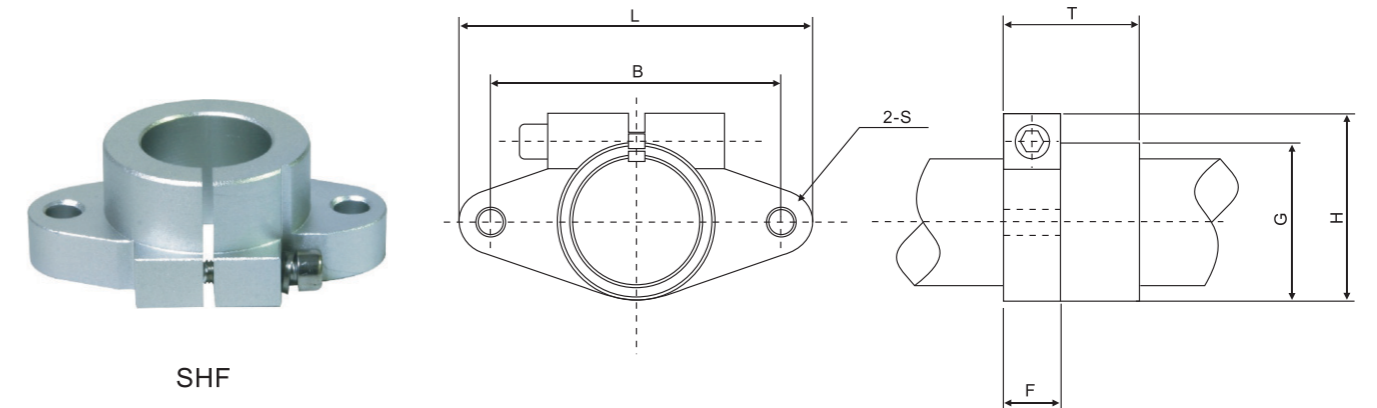

Part No.	Shaft diameter	Main Dimensions (mm)										Clamping bolt designation	Mounting bolt designation	Weight (g)
		h	G	A	B	C	E	F	R	S	T			
SK-8	8	20	21	42	14	32.8	6	18	32	5	5.5	M4	M5	24
SK-10	10	20	21	42	14	32.8	6	18	32	5	5.5	M4	M5	24
SK-12	12	23	21	42	14	37.5	6	20	32	5	5.5	M4	M5	30
SK-13	13	23	21	42	14	37.5	6	20	32	5	5.5	M4	M5	30
SK-16	16	27	24	48	16	44	8	25	38	5	5.5	M4	M5	40
SK-20	20	31	30	60	20	51	10	30	45	7.5	6.6	M5	M6	70
SK-25	25	35	35	70	24	60	12	38	56	7	6.6	M6	M6	130
SK-30	30	42	42	84	28	70	12	44	64	10	9	M6	M8	180
SK-35	35	50	49	98	32	82	15	50	74	12	11	M8	M10	270
SK-40	40	60	57	114	36	96	15	60	90	12	11	M8	M10	420
SK-50	50	70	63	126	40	120	18	74	100	13	14	M12	M12	750

Part No.	Shaft diameter	Main Dimensions (mm)							Clamping bolt designation	Mounting bolt designation	Weight (g)
		L	T	F	B	G	H	S			
SHF-10	10	43	10	5	32	20	24	5.5	M5	M4	13
SHF-12	12	47	13	7	36	25	28	5.5	M5	M4	20
SHF-13	13	47	13	7	36	25	28	5.5	M5	M4	20
SHF-16	16	50	16	8	40	28	31	5.5	M5	M4	27
SHF-20	20	60	20	8	48	34	37	7	M6	M5	40
SHF-25	25	70	25	10	56	40	42	7	M6	M5	60
SHF-30	30	80	30	12	64	46	50	9	M8	M6	110
SHF-35	35	92	35	14	72	50	58	12	M10	M8	380
SHF-40	40	105	40	16	80	56	67	12	M10	M10	510
SHF-50	50	122	50	19	96	70	83	14	M12	M12	890